



# Rear Step Bar

Part No. FBV01B



Fits: 2014- Current Dodge Ram ProMaster



REMOVE CONTENTS FROM BOX. VERIFY ALL PARTS ARE PRESENT.



60-180 min



CUTTING NOT REQUIRED



DRILLING NOT REQUIRED



READ INSTRUCTIONS CAREFULLY BEFORE STARTING INSTALLATION.

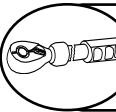

DO NOT OVER TORQUE. STANDARD OPERATING LOAD FOR TIGHTEN BODY MOUNT NUTS & BOLTS VARIES FROM 45 TO 65 FOOT POUND.

### PARTS LIST:

Qty	Part Description	Qty	Part Description
1	Rear Step	2	12mm Lock Washers
1	Driver/left Frame Mounting Bracket	2	12mm Hex Nuts
1	Passenger/right Frame Mounting Bracket	2	6mm Double Bolt Plates
2	12mm Bolt Plates	4	6mm x 22mm x 2mm Flat Washers
2	12mm Plastic Retainers	4	6mm Lock Washers
2	12mm x 32mm x 3mm Flat Washers	4	6mm Hex Nuts

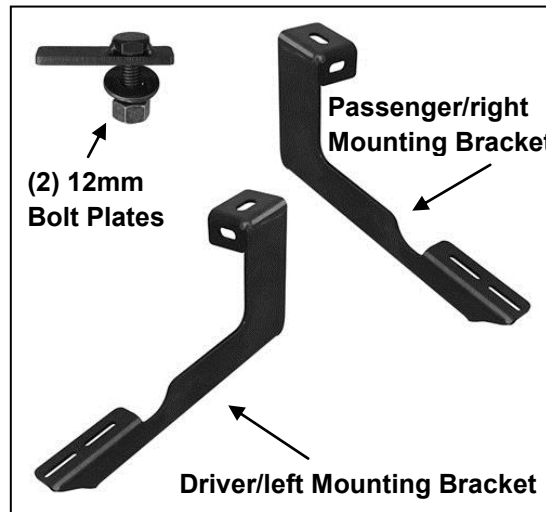

### PROCEDURE:

INSTALLATION MAY INTERFERE WITH FACTORY OR AFTERMARKET TOW HITCH AND/OR

BACKUP  
SENSOR

**WARNING: ALLOW TIME FOR THE MUFFLER TO COOL COMPLETELY BEFORE INSTALLING REAR BUMPER GUARD BRACKETS.**

OPERATION.

1. Starting on the passenger side of the vehicle, locate the square hole in end of the rear frame channel, **(Figure 1)**. **NOTE:** Remove rubber plug if equipped. Next, remove the factory hex nut attaching the bottom bumper bracket bolt to the frame channel inside the rear tow hook.
2. Insert (1) 12mm Bolt Plate into the square hole in the bottom of the frame channel, **(Figures 1 & 2)**. Use the included 12mm Plastic Retainer to help hold the Bolt Plate in place in the frame.

Remove factory hex nut and rubber plug



**Fig 1**

Remove excess sealant as necessary to clear bracket for proper fitment



**(Fig 2) 12mm Bolt Plate**

3. Select the passenger/right side Frame Mounting Bracket. Attach the Bracket to the Bolt Plate with the included 12mm Flat Washer, 12mm Lock Washer and 12mm Hex Nut, **(Figure 3)**. Reuse the factory hex nut to attach the mounting tab on the Bracket to the bumper bracket bolt. Do not fully tighten hardware at this time.

Reuse factory bumper bolt hardware

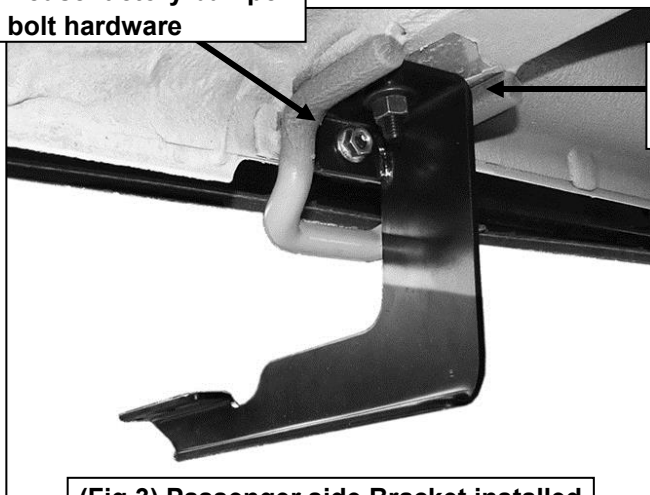

12mm Flat Washer  
12mm Lock Washer  
12mm Hex Nut

**(Fig 3) Passenger side Bracket installed**

4. Repeat **Steps 1—3** to install the driver side Bracket.
5. Select the Rear Step. Place the Step on top of the Brackets. Select (2) 6mm Double Bolt Plates, **(Figure 4)**. Insert the Bolt Plates up and into the channels in the bottom of the Step closest to the location of the Brackets, **(Figure 4)**. Raise the Step up and slide the Bolt Plates down through the slots in the Brackets.

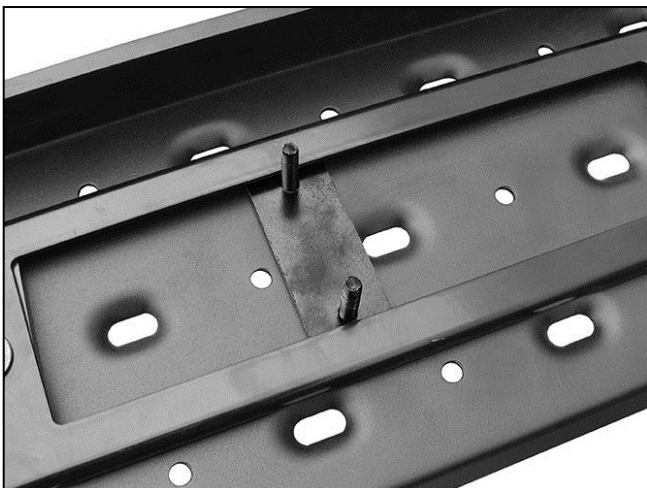

**(Fig 4) Slide Double Bolt Plates into track on bottom of Step**

6. Attach the Step to the Brackets with (4) 6mm Flat Washers, (4) 6mm Lock Washers and (4) 6mm Hex Nuts, (**Figure 5**). Do not fully tighten hardware at this time.

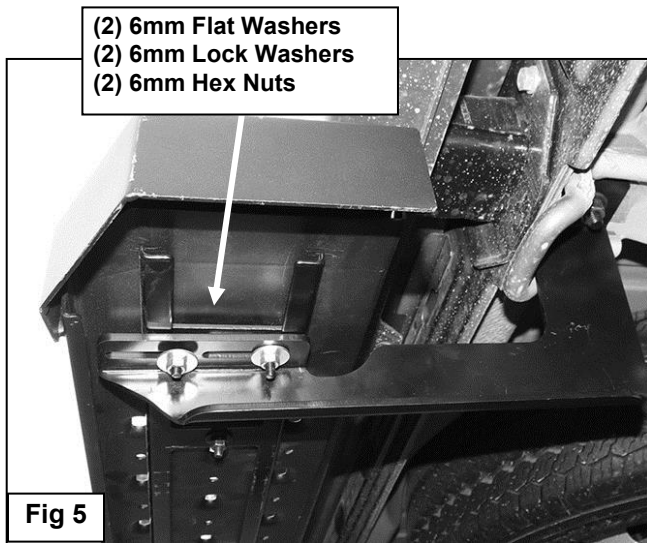

7. Align and adjust the Rear Step as necessary and fully tighten all hardware.
8. Do periodic inspections of the installation to make sure that all hardware is secure and tight.



## PARTS IDENTIFICATION GUIDE

**Driver Side tube packed using "Green" color foam sheet. Passenger Side tube packed using "White" color foam sheet**

No.	Parts Identification
1	Passenger / Right 'Rear' Bracket marked "PR"
2	Driver / Left 'Rear' Bracket marked "DR"
3	Passenger / Right 'Center' Bracket marked "PC"
4	Driver / Left 'Center' Bracket marked "DC"
5	Passenger / Right 'Front' Bracket marked "PF"
6	Driver / Left 'Front' Bracket marked "DF"

### Note:

- This guide is to identify the parts and not a reference for part count.
- For part count, refer Parts List.
- Product / Bracket image is representative and actual design may vary.

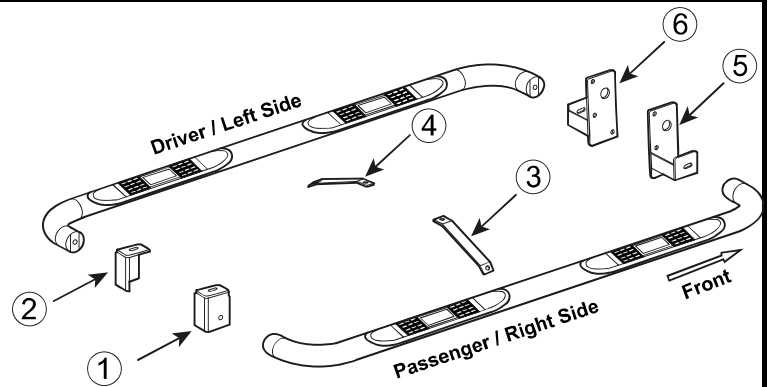

## PRODUCT CARE

- Periodically check the product to ensure all fasteners are tight and components are intact.
- Regular waxing is recommended to protect the finish of the product.
- **Use ONLY Non-Abrasive automotive wax.** Use of any soap, polish or wax that contains an abrasive is detrimental and can scratch the finish leading to corrosion.
- Aluminum polish may be used to polish small scratches and scuffs for **Stainless Steel finish.**
- Mild soap may be used to clean the product for both **Stainless Steel and Black finish.**

### 1. Hardware's are not of correct size.

*In GMC / Chevrolet truck model 2006 & up, customer needs to reuse the factory body bolts to install the bracket. If your vehicle is not GMC / Chevrolet 2006 & up, ensure that holes are not partially covered with any plastic grommet or rust? If it is, remove the plastic grommet & rust from the thread holes & re-try the installation.*

### 2. Mounting Bracket are not getting Installed properly.

*In some cases Illustration images shown in Installation manual may not be the exactly same as per actual vehicle images ,also if Driver / Passenger side mounting brackets are very identical in the design, suggest referring Parts Identification guide to avoid fitment issue.*

### 3. Products are thumping / rattling after installation.

*Ensure that all required mounting brackets / hardware's are installed & tighten correctly. Suggest using white lithium / regular grease between the metal to metal contact surfaces.*

### 4. Side Bar is not aligning with vehicle / Step Pads are not aligning with vehicle doors.

*Side bar may be interchanged or mounting brackets are not installed at the correct position in the vehicle. Refer Parts identification guide.*

### 5. Missing / Excess Hardware.

*Recheck hardware count as per the part list.*

### 6. Product not installing properly.

*Ensure make model year, cab length and bed size of your vehicle is listed in the application. All installation steps are followed correctly.*