

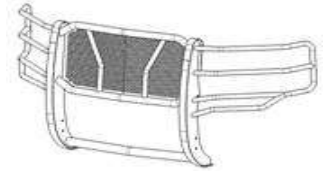

Extreme Grille Guard

Part No. E0513B



Fits: Current Silverado 1500
Excl. Diesel Models With Def Tanks & 2019 Silverado 1500 LD



REMOVE CONTENTS FROM BOX. VERIFY ALL PARTS ARE PRESENT.

60-180 min

CUTTING May Be
REQUIRED

DRILLING NOT
REQUIRED



READ INSTRUCTIONS CAREFULLY BEFORE STARTING INSTALLATION.

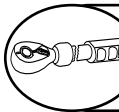

DO NOT OVER TORQUE. STANDARD OPERATING LOAD FOR TIGHTEN
BODY MOUNT NUTS & BOLTS VARIES FROM 45 TO 65 FOOT POUND.

PARTS LIST:

Qty	Part Description	Qty	Part Description
1	Extreme Grille Guard Assembly	14	12mm x 32mm x 3mm Flat Washers
1	Driver/Left GG Mounting Bracket	10	12mm Lock Washers
1	Passenger/Right GG Mounting Bracket	10	12-1.75mm Hex Nuts
1	Driver/Left Top Bracket	2	10-1.50mm x 30mm Hex Bolts
1	Passenger/Right Top Bracket	4	10mm x 27mm OD x 3mm Flat Washers
2	12-1.75mm x 30mm Double Bolt Plates	2	10mm Nylon Lock Nuts
2	12-1.75mm x 35mm Single Bolt Plates	1	Wrench
4	12-1.75mm x 35mm Hex Bolts	2	Adhesive Backed Foam Tapes

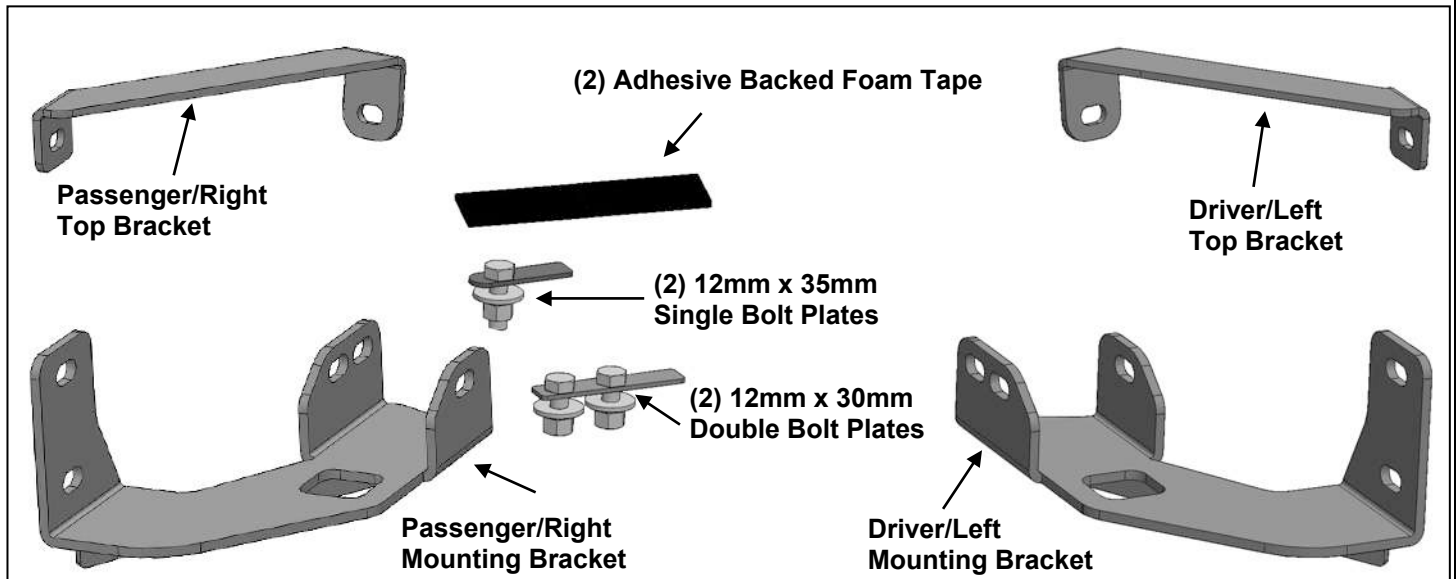

PROCEDURE:

REMOVE CONTENTS FROM BOX AND VERIFY ALL PARTS ARE PRESENT. READ INSTRUCTIONS CAREFULLY. CUTTING MAY BE REQUIRED. ASSISTANCE IS HIGHLY RECOMMENDED. INSTALLATION MAY INTERFERE WITH FRONT MOUNTED SENSORS.

1. Remove the factory tow hook hardware only if equipped, (Figures 1 & 2). Leave the tow hooks in the frame.
2. Cut out the indented area in both sides of the plastic bumper insert to clear the Brackets as pictured, (Figure 3 & 4). **NOTE:** Models with tow hooks will only require minor trimming to the bottom of the

opening. **IMPORTANT:** Make several small cuts for best fit. Do not cut through the top or bottom edge of the panel.

3. Select the driver side Frame Mounting Bracket, (**Figure 6**). Insert the Frame Bracket through the opening in the bumper. Line up the holes in the Frame Bracket with the holes in the frame for the tow hook.

Models with tow hooks:

- a. Reuse the factory hardware to attach the Bracket to the bottom of the frame.

Models without tow hooks:

- a. Select (1) 12mm Single Bolt Plate, (**Figures 6 & 7**). Insert the Bolt Plate into the end of the frame, through the hole in the side of the frame and out through the Frame Bracket, Attach the Frame Bracket to the Bolt Plate with (1) 12mm Flat Washer, (1) 12mm Lock Washer and (1) 12mm Hex Nut, (**Figure 8**). Snug but do not tighten at this time.
 - b. Select (1) 12mm Double Bolt Plate, (**Figures 6 & 9**). Attach the Frame Bracket to the Bolt Plate with (2) 12mm Flat Washers, (2) 12mm Lock Washers and (2) 12mm Hex Nuts, (**Figure 10**). Snug but do not fully tighten hardware at this time.
4. Repeat **Steps 2 & 3** to install the passenger/right Frame Mounting Bracket.
 5. Open the hood and remove the cover between the top of the radiator and the grille, (**Figure 11**).
 6. Carefully remove the grille from the vehicle. **NOTE:** Grille is held in place with screws at the top and several clips. Remove the screws and firmly pull the grille straight out from the vehicle to release the grille from clips, (**Figure 12**).
 7. Move up to the top of the bumper. Select the Driver/left Top Bracket. Apply a layer of the included Adhesive Backed Foam Tame to the bottom of the Bracket, (**Figure 13**). Trim Foam for best fit.
 8. Locate the (2) factory hex bolts attaching the top of the bumper to the inner bumper bracket. Remove the outer hex bolt, (**Figure 14**). Reuse the factory hex bolt to attach the Top Bracket to the back of the bumper, (**Figure 15**). Do not tighten hardware at this time.
 9. Repeat **Steps 7 & 8** to install the passenger/right Top Bracket, (**Figure 16**).
 10. With assistance, hold the Grille Guard up in position on the outside of the Mounting Brackets, (**Figures 16 & 17**). Attach the Grille Guard to the Frame Brackets with (4) 12mm Hex Bolts, (8) 12mm Flat Washers, (4) 12mm Lock Washers and (4) 12mm Hex Nuts, (**Figures 17 & 18**). Do not tighten hardware at this time.
 11. Attach the Top Brackets to the Grille Guard with the included (2) 10mm Hex Bolts, (4) 10mm Flat Washers and (2) 10mm Nylon Lock Nuts, (**Figure 19**). Check the Grille guard alignment with the vehicle. Adjust as required then fully tighten the Top and Frame Bracket to vehicle hardware only. Do not fully tighten the Grille Guard to Bracket hardware at this time.
 12. Reinstall the grille and top cover. **NOTE:** Loosen the hardware attaching the Grille Guard to the Brackets and tilt the Grille Guard forward to make room to reinstall the grille. **IMPORTANT:** Top Bracket to back of bumper hardware must be fully tightened before reinstalling the grille.
 13. Level and adjust the Grille Guard and fully tighten all hardware.
 14. On models with grille mounted front camera, remove the center panel from the Grille Guard, (**Figure 20**)..
 15. Do periodic inspections to the installation to make sure that all hardware is secure and tight.

Driver Side Mounting Bracket Installation Pictured

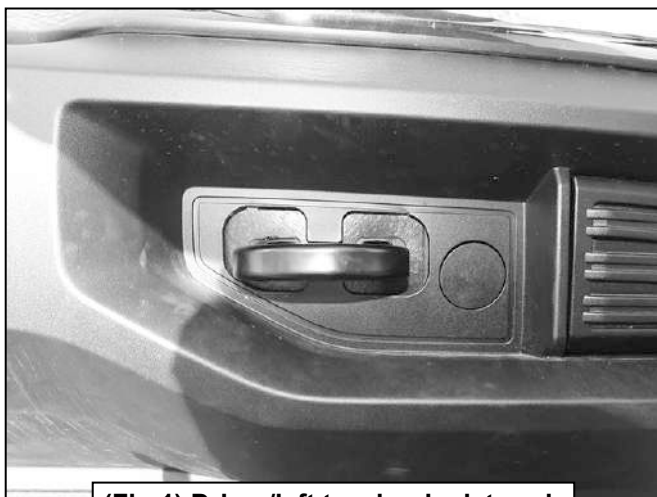

(Fig 1) Driver/left tow hook pictured

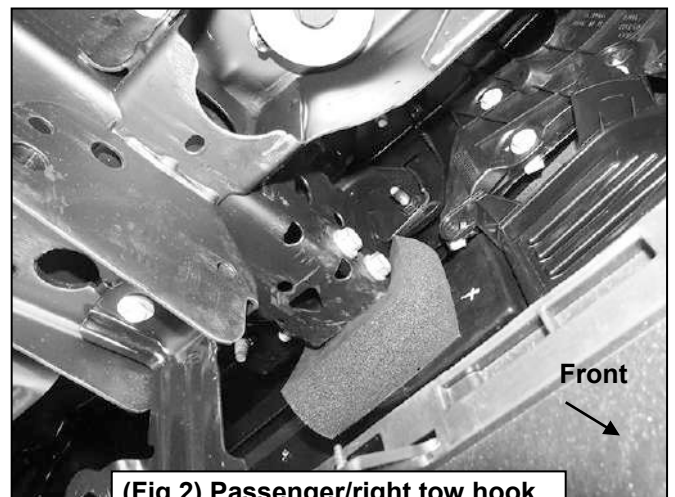

(Fig 2) Passenger/right tow hook pictured from behind bumper

Driver Side Mounting Bracket Installation Pictured



(Fig 3) Tow hook removed. Opening may need to be trimmed to clear the Mounting Bracket assembly

Area to cut out illustrated for example only

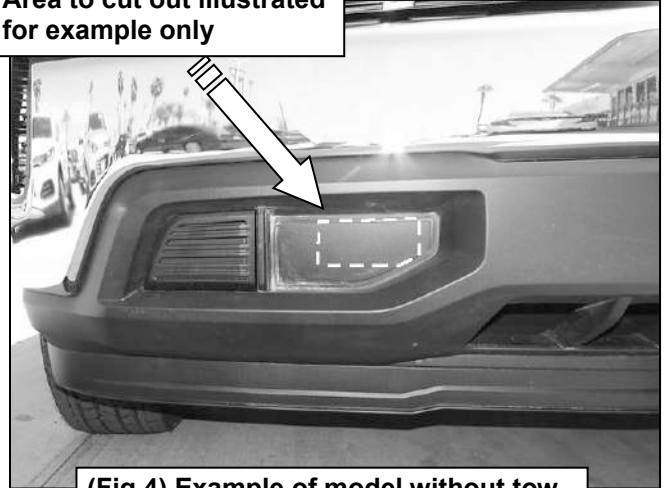

(Fig 4) Example of model without tow hooks, passenger/right side pictured

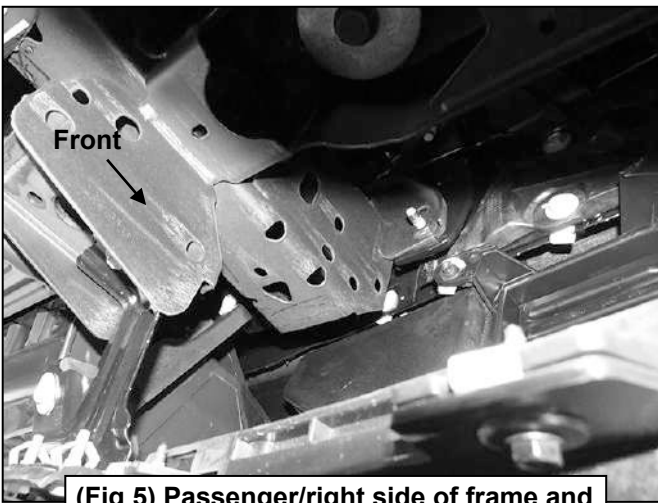

(Fig 5) Passenger/right side of frame and bumper pictured from behind bumper

12mm Double Bolt Plate
(2) 12mm Flat Washers
(2) 12mm Lock Washers
(2) 12mm Hex Nuts

12mm Bolt Plate
12mm Flat Washer
12mm Lock Washer
12mm Hex Nut

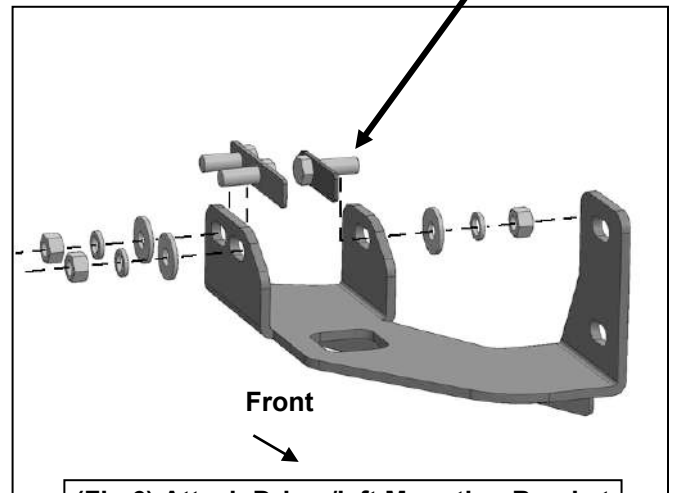

(Fig 6) Attach Driver/left Mounting Bracket to end of frame with Bolt Plates

Driver Side Mounting Bracket Installation Pictured

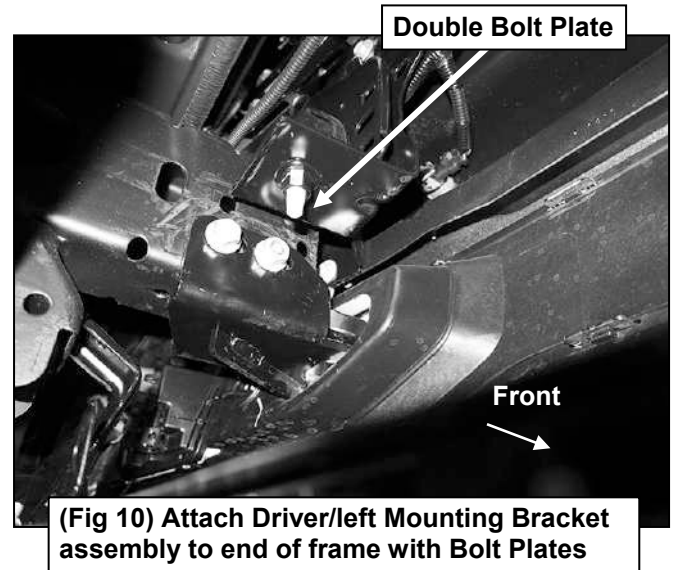
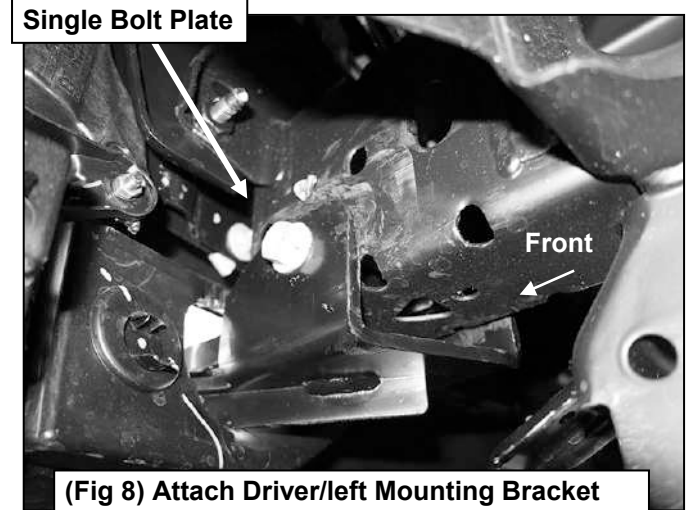
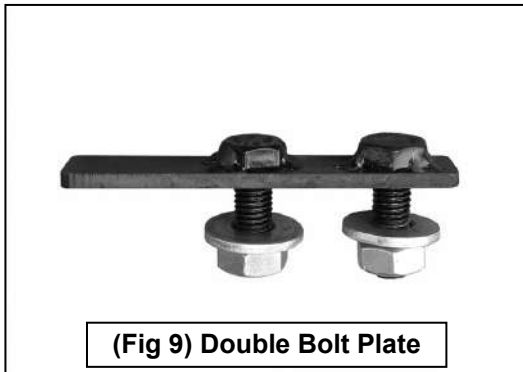

Driver Side Mounting Bracket Installation Pictured



(Fig 12) Remove screws attaching grille and carefully pull grille straight out to remove grille

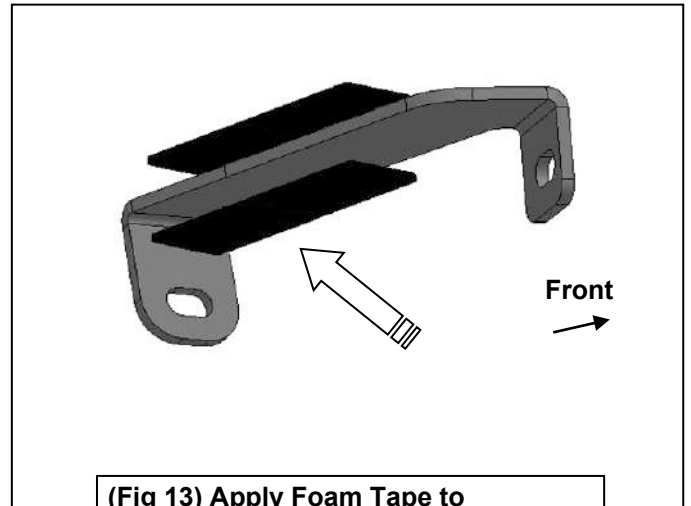

(Fig 13) Apply Foam Tape to underside of Driver/left Top Bracket

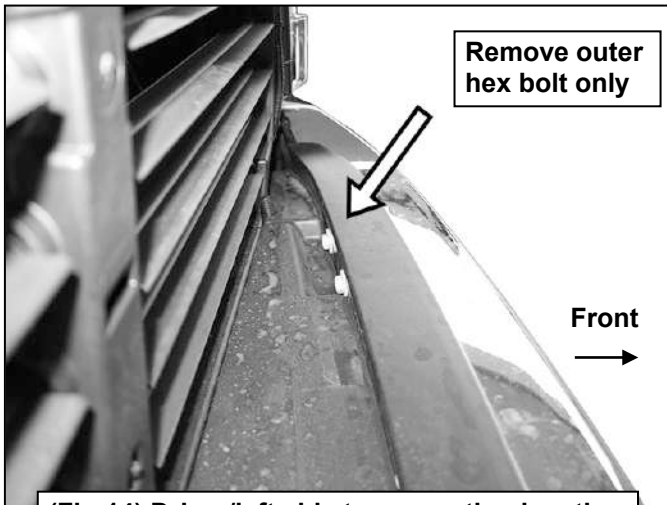

(Fig 14) Driver/left side top mounting location

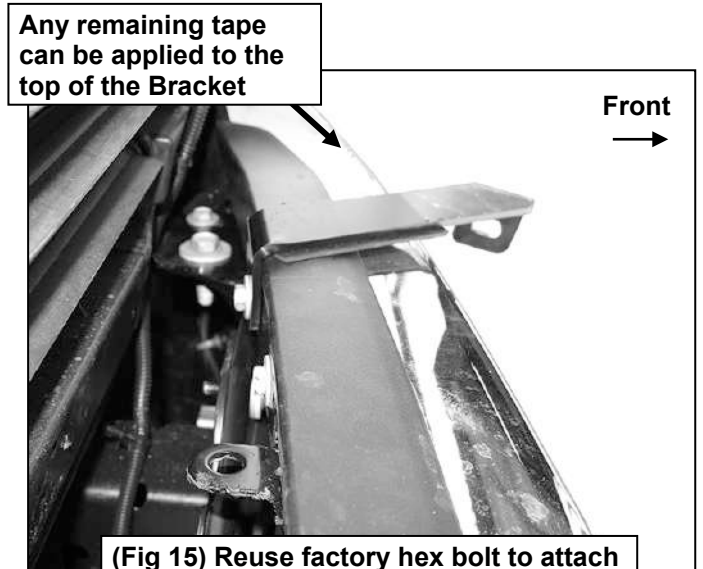

(Fig 15) Reuse factory hex bolt to attach Top Bracket to back of bumper



(Fig 16) All Mounting Brackets installed

Driver Side Mounting Bracket Installation Pictured

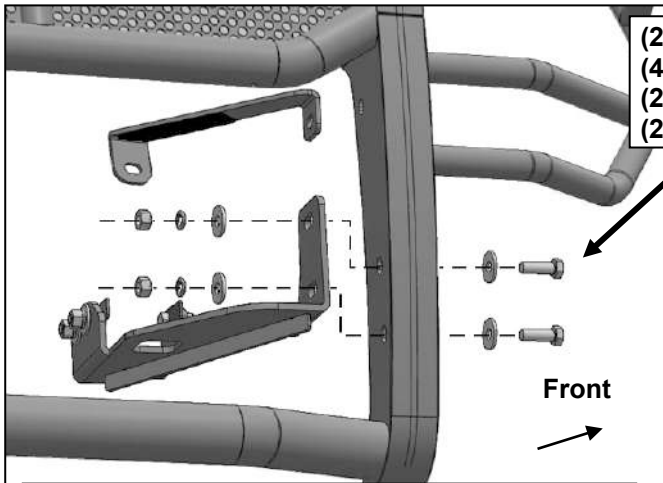

- (2) 12mm x 35mm Hex Bolts
- (4) 12mm Flat Washers
- (2) 12mm Lock Washers
- (2) 12mm Hex Nuts

Mounting holes for optional parking sensor relocation kit (available separately)

(Fig 17) Attach Grille Guard to Frame Brackets

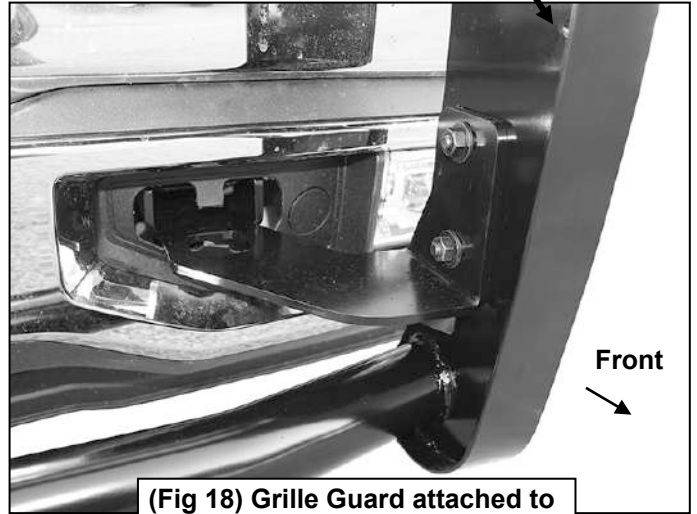

(Fig 18) Grille Guard attached to driver/left Frame Bracket

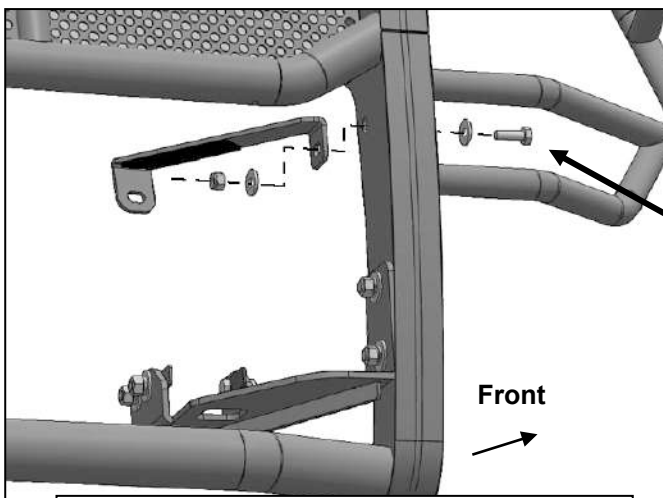

- 10mm x 30mm Hex Bolt
- (2) 10mm Flat Washers
- 10mm Nylon Lock Nut

(Fig 19) Attach Grille Guard to Top Bracket

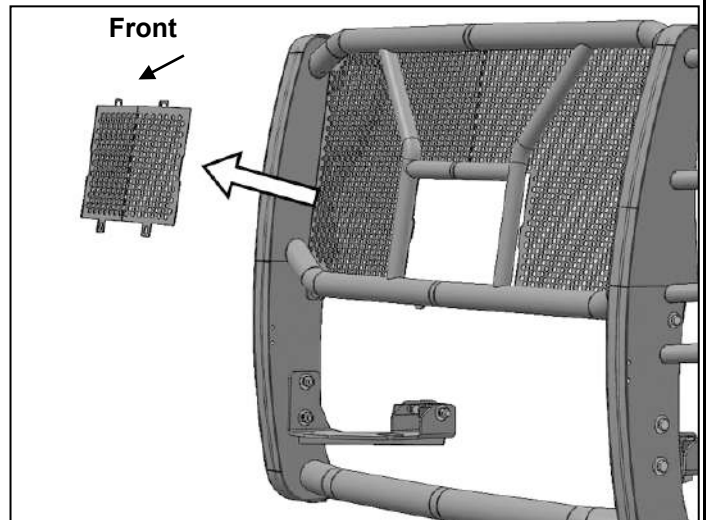

(Fig 20) On models equipped with grille mounted camera, remove center grille panel



Complete Installation

1	Passenger / Right 'Rear' Bracket marked "PR"	
2	Driver / Left 'Rear' Bracket marked "DR"	
3	Passenger / Right 'Center' Bracket marked "PC"	
4	Driver / Left 'Center' Bracket marked "DC"	
5	Passenger / Right 'Front' Bracket marked "PF"	
6	Driver / Left 'Front' Bracket marked "DF"	

Note:

- This guide is to identify the parts and not a reference for part count.
- For part count, refer Parts List.
- Product / Bracket image is representative and actual design may vary.

PRODUCT CARE

- Periodically check the product to ensure all fasteners are tight and components are intact.
- Regular waxing is recommended to protect the finish of the product.
- **Use ONLY Non-Abrasive automotive wax.** Use of any soap, polish or wax that contains an abrasive is detrimental and can scratch the finish leading to corrosion.
- Aluminum polish may be used to polish small scratches and scuffs for **Stainless Steel finish.**
- Mild soap may be used to clean the product for both **Stainless Steel and Black finish.**

FAQ's

1. **Hardware's are not of correct size.**
In GMC / Chevrolet truck model 2006 & up, customer needs to reuse the factory body bolts to install the bracket. If your vehicle is not GMC / Chevrolet 2006 & up, ensure that holes are not partially covered with any plastic grommet or rust? If it is, remove the plastic grommet & rust from the thread holes & re-try the installation.
2. **Mounting Bracket are not getting Installed properly.**
In some cases Illustration images shown in Installation manual may not be the exactly same as per actual vehicle images ,also if Driver / Passenger side mounting brackets are very identical in the design, suggest referring Parts Identification guide to avoid fitment issue.
3. **Products are thumping / rattling after installation.**
Ensure that all required mounting brackets / hardware's are installed & tighten correctly. Suggest using white lithium / regular grease between the metal to metal contact surfaces.
4. **Side Bar is not aligning with vehicle / Step Pads are not aligning with vehicle doors.**
Side bar may be interchanged or mounting brackets are not installed at the correct position in the vehicle. Refer Parts identification guide.
5. **Missing / Excess Hardware.**
Recheck hardware count as per the part list.
6. **Product not installing properly.**
Ensure make model year, cab length and bed size of your vehicle is listed in the application. All installation steps are followed correctly.

Check out these other TrailFX Products!!



Keystone Automotive Operations Inc. (KAO) warrants this product to be free of defects in material and workmanship at the time of purchase by the original retail consumer. KAO disclaims any other warranties, express or implied, including the warranty of fitness for a particular purpose or an intended use. If the product is found to be defective, KAO may replace or repair the product at our option, when the product is returned prepaid, with proof of purchase. Alteration to, improper installation, or misuse of this product voids the warranty. KAO's liability is limited to repair or replacement of products found to be defective, and specifically excludes liability for any incidental or consequential loss or damage.