

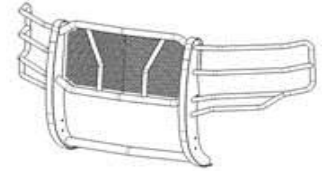

# Extreme Grille Guard

## Part No. E0511B



Fits: 2017

Ford 250 /350 /450/ 550 Super Duty



60-180 min



Cutting Required



Drilling Not Required



REMOVE CONTENTS FROM BOX. VERIFY ALL PARTS ARE PRESENT.



READ INSTRUCTIONS CAREFULLY BEFORE STARTING INSTALLATION.

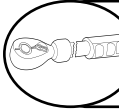

DO NOT OVER TORQUE. STANDARD OPERATING LOAD FOR TIGHTEN BODY MOUNT NUTS & BOLTS VARIES FROM 45 TO 65 FOOT POUND.

### PARTS LIST:

Qty	Part Description	Qty	Part Description
1	Grille Guard	2	12mm Plastic Retainers
1	Driver/Left Frame Mounting Bracket	8	12-1.75mm x 35mm Hex Bolts
1	Passenger/Right Frame Mounting Bracket	16	12mm x 32mm OD x 3mm Flat Washers
2	Spacer Plates	8	12mm Lock Washers
1	Driver/Left Lower Mounting Bracket	8	12mm Hex Nuts
1	Passenger/Right Lower Mounting Bracket	1	2.5mm Wrench

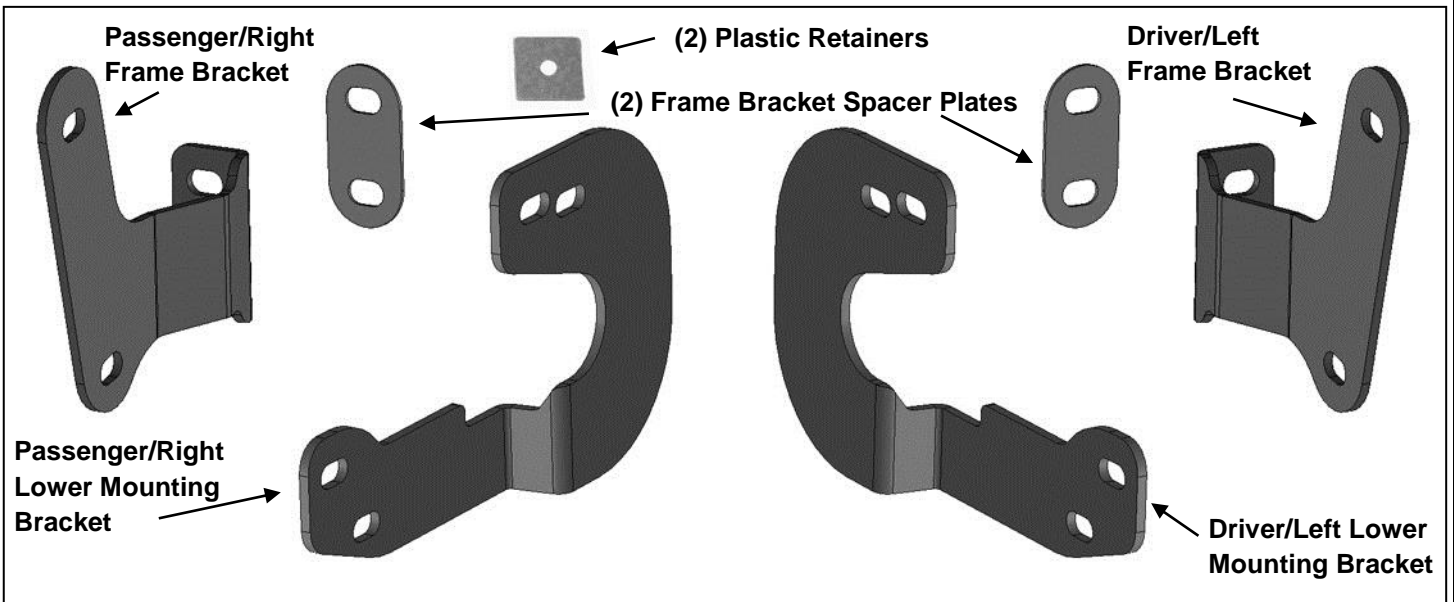

## INSTALLATION PROCEDURE:

**ASSISTANCE IS RECOMMENDED TO AVOID POSSIBLE INJURY OR DAMAGE TO THE VEHICLE.  
CUTTING IS REQUIRED.**

1. Starting at the front-driver side of the front bumper, remove the plastic cover, (if equipped), covering the bumper bolts on both sides of the tow hook, **(Figure 1)**. Remove the (2) outer bumper bolts, **(Figures 2 & 3)**. **IMPORTANT:** Do not remove the inner bumper bolts or the bumper may fall. Only remove the outer bumper bolts. **NOTE:** Cover cannot be reinstalled.

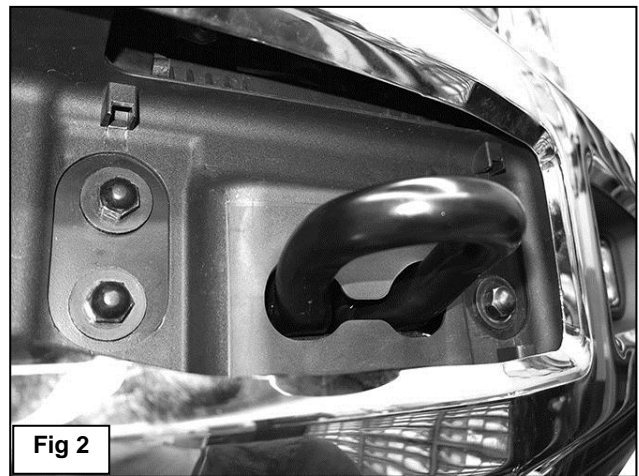
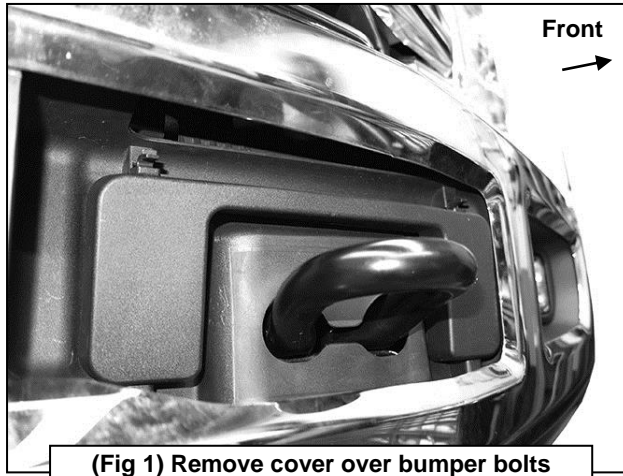

2. Select the driver side Frame Bracket and (1) Spacer Plate, **(Figure 4)**. Place the Spacer over the holes for the bumper bolts. Reuse the factory bumper bolts to attach the Frame Bracket to the Spacer and bumper, **(Figure 5)**. Make sure there is clearance between the top and bottom of the Frame Bracket and the opening in the bumper. Do not tighten hardware at this time.

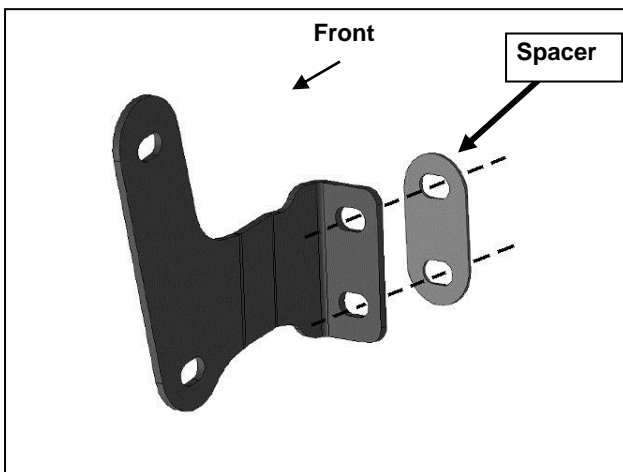

3. Repeat **Steps 1 & 2** for passenger side Frame Bracket and Spacer installation.

- Next, remove the plastic air dam from the bottom of the bumper and place it on a clean, stable work surface, **(Figure 6)**. Note the location and type of all factory hardware for reinstallation.



**(Fig 6) Remove plastic air dam from bumper**

- From under the driver side of the bumper, locate the (2) outer hex nuts attaching the frame extension to the outside of the frame, **(Figure 7)**. Remove (1) of the (2) factory hex nuts, **(Figures 8 & 9)**. Thread (1) Plastic Retainer onto the threaded end of the double bolt plate inside the frame. Remove the second factory nut from the bolt plate. **NOTE:** The Plastic Retainer is designed to help hold the factory double bolt plate in place in the frame and to help with bracket installation. Do not allow the double bolt plate to fall into the frame channel.



**(Fig 7) Driver/left frame extension pictured**

Remove (1) nut, thread (1) 12mm Plastic Retainer onto threaded end before removing remaining hex nut

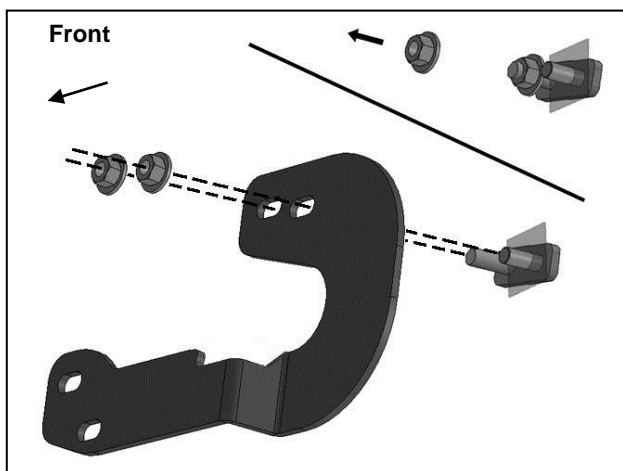

**(Fig 8) Driver/left Lower Bracket illustrated. Reuse factory hardware to attach Bracket to side of frame and frame extension**



**(Fig 9) Driver/left frame extension pictured**

- Select the driver side Lower Mounting Bracket. Reuse the (2) factory hex nuts to attach the Bracket to the double bolt plate, **(Figure 10)**. Do not tighten hardware at this time.

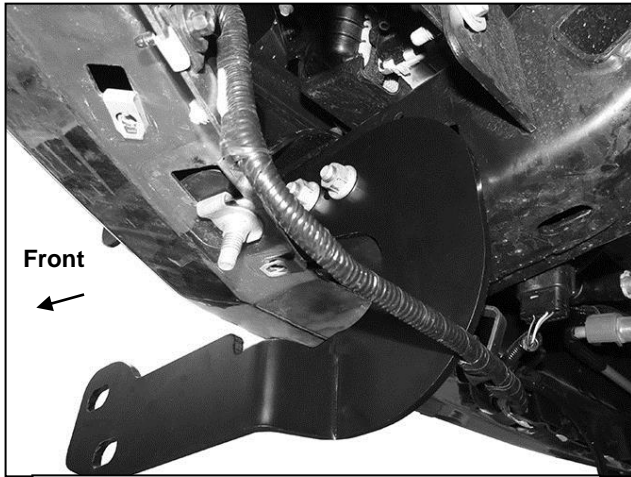

**(Fig 10) Driver/left Lower Bracket pictured.  
Reuse factory hardware to attach Bracket to  
side of frame and frame extension**

7. Repeat **Steps 5 & 6** for passenger side Lower Mounting Bracket installation.
8. With assistance, position the Grille Guard up to the outside of the Mounting Brackets. Attach the Grille Guard to the Frame Brackets with the included (4) 12mm x 35mm Hex Bolts, (8) 12mm Flat Washers, (4) 12mm Lock Washers and (4) 12mm Hex Nuts, **(Figure 11)**. Do not fully tighten hardware.

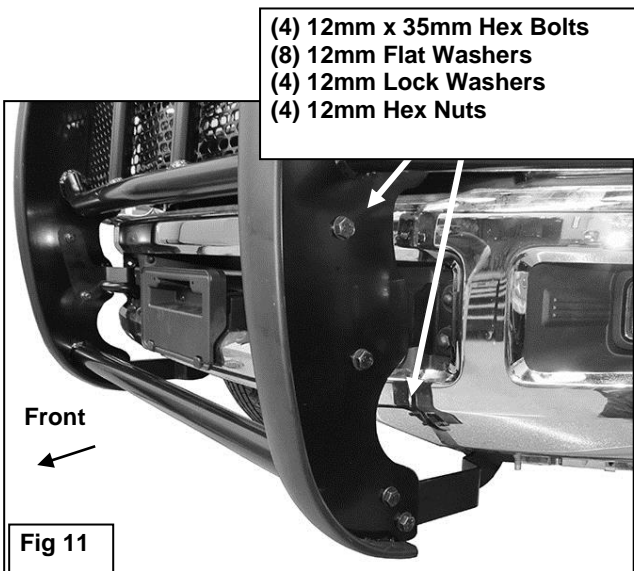

9. Attach the Grille Guard to the Lower Mounting Brackets with the included (4) 12mm x 35mm Hex Bolts, (8) 12mm Flat Washers, (4) 12mm Lock Washers and (4) 12mm Hex Nuts, **(Figure 11)**. Do not tighten hardware at this time.

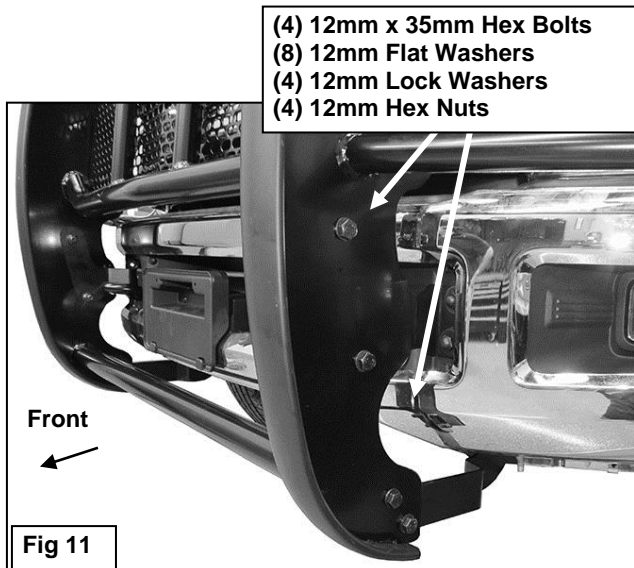

10. Level and adjust the Grille Guard and fully tighten the Bracket to vehicle hardware only at this time. Temporarily remove the Grille Guard.
11. Hold the plastic air dam up in position against the Lower Brackets and mark the location of the Brackets onto the top of the air dam, (**Figure 12**). Measure the location of the Lower Brackets and transfer these measurements onto the back of the air dam, (**Figures 13 & 14**). Place the air dam back up to the (2) Lower Mounting Brackets to verify location before cutting. Check all measurements on the vehicle. Once absolutely satisfied, use a hacksaw blade or utility knife to carefully cut (2) openings in air dam. Check fit, trim as necessary and reuse the factory hardware to reinstall air dam over Lower Brackets. **IMPORTANT:** On the "tall" air dam only, do not cut through the top or bottom edge of the air dam, (**Figure 13**). **NOTE:** It may be necessary to loosen or temporarily remove the Lower Mounting Brackets only to reinstall the air dam.

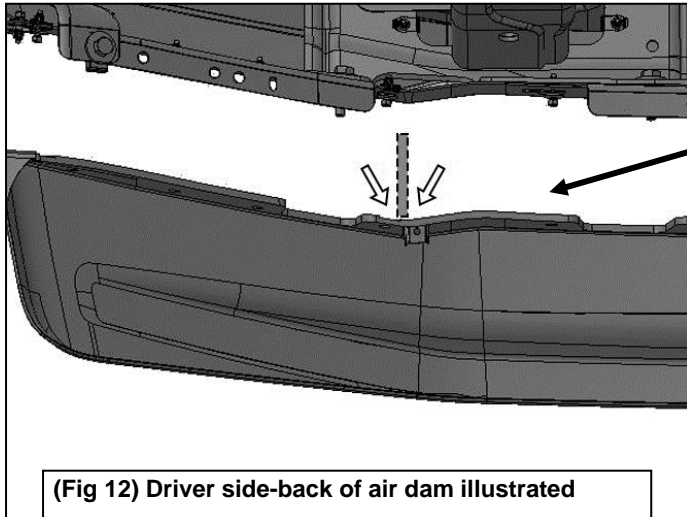

Hold air dam up against bottom of Brackets (dashed line for reference). Mark location of Bracket onto top of air dam (arrows)

(Fig 12) Driver side-back of air dam illustrated

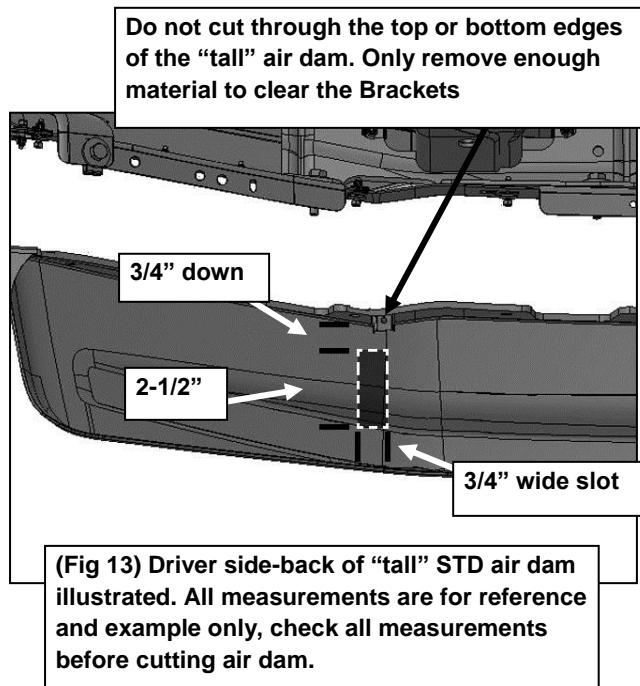

(Fig 13) Driver side-back of "tall" STD air dam illustrated. All measurements are for reference and example only, check all measurements before cutting air dam.

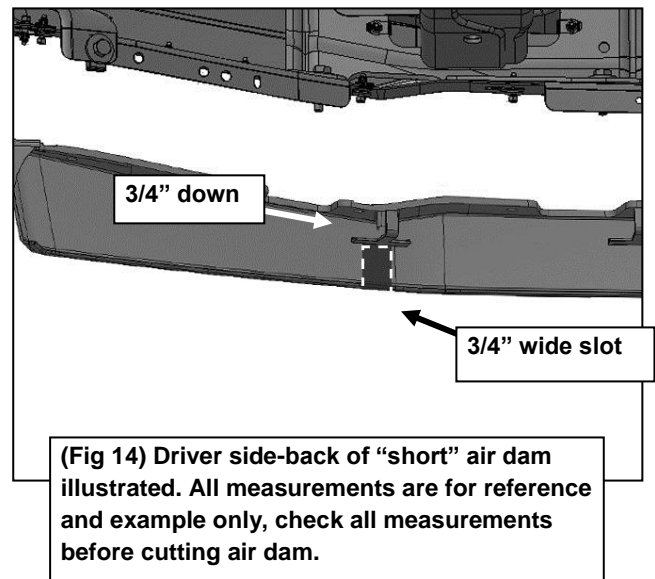

(Fig 14) Driver side-back of "short" air dam illustrated. All measurements are for reference and example only, check all measurements before cutting air dam.

12. Reinstall the Lower Brackets through the air dam if removed.
13. Reinstall the Grille Guard as described in **Steps 8 & 9**. Level and adjust Grille Guard and fully tighten all hardware. Reinstall the license plate and bracket.
14. On models with grille mounted camera, use included 2.5mm Wrench to remove center screen from Grille Guard, (**Figure 15**).

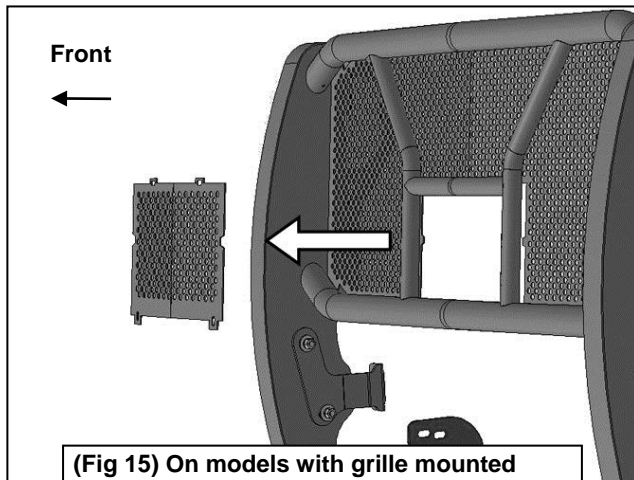

15. Do periodic inspections to the installation to make sure that all hardware is secure and tight.

