

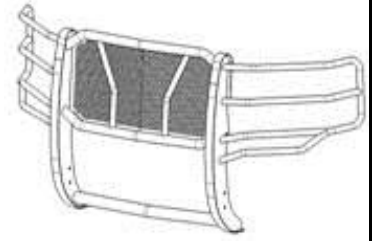

Extreme Grille Guard

Part No. E0508B



Fits: **2015 Ford F150**



60-180 min



Cutting Required



Drilling Not Required



REMOVE CONTENTS FROM BOX. VERIFY ALL PARTS ARE PRESENT.



READ INSTRUCTIONS CAREFULLY BEFORE STARTING INSTALLATION.

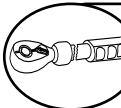

DO NOT OVER TORQUE. STANDARD OPERATING LOAD FOR TIGHTEN BODY MOUNT NUTS & BOLTS VARIES FROM **45** TO **65** FOOT POUND.

PARTS LIST:

Qty	Part Description	Qty	Part Description
1	Grille Guard	4	10-1.5mm x 30mm Hex Bolt
1	Driver/left Frame Bracket	8	10mm x 24mm OD x 2.2mm Flat Washer
1	Passenger/right Frame Bracket	4	10-1.5mm Nylon Locknut
1	Driver/left Top Bracket	2	8-1.25mm x 40mm Hex Bolt
1	Passenger/right Top Bracket	2	8-1.25mm x 30mm Hex Bolt
2	12-1.75mm Double Nut Plate	6	8mm x 22mm OD x 2mm Flat Washer
4	12-1.75 x 35mm Hex Bolt	2	8mm Lock Washer
4	12 x 32mm OD x 3mm Flat Washer	2	8-1.25mm Nylon Lock Nut
4	12mm Lock Washer		

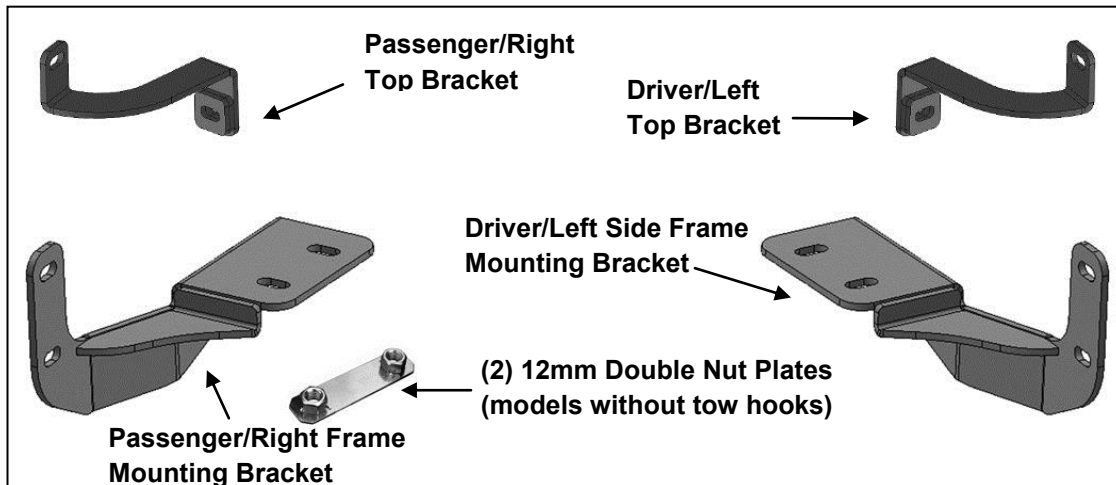

INSTALLATION PROCEDURE:

ASSISTANCE IS RECOMMENDED. CUTTING IS REQUIRED ON VEHICLES WITHOUT TOW HOOKS. INSTALLATION MAY INTERFERE WITH FRONT MOUNTED PARKING SENSORS.

NOTE: It may be necessary to remove/relocate the front license plate and license plate bracket on models equipped with Eco boost engine.

1. Determine if the vehicle is equipped with factory tow hooks, **(Figures 1 & 2)**.

Installation on vehicles with Factory Tow Hooks:

- Remove the driver side tow hook and plastic trim between tow hook and splash guard, **(Figure 1)**. **NOTE:** Do not move the nut plate inside the frame. Plastic trim will not be reinstalled.
- Select the driver side Frame Mounting Bracket, **(Figure 8)**. Insert the Bracket between the tow hook and the frame. Reattach the tow hook, (without trim), with the factory bolts. Leave hardware loose at this time.

- c. Repeat previous **Steps a & b** for passenger side Frame Bracket installation.
- d. Proceed to **Step 2**.

Installation on vehicles without Tow Hooks:

- a. From behind the bumper, release the clips attaching the plastic bumper pads to the steel bumper, (**Figures 3 & 4**). Temporarily remove the pads and license plate mounting bracket. Next, remove the air dam and plastic splash guard.
 - b. Insert (1) 12mm Double Nut Plate into the end of the driver side of the frame, (**Figures 5 & 6**). Line up the Nut Plate with the holes in the bottom of the frame, (**Figure 7**). **NOTE:** Use tape to extend end of Nut Plate for longer reach if necessary, (**Figure 5**).
 - c. Select the driver side Frame Mounting Bracket. Attach the Bracket to the bottom of the frame and Nut Plate with the included (2) 12mm x 35mm Hex Bolts, (2) 12mm Lock Washers and (2) 12mm Flat Washers, (**Figure 8**). Leave hardware loose at this time.
 - d. Repeat the previous **Steps a—c** for passenger side Frame Mounting Bracket installation.
 - e. Do not reinstall the plastic splash guard at this time, (See **Step 6**).
2. From under and behind the bumper, locate the top of the driver side bumper bracket, (**Figures 9, 10 & 12**). Next, locate the center bumper bolt attaching the top of the bumper bracket to the back of the bumper. It may be necessary to temporarily remove the rubber cover to access the bumper bolts, (**Figure 9**). Remove the hex bolt from the top-center of the bumper bracket, (**Figures 10 & 12**).
 3. Select the driver side Top Bracket, (**Figure 11**). Insert the Top Bracket, (end with welded spacer), into the space between the top of the bumper and the bottom of the grille. Line up the Bracket with the mounting hole in the bumper bracket. Attach the Bracket to the bumper bracket with the included (1) 8mm x 40mm Hex Bolt, (1) 8mm Lock Washer and (1) 8mm Flat washer, (**Figures 12—14**). Leave loose at this time.
 4. Repeat **Steps 2 & 3** to install the passenger side Top Bracket.
 5. **Models with Tow Hooks:** Proceed to **Step 6**.

Models without tow hooks:

- a. Hold the plastic splash guard up in place over the Frame Brackets.
 - b. Mark the location of the Brackets onto the back of the plastic splash guard, (**Figure 15**).
 - c. Use a sharp knife or hacksaw blade to cut slots out of the cover to clear the Brackets. For best results, start with a small slot and gradually increase the size until the Brackets fit through the guard. Do not cut through the front or rear edge of the splash guard, (**Figure 15**).
 - d. Reinstall the splash guard and air dam.
6. With assistance, place the Grille Guard up to the outside of the Frame Brackets. Attach the Grille Guard to the Brackets with (4) 10mm x 30mm Hex Bolts, (8) 10mm Flat Washers and (4) 10mm Nylon Lock Nuts, (**Figure 16A & 16B**). Snug but do not tighten hardware at this time.
 7. Center the Grille Guard on the vehicle. Once properly adjusted, fully tighten the (4) 12mm Hex Bolts attaching the Frame Brackets to the bottom of the frame and/or tow hook first, (**Figure 8**).
 8. Line up the driver side Top Bracket with the hole in the upright on the Grille Guard. Attach the Bracket to the Grille Guard with (1) 8mm x 30mm Hex Bolt, (2) 8mm Flat Washers, (1) 8mm Nylon Lock Nut, (**Figures 16A & 16B**). Do not fully tighten hardware at this time.
 9. Repeat **Step 8** to attach the passenger side Top Bracket to the Grille Guard.
 10. Align and adjust the Grille Guard and fully tighten all hardware.

Remove tow hooks and plastic trim around tow hooks

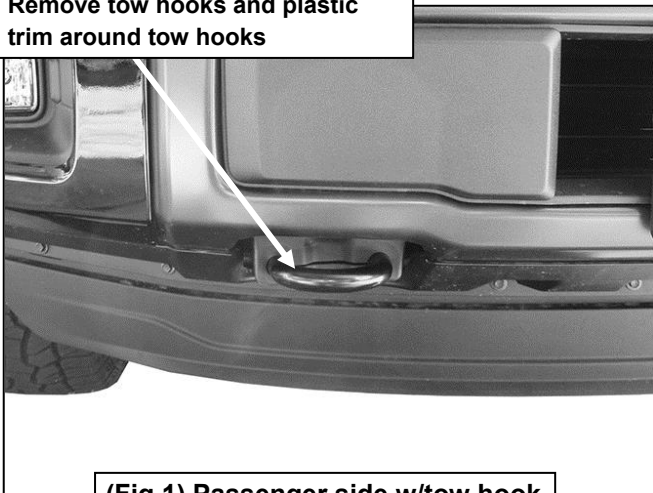

(Fig 1) Passenger side w/tow hook

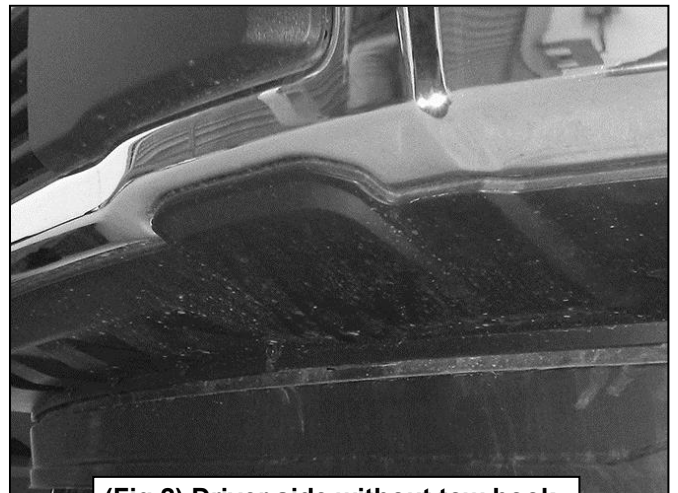

(Fig 2) Driver side without tow hook

Driver Side Installation Pictured

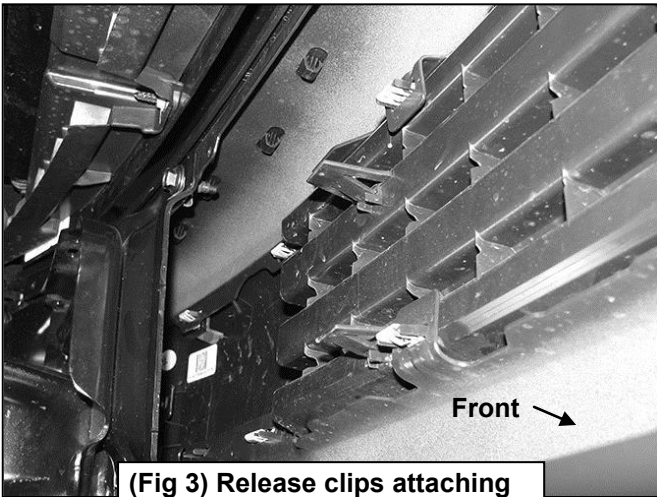

(Fig 3) Release clips attaching bumper pad to steel bumper

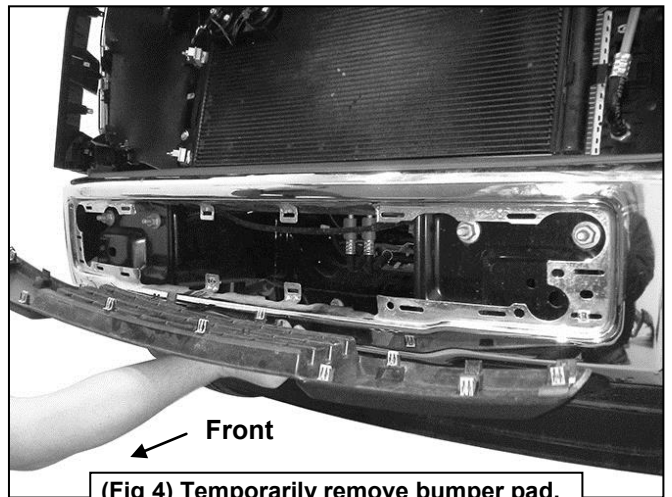

(Fig 4) Temporarily remove bumper pad. Grille removed for instruction purposes only, do not remove grille

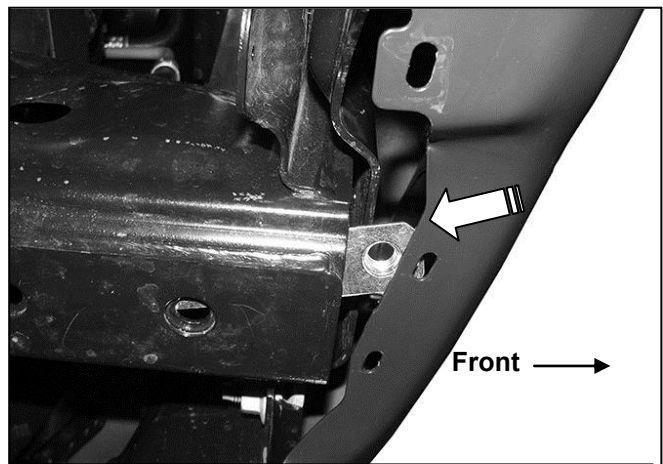
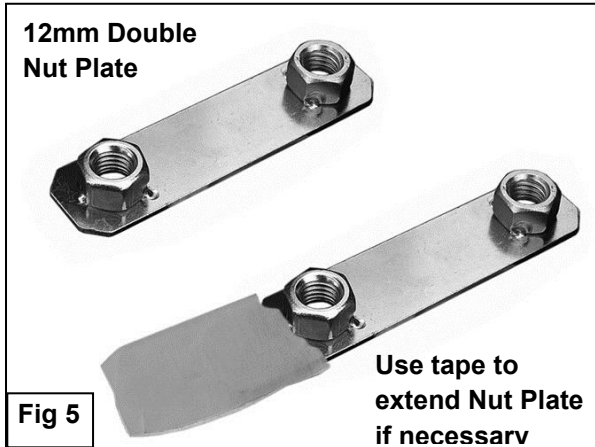

(Fig 6) Insert Nut Plate into open end of frame- applies to models without tow hooks only

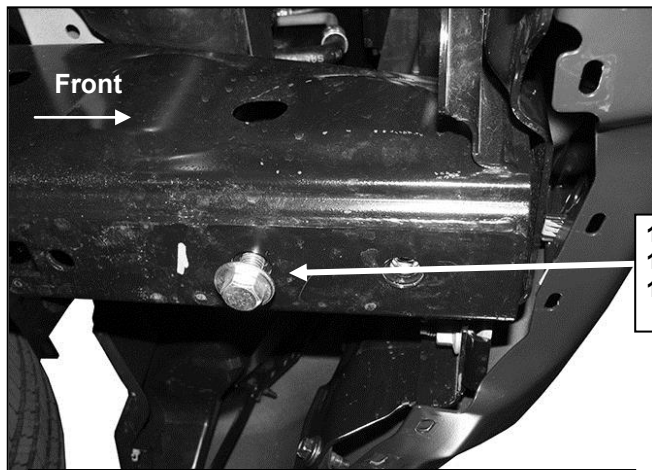

(Fig 7) Use a Hex Bolt to line up the Nut Plate

Pictured without lower splash guard for instruction purposes only

Driver Side Installation Pictured

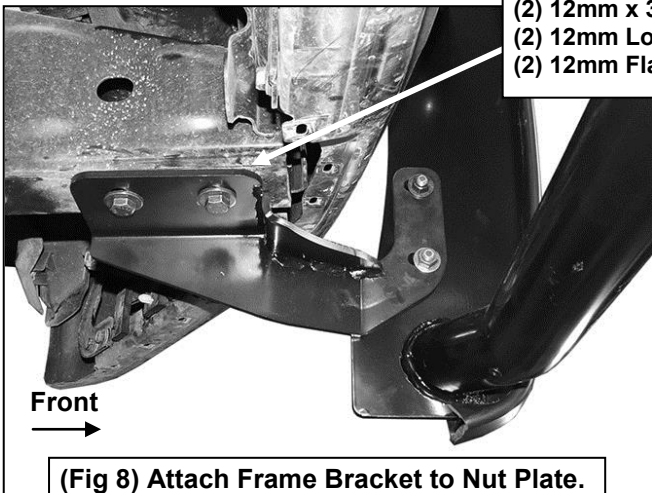

(2) 12mm x 35mm Hex Bolts
(2) 12mm Lock Washers
(2) 12mm Flat Washers

(Fig 8) Attach Frame Bracket to Nut Plate. Grille Guard pictured for reference only

Pictured without lower splash guard for instruction purposes only

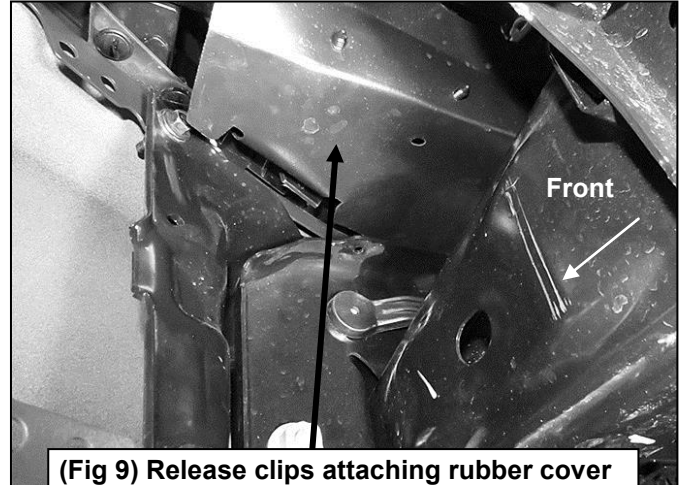

(Fig 9) Release clips attaching rubber cover to back of bumper above bumper brackets

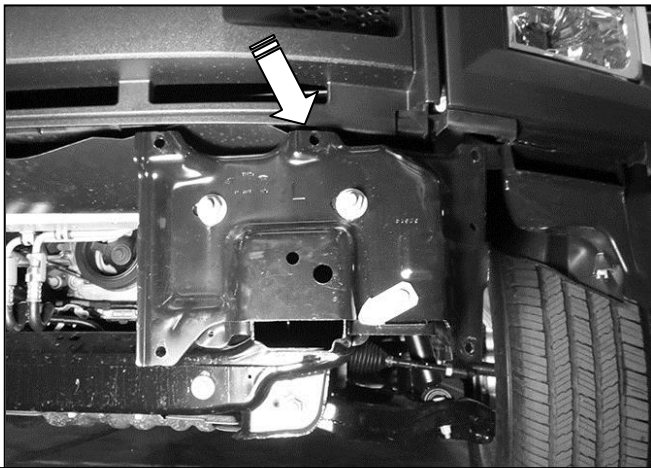

(Fig 10) Locate the top bumper bolts. Remove the driver side middle bolt (see arrow-bumper pictured removed for reference only-do not remove bumper)

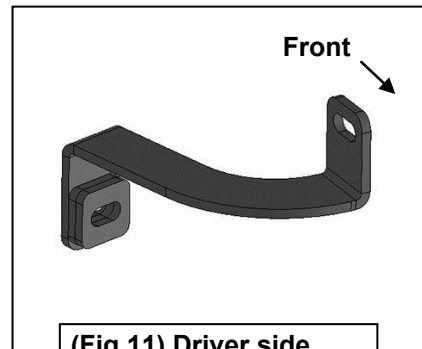

(Fig 11) Driver side Top Bracket illustrated

8mm x 40mm Hex Bolt
8mm Lock Washer
8mm Flat Washer

From behind bumper, release clips attaching rubber cover to back of bumper above bumper brackets to access the bumper bolts (Fig 7). Insert the Top Bracket (Fig 9 & 12) into gap between top of bumper and bottom of grille.

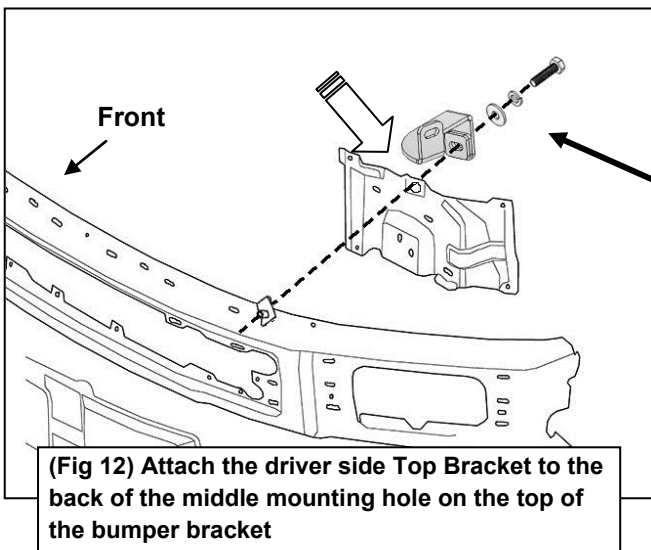

(Fig 12) Attach the driver side Top Bracket to the back of the middle mounting hole on the top of the bumper bracket

Driver Side Installation Pictured

8mm x 40mm Hex Bolt
8mm Lock Washer
8mm Flat Washer

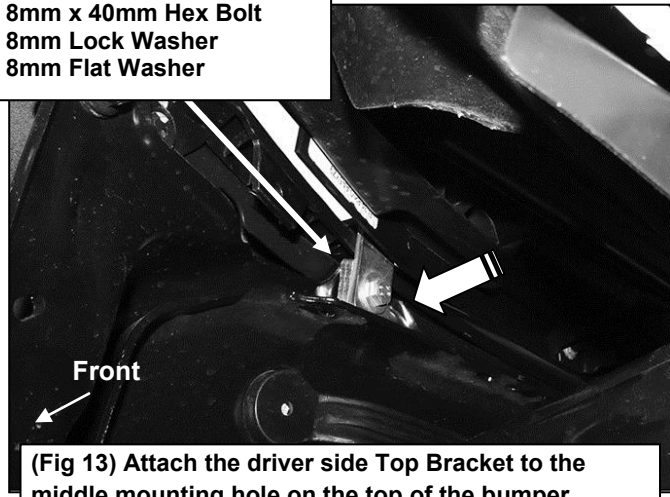

(Fig 13) Attach the driver side Top Bracket to the middle mounting hole on the top of the bumper bracket (pictured from behind bumper)

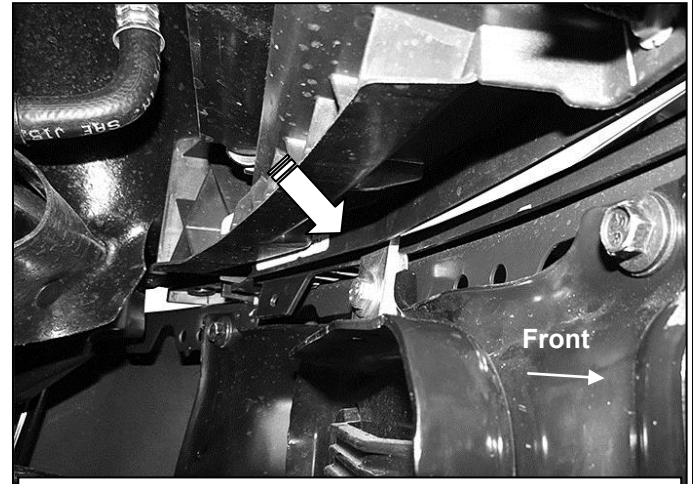

(Fig 14) Attach the driver side Top Bracket to the middle mounting hole on the top of the bumper bracket (pictured from behind center of bumper)

Do not cut through front or back edge of splash guard

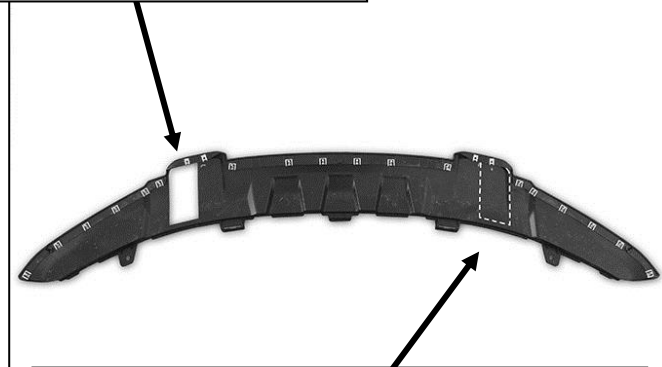

Fig 15) Hold the splash guard up to the bottom of Frame Brackets. Trace location of Brackets onto back of the plastic cover (dashed line). Cut as required to clear brackets

8mm x 30mm Hex Bolt
(2) 8mm Flat Washers
8mm Nylon Lock Nut

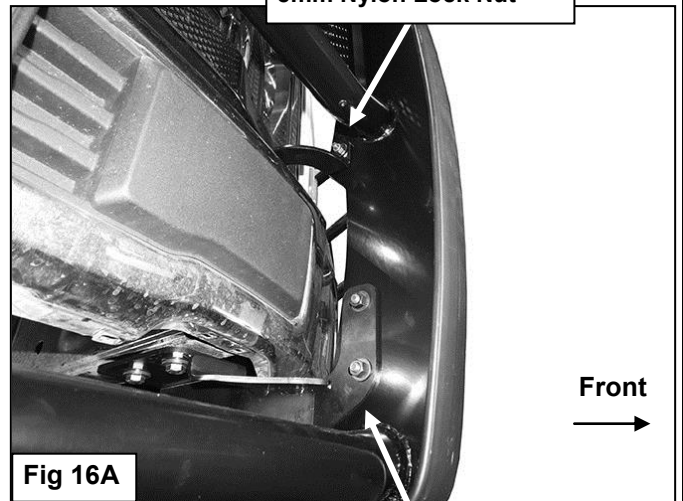

Fig 16A

(2) 10mm x 30mm Hex Bolts
(4) 10mm Flat Washers
(2) 10mm Nylon Lock Nuts

Pictured without lower splash guard for instruction purposes only

8mm x 30mm Hex Bolt
(2) 8mm Flat Washers
8mm Nylon Lock Nut

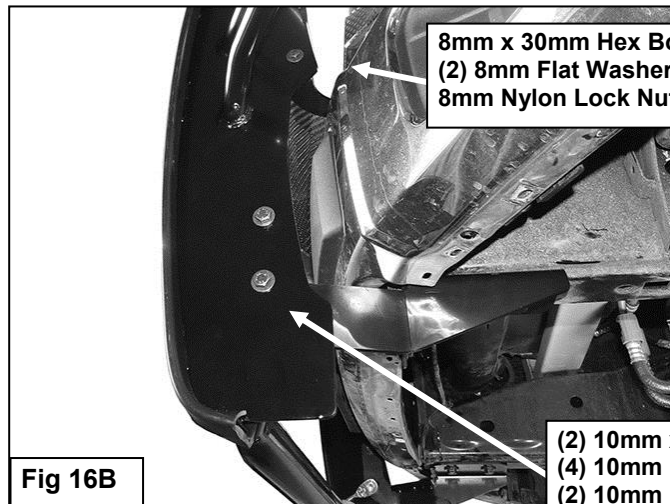

Fig 16B

(2) 10mm x 30mm Hex Bolts
(4) 10mm Flat Washers
(2) 10mm Nylon Lock Nuts

PRODUCT CARE

- Periodically check the product to ensure all fasteners are tight and components are intact.
- Regular waxing is recommended to protect the finish of the product.
- **Use ONLY Non-Abrasive automotive wax.** Use of any soap, polish or wax that contains an abrasive is detrimental and can scratch the finish leading to corrosion.
- Aluminum polish may be used to polish small scratches and scuffs for **Stainless Steel finish.**
- Mild soap may be used to clean the product for both **Stainless Steel and Black finish.**

1. **Hardware's are not of correct size.**

In GMC / Chevrolet truck model 2006 & up, customer needs to reuse the factory body bolts to install the bracket. If your vehicle is not GMC / Chevrolet 2006 & up, ensure that holes are not partially covered with any plastic grommet or rust? If it is, remove the plastic grommet & rust from the thread holes & re-try the installation.

2. **Mounting Bracket are not getting Installed properly.**

In some cases Illustration images shown in Installation manual may not be the exactly same as per actual vehicle images ,also if Driver / Passenger side mounting brackets are very identical in the design, suggest referring Parts Identification guide to avoid fitment issue.

3. **Products are thumping / rattling after installation.**

Ensure that all required mounting brackets / hardware's are installed & tighten correctly. Suggest using white lithium / regular grease between the metal to metal contact surfaces.

4. **Side Bar is not aligning with vehicle / Step Pads are not aligning with vehicle doors.**

Side bar may be interchanged or mounting brackets are not installed at the correct position in the vehicle. Refer Parts identification guide.

5. **Missing / Excess Hardware.**

Recheck hardware count as per the part list.

6. **Product not installing properly.**

Ensure make model year, cab length and bed size of your vehicle is listed in the application. All installation steps are followed correctly.