

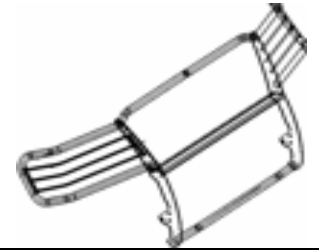

Grille Guard

Part No. E0037B/S



Fits: Current Ford Ranger

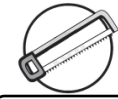

60-180 min

Cutting Maybe Required

Drilling Not Required



REMOVE CONTENTS FROM BOX. VERIFY ALL PARTS ARE PRESENT.



READ INSTRUCTIONS CAREFULLY BEFORE STARTING INSTALLATION.

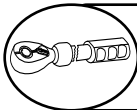

DO NOT OVER TORQUE. STANDARD OPERATING LOAD FOR TIGHTEN BODY MOUNT NUTS & BOLTS VARIES FROM 45 TO 65 FOOT POUND.

PARTS LIST:

Qty	Part Description	Qty	Part Description
1	Grille Guard	4	12mm Lock Washers
1	Driver/left Frame Bracket	4	10-1.5mm x 35mm Hex Bolts
1	Passenger/Right Frame Bracket	8	10mm x 27mm OD x 3 mm Flat Washers
1	Driver/left Top Bracket	4	10-1.5mm Nylon Lock Nuts
1	Passenger/Right Top Bracket	2	8-1.25mm x 25mm Hex Bolts
4	12-1.75mm x 45mm Hex Bolts	4	8mm x 16mm x 1.6 mm Flat Washers
4	12mm x 44mm x 4mm Large Flat Washers	2	8mm Nylon Lock Nuts

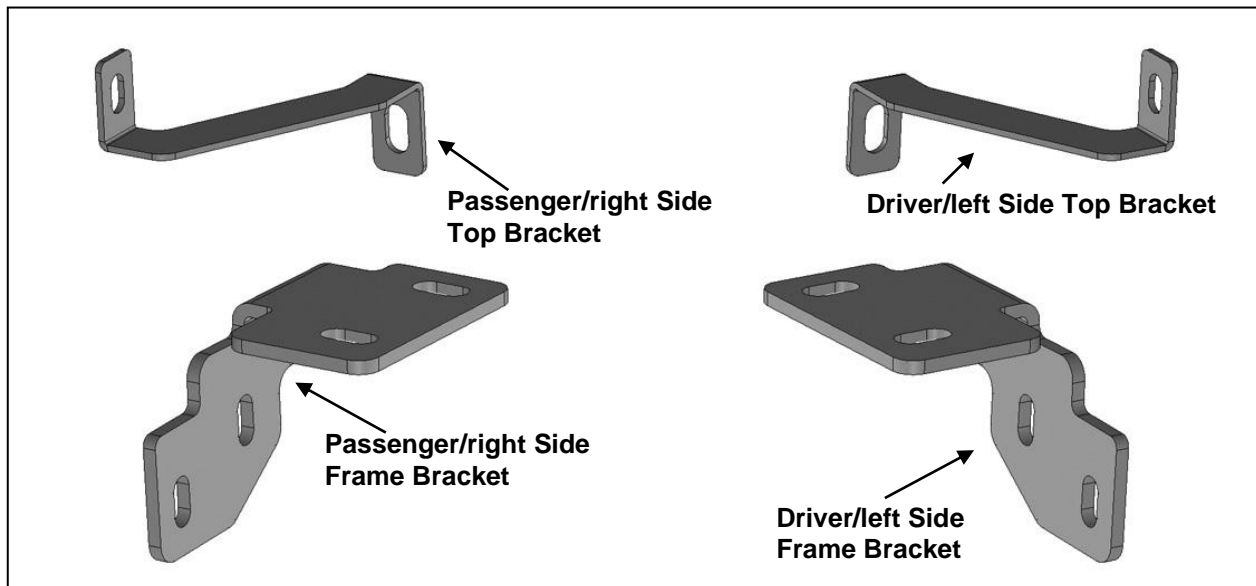

PROCEDURE:

REMOVE CONTENTS FROM BOX AND VERIFY ALL PARTS ARE PRESENT. READ INSTRUCTIONS CAREFULLY. CUTTING MAY BE REQUIRED. ASSISTANCE IS RECOMMENDED. INSTALLATION MAY INTERFERE WITH FRONT MOUNTED SENSORS.

1. Start installation from under the front of the vehicle.
2. Determine if the vehicle is equipped with tow hooks, (Figure 1).

Tow Hook equipped vehicles:

- a. Remove the plastic cover attached to the tow hook, **(Figure 1)**. Next, remove the tow hook from the bottom of the frame, **(Figures 2—4)**. On models with steel skid plate, temporarily remove skid plate, **(Figure 3)**.
- b. Proceed to **Step 3**.

Vehicles without tow hooks:

- a. Cut out the lower section of the indented area in both sides of the plastic bumper to clear the Brackets as pictured, **(Figure 5)**. **NOTE:** Hold the Frame Mounting Bracket up to the back of the bumper to determine area to remove to clear Bracket. **IMPORTANT:** Make several small cuts for best fit.
 - b. Insert the Mounting Brackets through the openings in the bumper to check for clearance around Brackets and hardware. Trim the plastic as required to clear the Brackets.
3. Select the driver/left Frame Mounting Bracket, **(Figure 6)**. Hold the Bracket up to the bottom of the frame. Line up the holes in the Bracket with the (2) mounting bolt holes for the tow hook.

Models without tow hooks:

- a. Attach the Bracket to the threaded holes in the frame with (2) 12mm x 45mm Hex Bolts, (2) 12mm Lock Washers and (2) 12mm Flat Washers, **(Figures 6 & 7)**.
- b. Repeat to attach the passenger/right Frame Bracket.

Models with tow hooks:

- a. Install the Bracket between the tow hook and the bottom of the frame, **(Figure 7)**.
 - b. Attach the Bracket and tow hook to the threaded holes in the frame with (2) 12mm x 45mm Hex Bolts, (2) 12mm Lock Washers and (2) 12mm Flat Washers, **(Figures 6 & 7)**. Leave hardware loose.
 - c. Repeat previous **Steps** to attach the passenger/right Frame Bracket and tow hook.
4. Next, from behind/below the driver/left side of the front bumper, locate and remove the top bumper bracket bolt, **(Figures 8 & 9)**. Apply removable tape (masking tape for example) to the top of the bumper in line with the factory bumper bolt, **(Figures 10 & 12)**.
5. Select the driver/left Top Bracket, **(Figures 10 & 11)**. Carefully slide the inner end of the Bracket through the gap between the lower bumper and upper plastic fascia panel. Reuse the factory bumper bolt to attach the Top Bracket to the back of the bumper bracket, **(Figure 12)**.
6. Repeat **Steps 4 & 5** to install the passenger/right Top Bracket.
7. With assistance, hold the Grille Guard up in position on the outside of the Mounting Brackets. Attach the Grille Guard to the Frame Mounting Brackets with the included (4) 10mm x 35mm Hex Bolts, (8) 10mm Flat Washers and (4) 10mm Nylon Lock Nuts, **(Figures 13 & 14)**. Do not tighten hardware at this time.
8. Attach the Grille Guard to the Top Brackets with (2) 8mm x 25mm Hex Bolts, (4) 8mm Flat Washers and (2) 8mm Nylon Lock Nuts, **(Figure 15)**.
9. Check the Grille Guard for alignment with the vehicle and for clearance between the Grille Guard and the bumper. Adjust as required then fully tighten all hardware.
10. Do periodic inspections to the installation to make sure that all hardware is secure and tight.



(Fig 1) Example of Tow hook

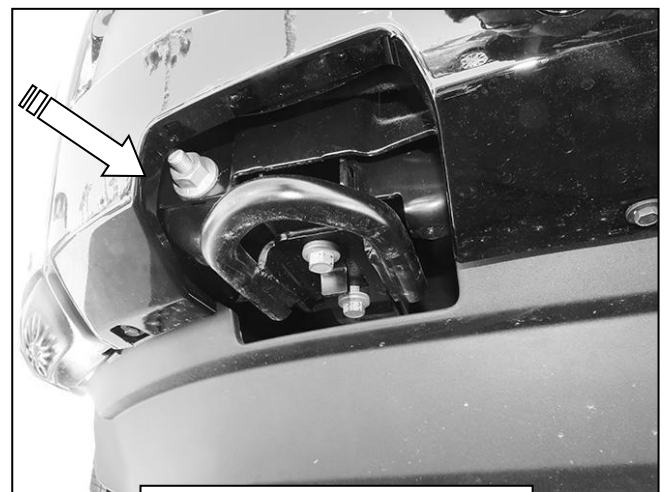

(Fig 2) Remove plastic cover surrounding tow hook

Driver/left Side Installation Pictured



(Fig 3) Models with steel skid plate, temporarily remove skid plate to access tow hooks



(Fig 5) Models without tow hooks, cut openings in lower plastic cover to clear Brackets



(Fig 7) Driver/left Frame Bracket installed with tow hook

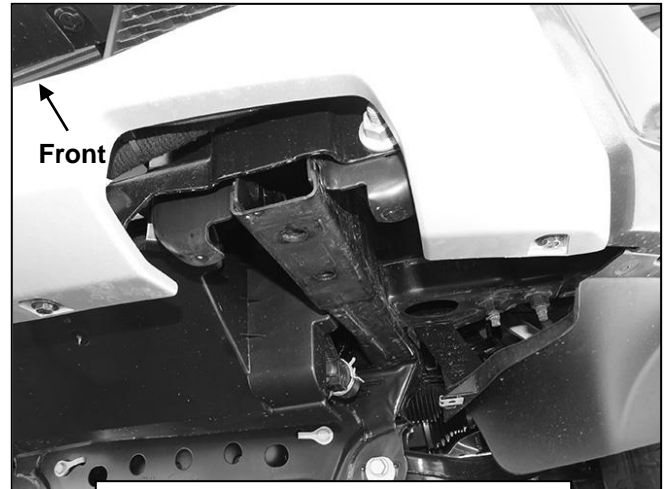

(Fig 4) Driver/left mounting location

- (2) 12mm Hex Bolts
- (2) 12mm Lock Washers
- (2) 12mm Flat Washers

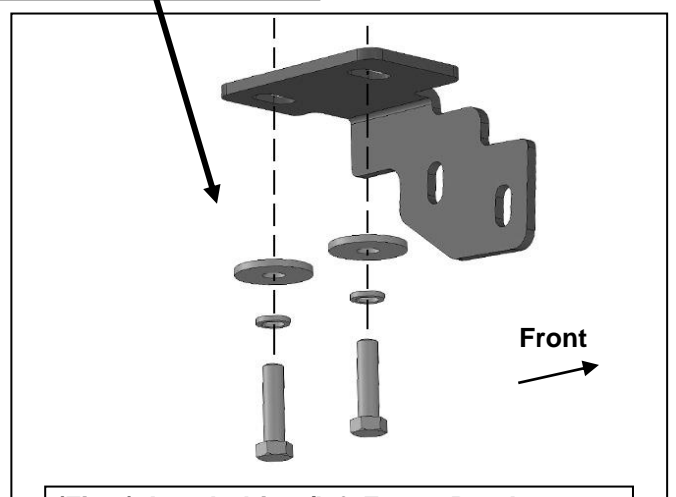

(Fig 6) Attach driver/left Frame Bracket to bottom of frame. Models with tow hooks, install Bracket between tow hook and frame

Driver/left Side Installation Pictured

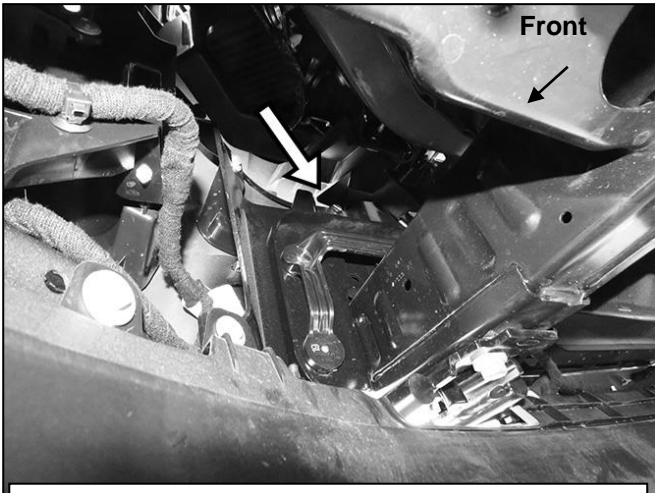

(Fig 8) Remove top bumper bracket bolt (arrow). Driver/left side pictured from below and behind bumper (also see Fig 9)

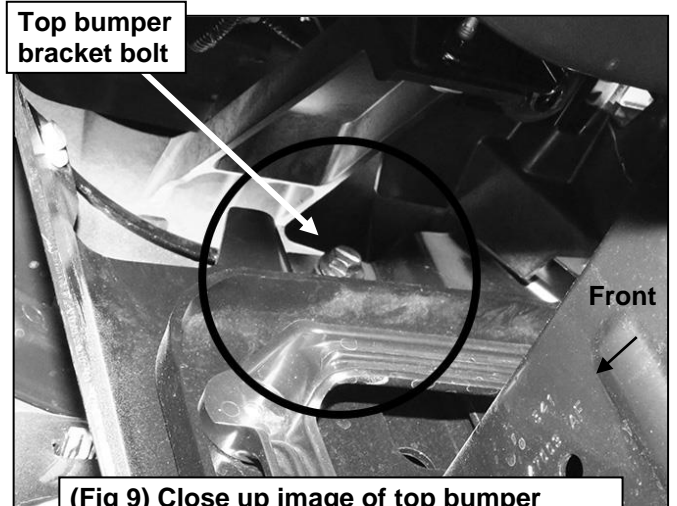

(Fig 9) Close up image of top bumper bracket bolt. Driver/left side pictured from below and behind bumper (also see Fig 8)

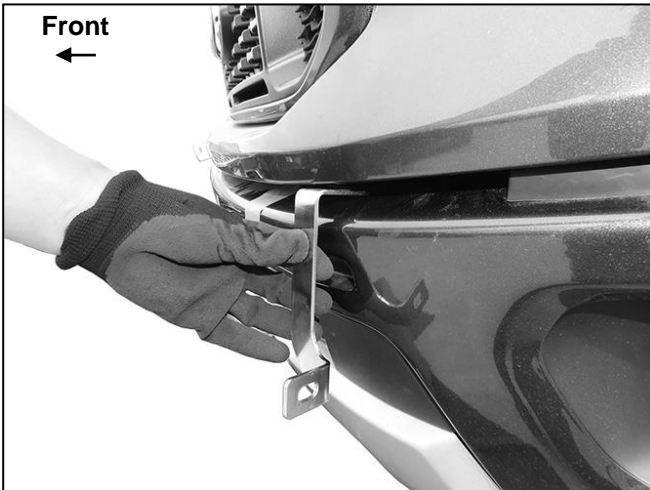

(Fig 10) Carefully insert bent end of driver/left Top Bracket through gap between lower bumper and upper plastic fascia panel. Use removable tape to protect finish on bumper

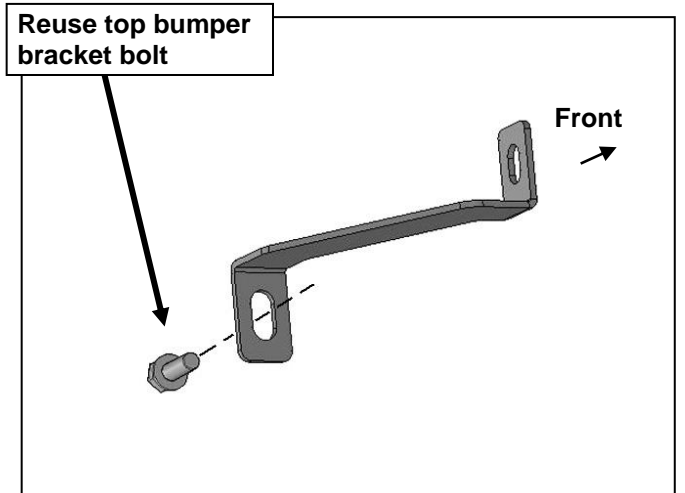

(Fig 11) Reuse bumper bracket bolt to attach driver/left Top Bracket to back of bumper bracket



(Fig 12) Top Brackets installed

- (2) 10mm Hex Bolts**
- (4) 10mm Flat Washers**
- (2) 10mm Nylon Lock Nuts**

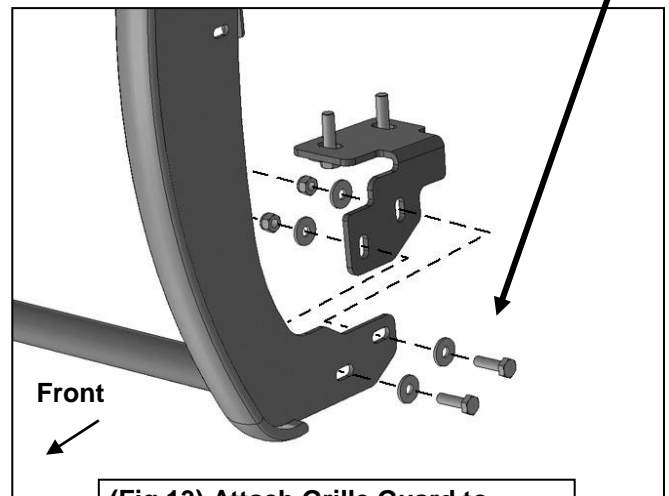

(Fig 13) Attach Grille Guard to outside of driver/left Frame Bracket

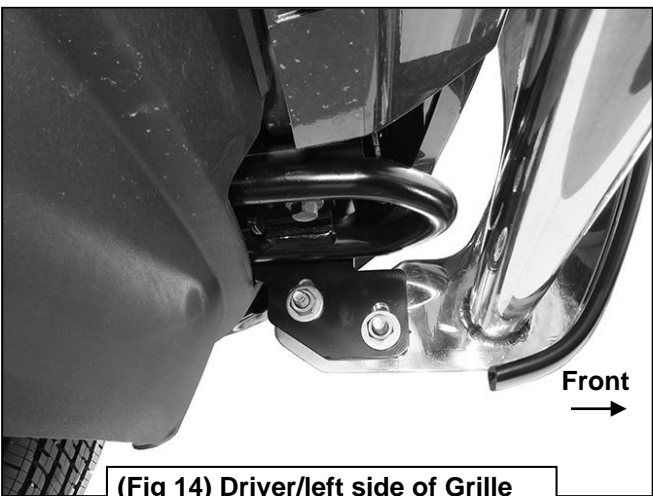

(Fig 14) Driver/left side of Grille Guard attached to Frame Bracket

- 8mm Hex Bolt**
- (2) 8mm Flat Washers**
- 8mm Nylon Lock Nut**

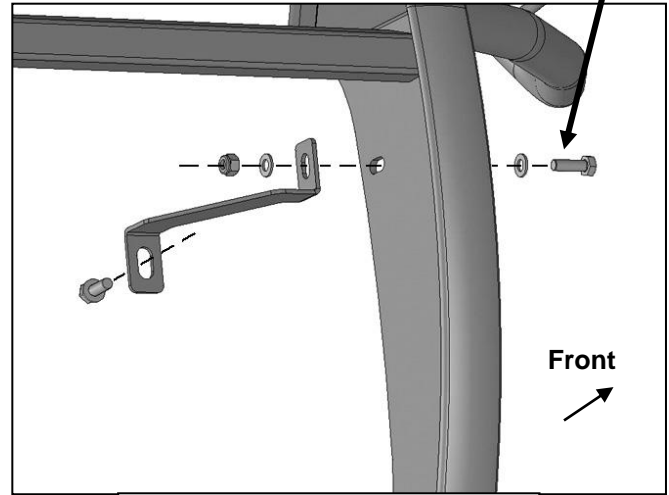

(Fig 15) Driver/left side of Grille Guard attached to Top Bracket



No.	Parts Identification
1	Passenger / Right 'Rear' Bracket marked "PR"
2	Driver / Left 'Rear' Bracket marked "DR"
3	Passenger / Right 'Center' Bracket marked "PC"
4	Driver / Left 'Center' Bracket marked "DC"
5	Passenger / Right 'Front' Bracket marked "PF"
6	Driver / Left 'Front' Bracket marked "DF"

Note:

- > This guide is to identify the parts and not a reference for part count.
- > For part count, refer Parts List.
- > Product / Bracket image is representative and actual design may vary.

PRODUCT CARE

- Periodically check the product to ensure all fasteners are tight and components are intact.
- Regular waxing is recommended to protect the finish of the product.
- **Use ONLY Non-Abrasive automotive wax.** Use of any soap, polish or wax that contains an abrasive is detrimental and can scratch the finish leading to corrosion.
- Aluminum polish may be used to polish small scratches and scuffs for **Stainless Steel finish.**
- Mild soap may be used to clean the product for both **Stainless Steel and Black finish.**

FAQ's

1. Hardware's are not of correct size.

In GMC / Chevrolet truck model 2006 & up, customer needs to reuse the factory body bolts to install the bracket. If your vehicle is not GMC / Chevrolet 2006 & up, ensure that holes are not partially covered with any plastic grommet or rust? If it is, remove the plastic grommet & rust from the thread holes & re-try the installation.

2. Mounting Bracket are not getting Installed properly.

In some cases Illustration images shown in Installation manual may not be the exactly same as per actual vehicle images ,also if Driver / Passenger side mounting brackets are very identical in the design, suggest referring Parts Identification guide to avoid fitment issue.

3. Products are thumping / rattling after installation.

Ensure that all required mounting brackets / hardware's are installed & tighten correctly. Suggest using white lithium / regular grease between the metal to metal contact surfaces.

4. Side Bar is not aligning with vehicle / Step Pads are not aligning with vehicle doors.

Side bar may be interchanged or mounting brackets are not installed at the correct position in the vehicle. Refer Parts identification guide.

5. Missing / Excess Hardware.

Recheck hardware count as per the part list.

6. Product not installing properly.

Ensure make model year, cab length and bed size of your vehicle is listed in the application. All installation steps are followed correctly.

Check out these other TrailFX Products!!



Keystone Automotive Operations Inc. (KAO) warrants this product to be free of defects in material and workmanship at the time of purchase by the original retail consumer. KAO disclaims any other warranties, express or implied, including the warranty of fitness for a particular purpose or an intended use. If the product is found to be defective, KAO may replace or repair the product at our option, when the product is returned prepaid, with proof of purchase. Alteration to, improper installation, or misuse of this product voids the warranty. KAO's liability is limited to repair or replacement of products found to be defective, and specifically excludes liability for any incidental or consequential loss or damage.