

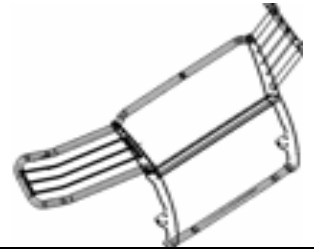

# Grille Guard

## Part No. E0035B/S



**Fits: Current Silverado 1500**  
**Excl. Diesel Models With Def Tanks & 2019 Silverado 1500 LD**



60-180 min

Cutting Maybe Required

Drilling Not Required



REMOVE CONTENTS FROM BOX. VERIFY ALL PARTS ARE PRESENT.



READ INSTRUCTIONS CAREFULLY BEFORE STARTING INSTALLATION.

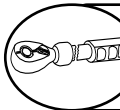

DO NOT OVER TORQUE. STANDARD OPERATING LOAD FOR TIGHTEN BODY MOUNT NUTS & BOLTS VARIES FROM **45** TO **65** FOOT POUND.

### PARTS LIST:

Qty	Part Description	Qty	Part Description
1	Grille Guard Assembly	6	12mm Lock Washers
2	Frame Mounting Brackets	6	12-1.75mm Hex Nuts
1	Driver/Left GG Mounting Bracket	6	10-1.50mm x 30mm Hex Bolts
1	Passenger/Right GG Mounting Bracket	12	10mm x 27mm OD x 3mm Flat Washers
1	Driver/Left Top Bracket	6	10mm Lock Washers
1	Passenger/Right Top Bracket	6	10-1.50mm Hex Nuts
2	12-1.75mm x 30mm Double Bolt Plates	6	8-1.25mm x 30mm Hex Bolts
2	12-1.75mm x 35mm Single Bolt Plates	6	8mm x 24mm OD x 2mm Flat Washers
6	12mm x 24mm OD x 2.5mm Flat Washers	6	8mm Lock Washers
		2	Adhesive Backed Foam Tapes

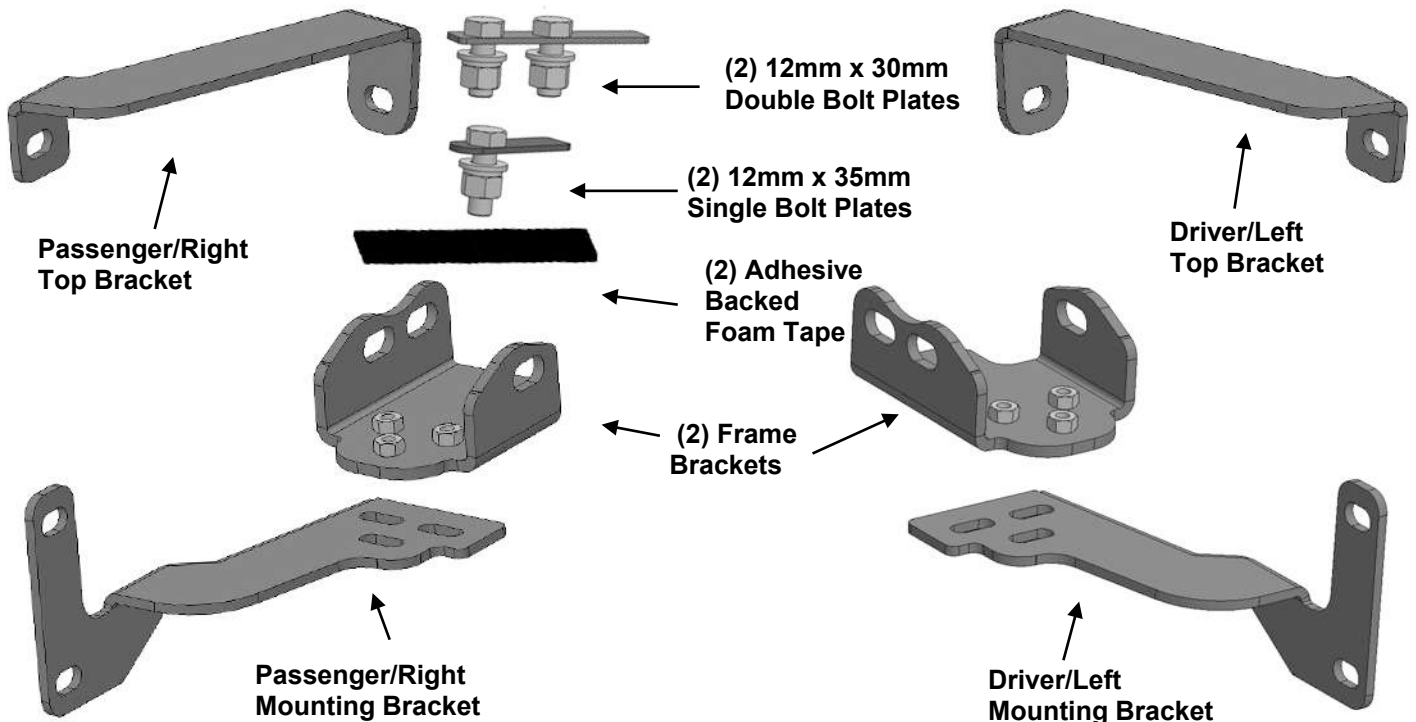

## PROCEDURE:

**REMOVE CONTENTS FROM BOX AND VERIFY ALL PARTS ARE PRESENT. READ INSTRUCTIONS CAREFULLY. CUTTING MAY BE REQUIRED. ASSISTANCE IS HIGHLY RECOMMENDED. INSTALLATION MAY INTERFERE WITH FRONT MOUNTED SENSORS.**

1. Remove the factory tow hooks and hardware if equipped, **(Figures 1—3)**. **IMPORTANT:** Tow hooks cannot be reinstalled with the Grille Guard.

### **Vehicles without tow hooks:**

- a. Cut out the indented area in both sides of the plastic bumper insert to clear the Brackets as pictured, **(Figure 4 & 5)**. **IMPORTANT:** Make several small cuts for best fit. Do not cut through the top or bottom edge of the panel.
2. Select the driver side Frame Bracket and Mounting Bracket, **(Figure 6)**. Attach the Mounting Bracket to the bottom of the Frame Bracket with (3) 8mm x 30mm Hex Bolts, (3) 8mm Lock Washers and (3) 8mm Flat Washers, **(Figure 6)**. Do not tighten hardware at this time.
  3. Insert the Frame Bracket assembly through the opening in the bumper, **(Figures 3 & 4)**. **NOTE:** Trim the opening to clear the Bracket assembly as necessary. Line up the holes in the Frame Bracket with the holes in the end of the frame for the tow hook. Select (1) 12mm Double Bolt Plate, **(Figure 7)**. Insert the Double Bolt Plate into the end of the frame, through the (2) holes in the side of the frame and out through the Frame Bracket, **(Figures 9, 10B & 11)**. Secure the Frame Bracket to the Bolt Plate with (2) 12mm Flat Washers, (2) 12mm Lock Washers and (2) 12mm Hex Nuts. Snug but do not fully tighten hardware at this time.
  4. Select (1) 12mm Single Bolt Plate, **(Figure 8)**. Secure Frame Bracket to the Bolt Plate with (1) 12mm Flat Washer, (1) 12mm Lock Washer and (1) 12mm Hex Nut, **(Figures 9, 10A & 11)**. Snug but do not tighten at this time.
  5. Repeat **Steps 2—4** to install the passenger/right Frame Mounting Bracket assembly.
  6. Open the hood and remove the cover between the top of the radiator and the grille, **(Figure 12)**.
  7. Carefully remove the grille from the vehicle. **NOTE:** Grille is held in place with screws at the top and several clips. Remove the screws and firmly pull the grille straight out from the vehicle to release the grille from clips, **(Figure 13)**.
  8. Move up to the top of the bumper. Select the Driver/left Top Bracket. Apply a layer of the included Adhesive Backed Foam Tame to the bottom of the Bracket, **(Figure 14)**.
  9. Locate the (2) factory hex bolts attaching the top of the bumper to the inner bumper bracket. Remove the outer hex bolt, **(Figure 15)**. Reuse the factory outer hex bolt to attach the Top Bracket to the back of the bumper, **(Figure 16)**. Do not tighten hardware at this time.
  10. Repeat **Steps 6—9** to install the passenger/right Top Bracket.
  11. With assistance, hold the Grille Guard up in position on the outside of the Mounting Brackets, **(Figure 17)**. Attach the Grille Guard to the Brackets with (6) 10mm Hex Bolts, (12) 10mm Flat Washers, (6) 10mm Lock Washers and (6) 10mm Hex Nuts, **(Figures 18 & 19)**. Do not tighten hardware at this time.
  12. Check the Grille guard alignment with the vehicle. Adjust as required then fully tighten the Bracket to vehicle hardware only. Do not fully tighten the Grille Guard to Bracket hardware at this time.
  13. Reinstall the grille and top cover. **NOTE:** Loosen the hardware attaching the Grille Guard to the Brackets and tilt the Grille Gard forward to make room to reinstall the grille. Reinstall the Grille Guard. Level and adjust the Grille Guard and fully tighten all hardware.
  14. Do periodic inspections to the installation to make sure that all hardware is secure and tight.

### **Driver Side Mounting Bracket Installation Pictured**

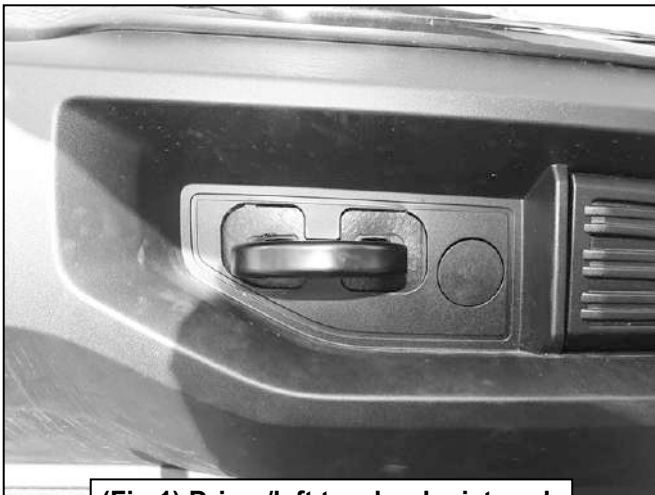

**(Fig 1) Driver/left tow hook pictured**

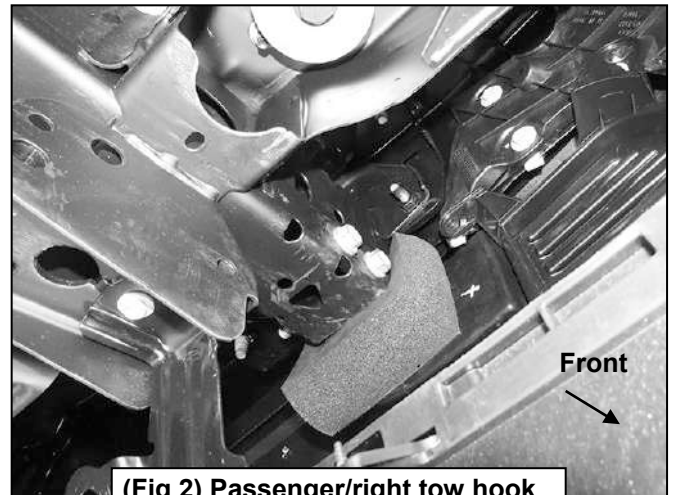

**(Fig 2) Passenger/right tow hook pictured from behind bumper**

## Driver Side Mounting Bracket Installation Pictured



(Fig 3) Tow hook removed. Opening may need to be trimmed to clear the Mounting Bracket assembly

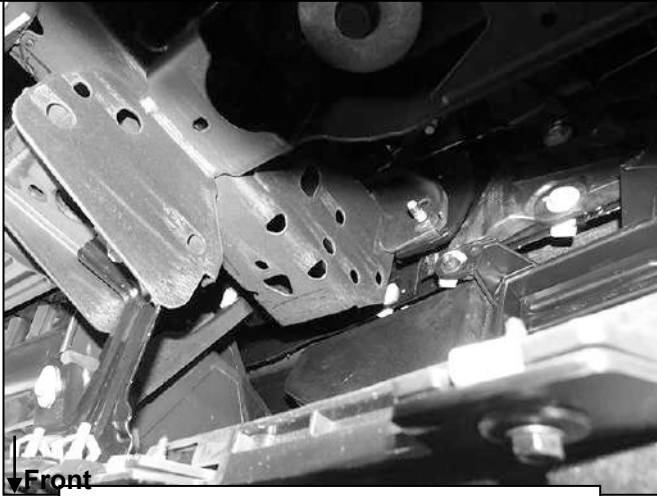

(Fig 5) Passenger/right side of frame and bumper pictured from behind bumper

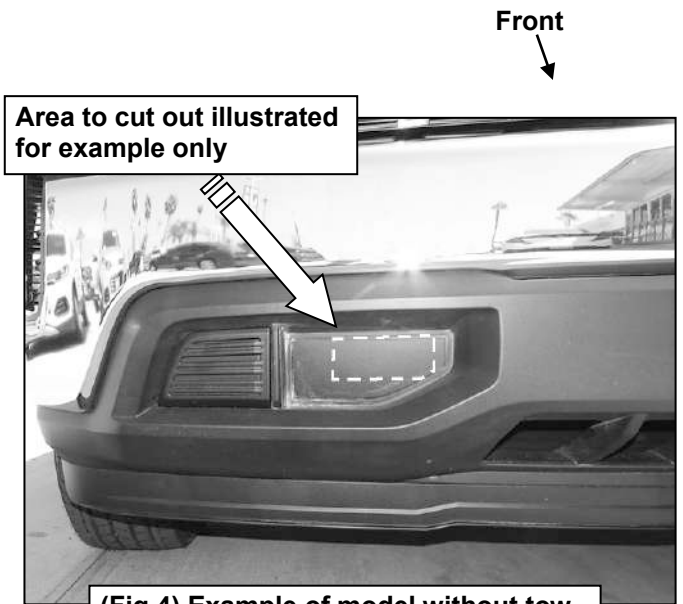

Area to cut out illustrated for example only

(Fig 4) Example of model without tow hooks, passenger/right side pictured

- (3) 8mm Hex Bolts
- (3) 8mm Lock Washers
- (3) 8mm Flat Washers

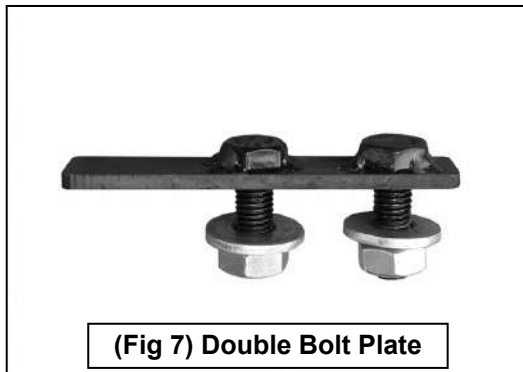

(Fig 7) Double Bolt Plate

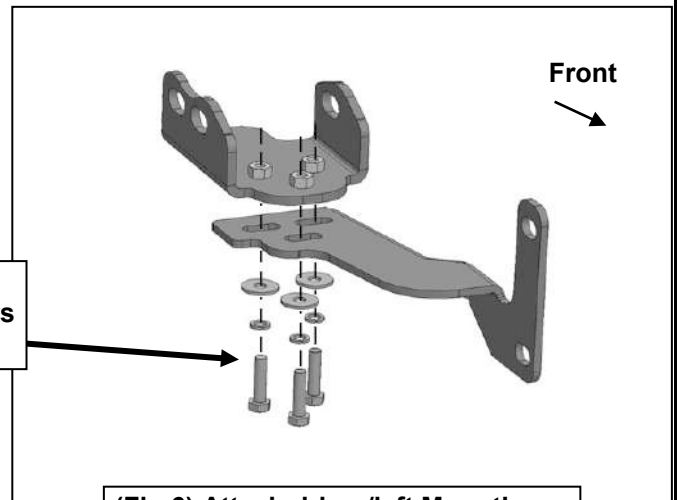

(Fig 6) Attach driver/left Mounting Bracket to bottom of Frame Bracket

## Driver Side Mounting Bracket Installation Pictured

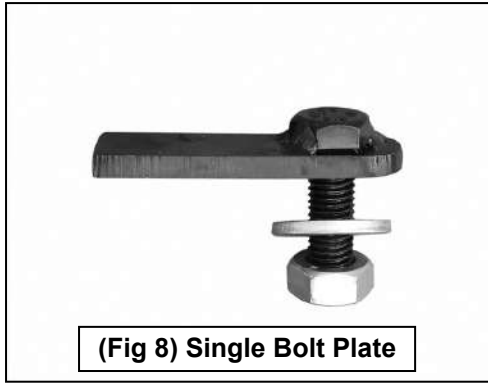

12mm Double Bolt Plate  
(2) 12mm Flat Washers  
(2) 12mm Lock Washers  
(2) 12mm Hex Nuts

12mm Bolt Plate  
12mm Flat Washer  
12mm Lock Washer  
12mm Hex Nut

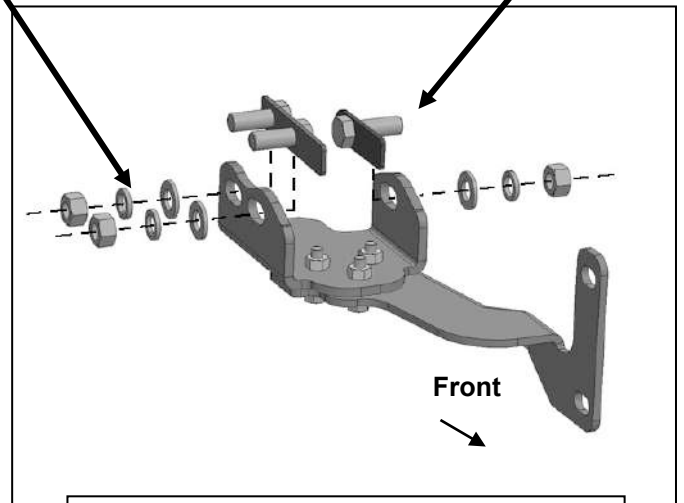

(Fig 9) Attach Driver/left Mounting Bracket assembly to end of frame with Bolt Plates

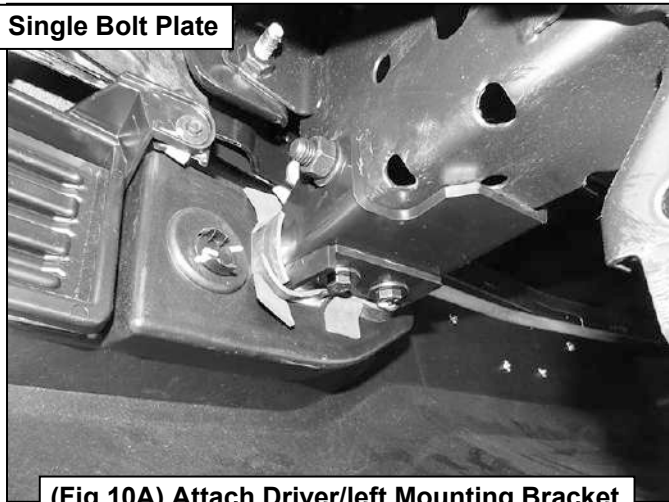

(Fig 10A) Attach Driver/left Mounting Bracket assembly to end of frame with Bolt Plates

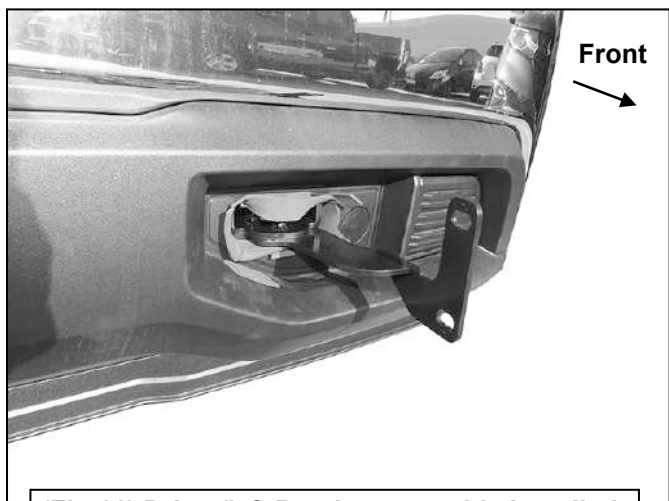

(Fig 11) Driver/left Bracket assembly installed

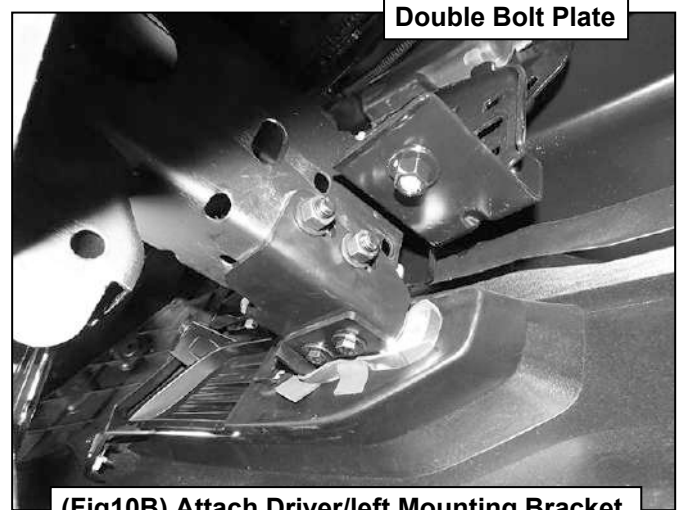

(Fig10B) Attach Driver/left Mounting Bracket assembly to end of frame with Bolt Plates

## Driver Side Mounting Bracket Installation Pictured



(Fig 12) Remove plastic cover from top of grille



(Fig 13) Remove screws attaching grille and carefully pull grille straight out to remove grille

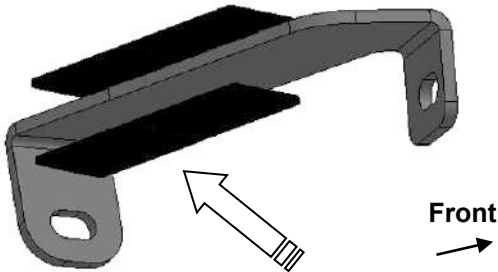

(Fig 14) Apply Foam Tape to underside of Driver/left Top Bracket

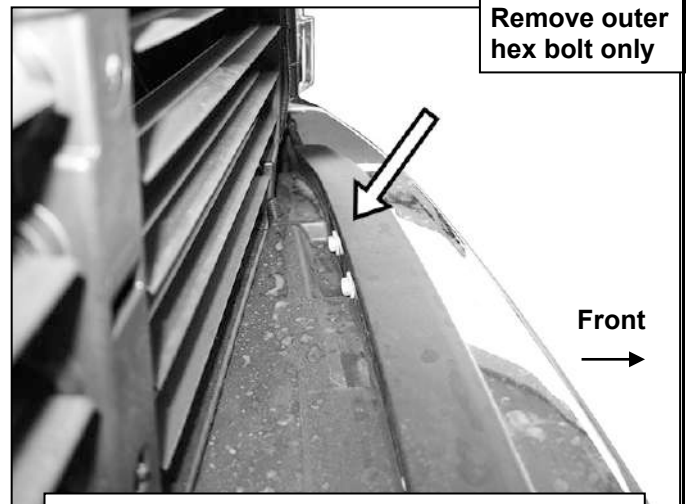

(Fig 15) Driver/left side top mounting location

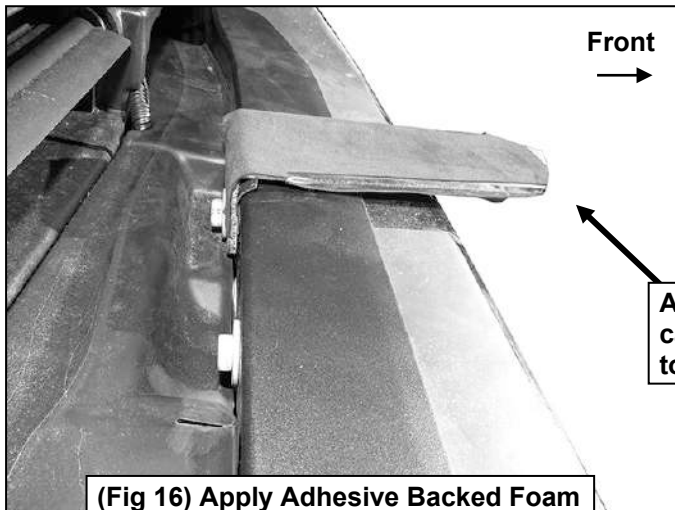

(Fig 16) Apply Adhesive Backed Foam Tape to the underside of Top Bracket

Any remaining tape can be applied to the top of the Bracket

## Driver Side Mounting Bracket Installation Pictured

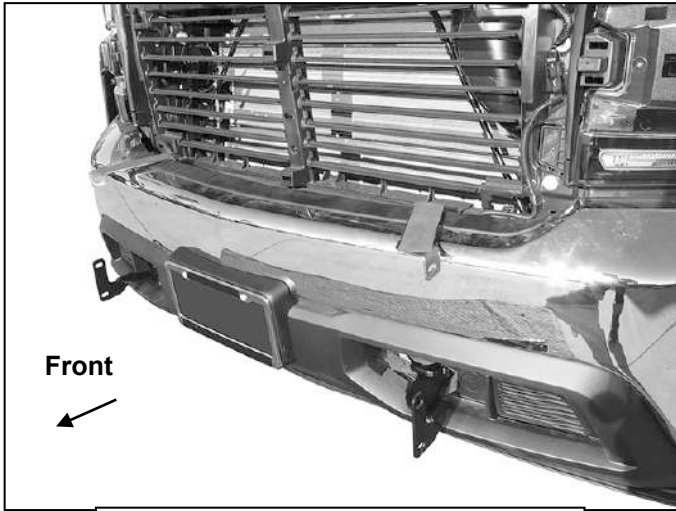

(Fig 17) Mounting Brackets installed

Driver/left  
Top Bracket

- (3) 10mm x 30mm Hex Bolts
- (6) 10mm Flat Washers
- (3) 10mm Lock Washers
- (3) 10mm Hex Nuts

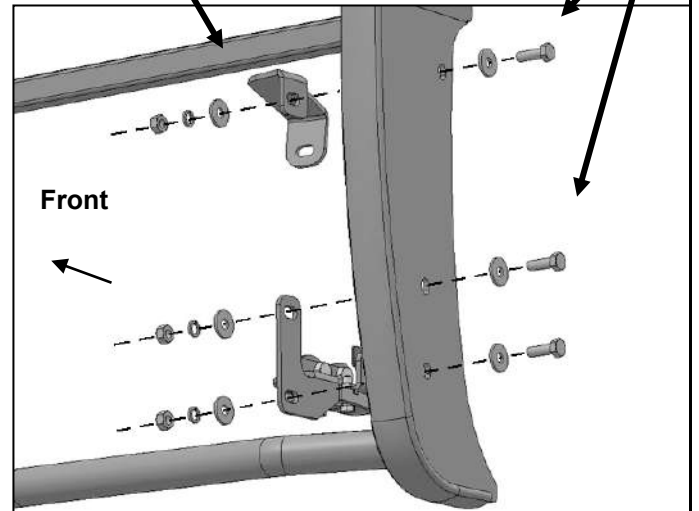

(Fig 18) Attach Grille Guard to Mounting Brackets

Mounting holes for optional  
parking sensor relocation  
kit (available separately)

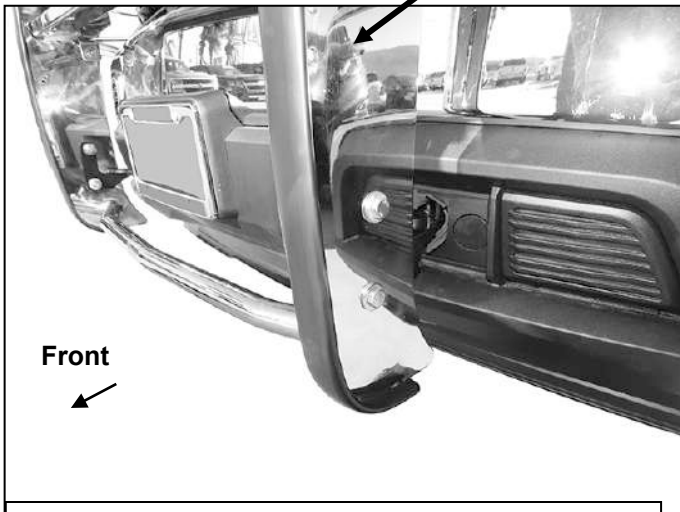

(Fig 19) Attach Grille Guard to Mounting Brackets





No.	Parts Identification
1	Passenger / Right 'Rear' Bracket marked "PR"
2	Driver / Left 'Rear' Bracket marked "DR"
3	Passenger / Right 'Center' Bracket marked "PC"
4	Driver / Left 'Center' Bracket marked "DC"
5	Passenger / Right 'Front' Bracket marked "PF"
6	Driver / Left 'Front' Bracket marked "DF"

**Note:**

- This guide is to identify the parts and not a reference for part count.
- For part count, refer Parts List.
- Product / Bracket image is representative and actual design may vary.

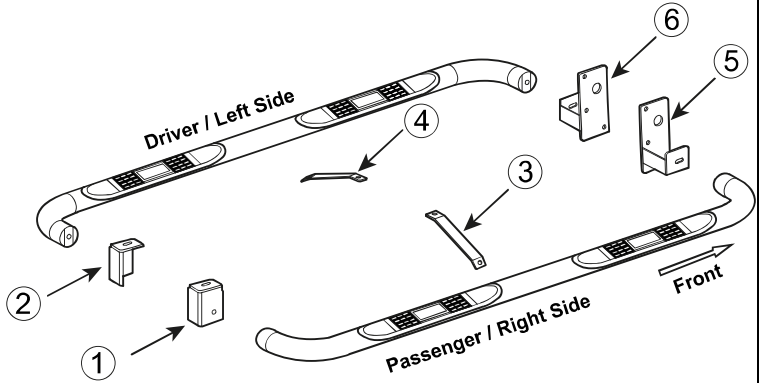

## PRODUCT CARE

- Periodically check the product to ensure all fasteners are tight and components are intact.
- Regular waxing is recommended to protect the finish of the product.
- **Use ONLY Non-Abrasive automotive wax.** Use of any soap, polish or wax that contains an abrasive is detrimental and can scratch the finish leading to corrosion.
- Aluminum polish may be used to polish small scratches and scuffs for **Stainless Steel finish.**
- Mild soap may be used to clean the product for both **Stainless Steel and Black finish.**

## FAQ's

### 1. Hardware's are not of correct size.

*In GMC / Chevrolet truck model 2006 & up, customer needs to reuse the factory body bolts to install the bracket. If your vehicle is not GMC / Chevrolet 2006 & up, ensure that holes are not partially covered with any plastic grommet or rust? If it is, remove the plastic grommet & rust from the thread holes & re-try the installation.*

### 2. Mounting Bracket are not getting Installed properly.

*In some cases Illustration images shown in Installation manual may not be the exactly same as per actual vehicle images ,also if Driver / Passenger side mounting brackets are very identical in the design, suggest referring Parts Identification guide to avoid fitment issue.*

### 3. Products are thumping / rattling after installation.

*Ensure that all required mounting brackets / hardware's are installed & tighten correctly. Suggest using white lithium / regular grease between the metal to metal contact surfaces.*

### 4. Side Bar is not aligning with vehicle / Step Pads are not aligning with vehicle doors.

*Side bar may be interchanged or mounting brackets are not installed at the correct position in the vehicle. Refer Parts identification guide.*

### 5. Missing / Excess Hardware.

*Recheck hardware count as per the part list.*

### 6. Product not installing properly.

*Ensure make model year, cab length and bed size of your vehicle is listed in the application. All installation steps are followed correctly.*

## Check out these other TrailFX Products!!



Keystone Automotive Operations Inc. (KAO) warrants this product to be free of defects in material and workmanship at the time of purchase by the original retail consumer. KAO disclaims any other warranties, express or implied, including the warranty of fitness for a particular purpose or an intended use. If the product is found to be defective, KAO may replace or repair the product at our option, when the product is returned prepaid, with proof of purchase. Alteration to, improper installation, or misuse of this product voids the warranty. KAO's liability is limited to repair or replacement of products found to be defective, and specifically excludes liability for any incidental or consequential loss or damage.