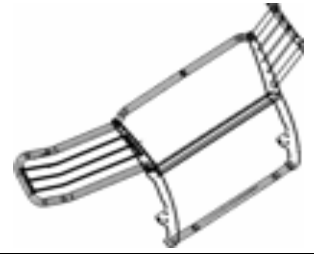


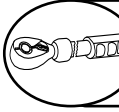


# Grille Guard

## Part No. E0019S /B



Fits: **2007-Current** **Toyota Tundra**  
**2008-2016** **Toyota Sequoia**



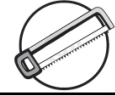
REMOVE CONTENTS FROM BOX. VERIFY ALL PARTS ARE PRESENT.

READ INSTRUCTIONS CAREFULLY BEFORE STARTING INSTALLATION.

DO NOT OVER TORQUE. STANDARD OPERATING LOAD FOR TIGHTEN BODY MOUNT NUTS & BOLTS VARIES FROM 45 TO 65 FOOT POUND.



60-180 min



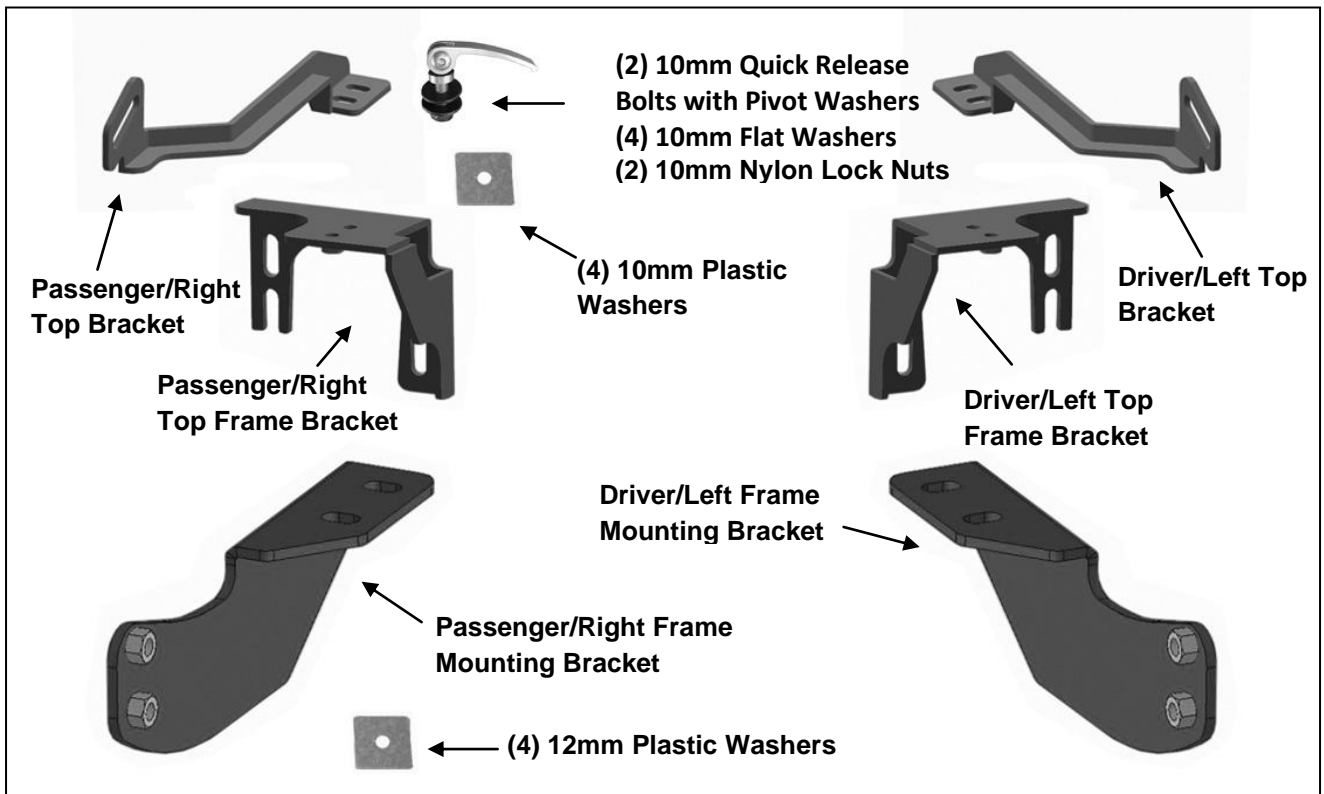
Cutting May be Required



Drilling Not Required

### PARTS LIST:

Qty	Part Description	Qty	Part Description
1	Grille Guard	2	10mm Cam Lever Quick Release Bolts with Special Pivot Washer
1	Driver/left Frame Mounting Bracket	4	10mm x 24mm OD x 2.2mm Flat Washers
1	Passenger/right Frame Mounting Bracket	2	10-1.5mm Nylon Lock Nuts
1	Driver/left Top Frame Bracket	4	8-1.25mm x 25mm Hex Bolts
1	Passenger/right Top Frame Bracket	4	8mm Lock Washers
1	Driver/left Top Bracket	4	8mm x 22mm OD x 2mm Flat Washers
1	Passenger/right Top Bracket	4	12mm Plastic Washers
4	12-1.75mm x 35mm Hex Bolts	4	10mm Plastic Washers
4	12mm x 32mm OD x 3mm Flat Washers	2	600mm x 50mm x 1.0mm Adhesive Foam Strips
4	12mm Lock Washers		

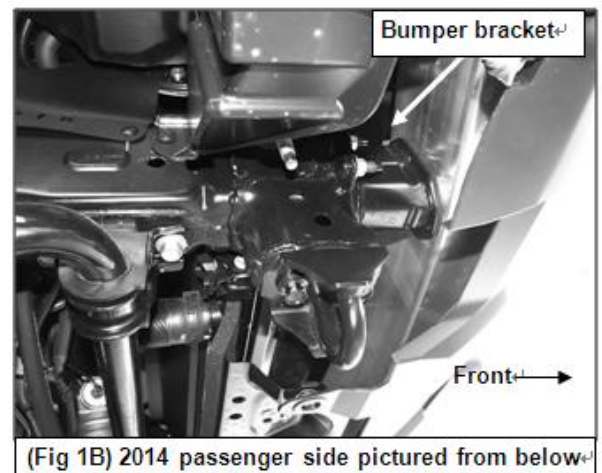
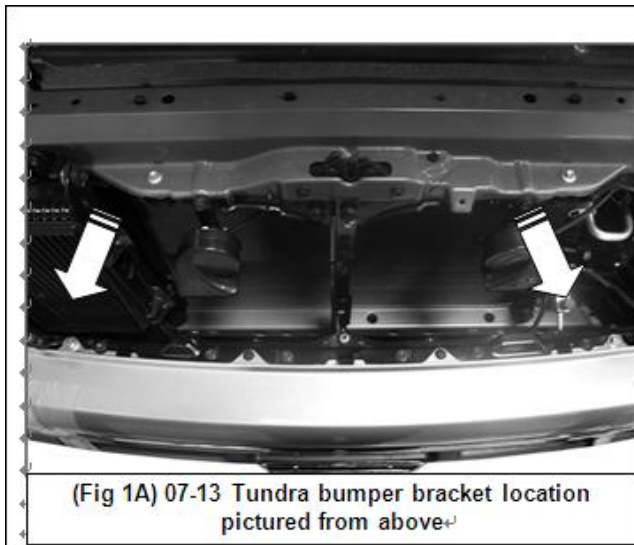


## PROCEDURE:

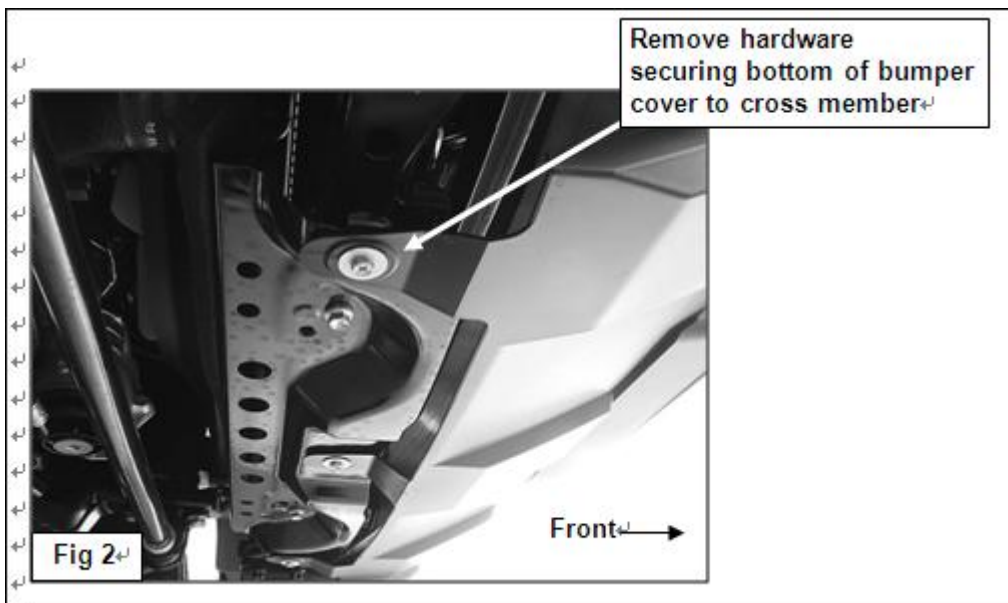
**IMPORTANT:** The Grille Guard is designed to tilt forward to clear the attached grille on 2007-13 Tundra, 08-14 Sequoia models. To tilt the Grille Guard, the Quick Release Bolts on the Top Brackets must be released and the upper bolts on both Mounting Brackets may need to be loosened slightly. Make sure that all hardware is fully tightened after closing the hood. Carefully read Page 8, "Opening and Closing of Hood," before installing the Grille Guard.

1. REMOVE CONTENTS FROM BOX. VERIFY ALL PARTS ARE PRESENT. READ INSTRUCTIONS CAREFULLY BEFORE STARTING INSTALLATION. MAY INTERFERE WITH FRONT MOUNTED SENSORS. NOT RECOMMENDED FOR VEHICLES WITH OPTIONAL "ACTIVE" LASER GUIDED CRUISE CONTROL SYSTEMS. CUTTING MAY BE REQUIRED.
2. Start installation at the front of the vehicle.  
**07-13 Tundra, 08-14 Sequoia models:** Open the hood. Top Brackets can either be installed from above or below front bumper depending on model, accessories and year, **(Figure 1A & 1B)**.

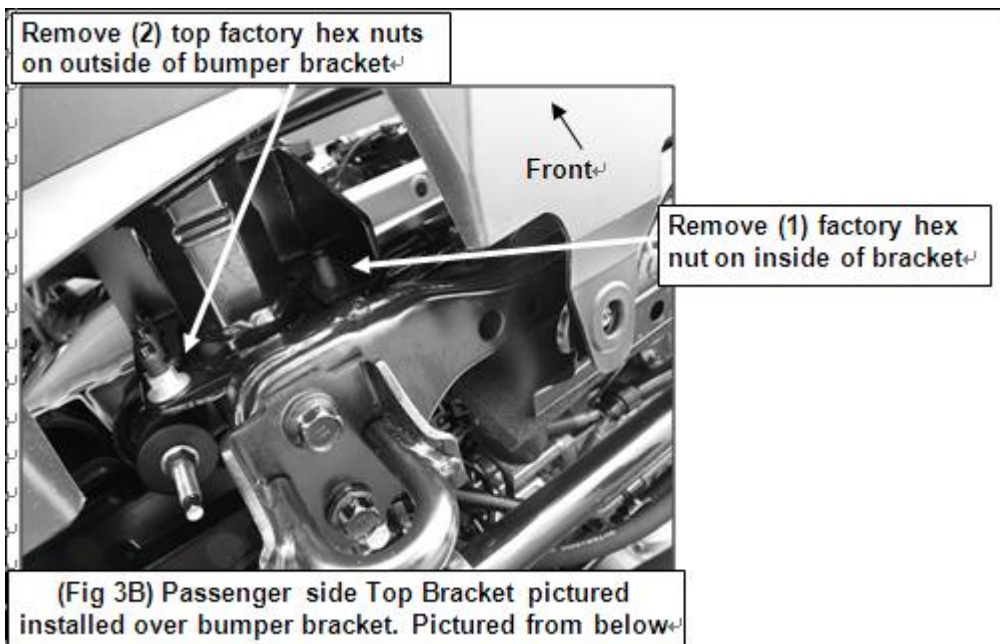
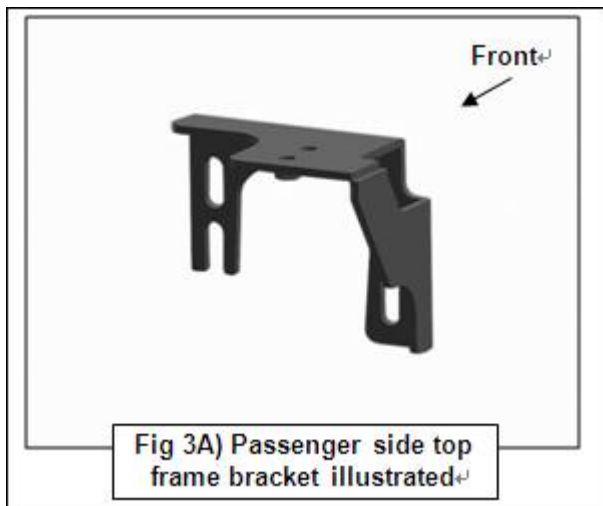
**2014 Tundra models:** Top Brackets must be installed from below front bumper, **(Figure 1B)**.



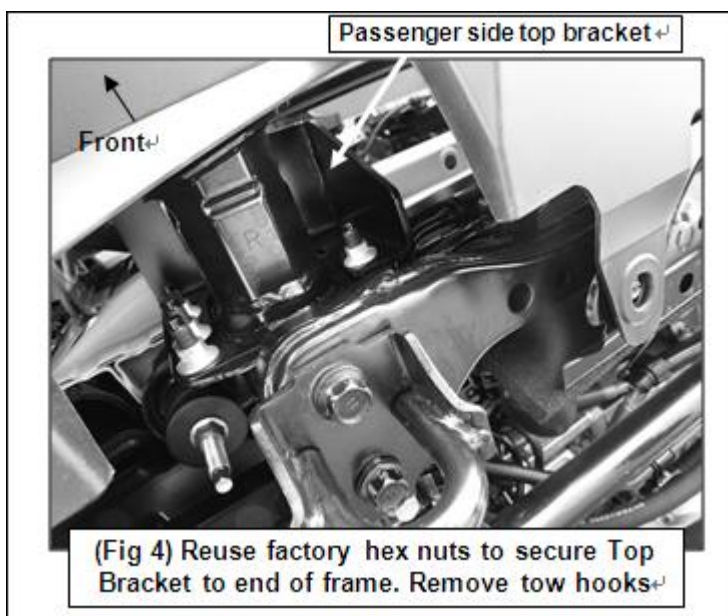
3. Locate the passenger side bumper bracket bolted to the end of the frame through the gap between the front bumper and the radiator or from below the bumper above the tow hook, **(Figure 1B)**. If installing from below, remove the hardware attaching the bumper cover to the cross member to access the end of the frame and bracket, **(Figure 2)**.



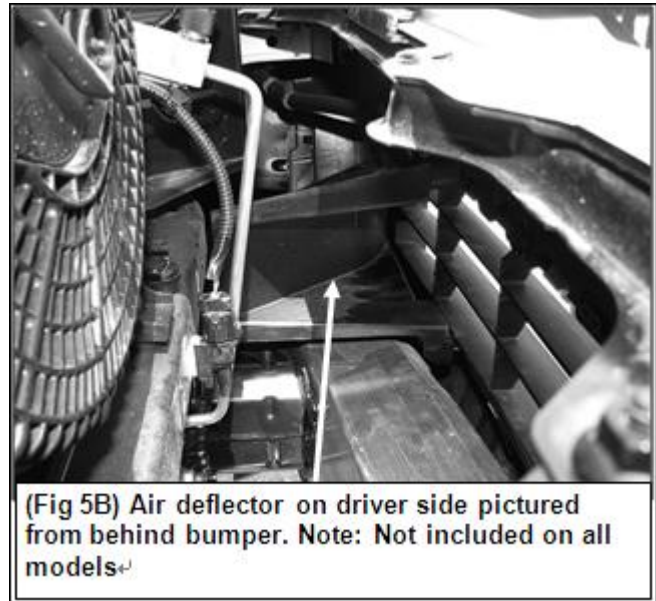
4. Select the passenger side Top Frame Bracket, **(Figure 3A)**. Remove the top (2) factory hex nuts on the outside and the single hex nut on the inside attaching the factory bumper bracket to the end of the frame on the passenger side, **(Figure 3B)**.



5. Slide the U-shaped Bracket over the top of the bumper bracket, down and over the (3) threaded studs, **(Figure 4)**. If installing from below, carefully pull the bottom of the bumper cover outward and slide the Bracket up and in position. Use the factory hex nuts to attach the Top Bracket to the bumper bracket. Snug but do not fully tighten the (3) hex nuts at this time.



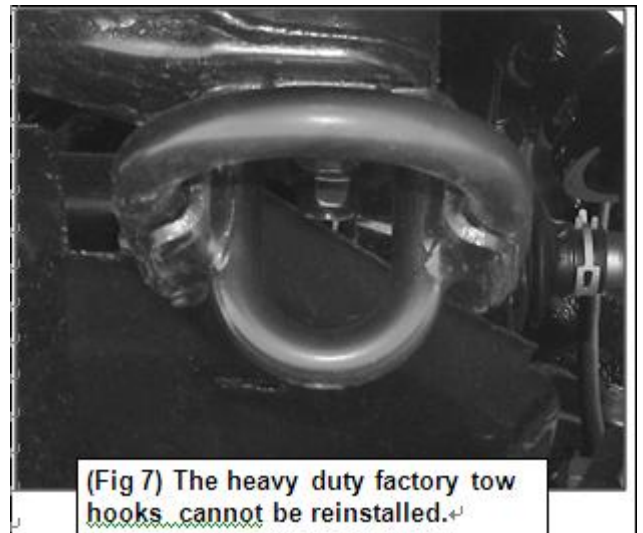
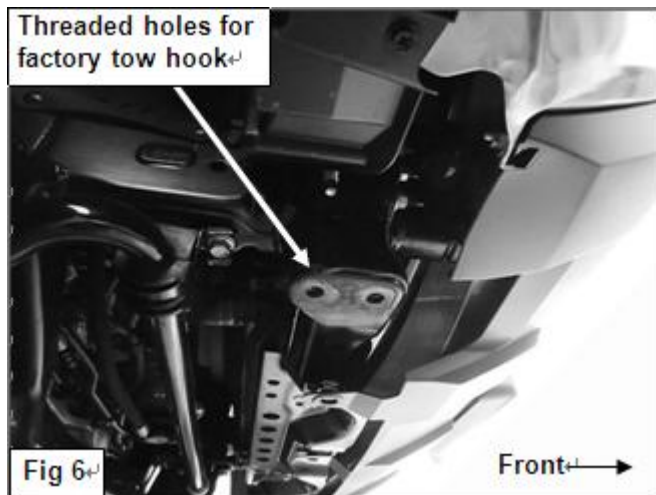
6. Repeat **Steps 3—5** to install the driver side Top Frame Bracket. **IMPORTANT:** Installation will require removal or cutting of plastic air deflector, if equipped, attached to the back of the lower grille, (**Figures 5A & 5B**). **NOTE:** Depending year and model, it may be necessary or easier to remove bumper cover to remove the air deflector from back of lower grille insert.

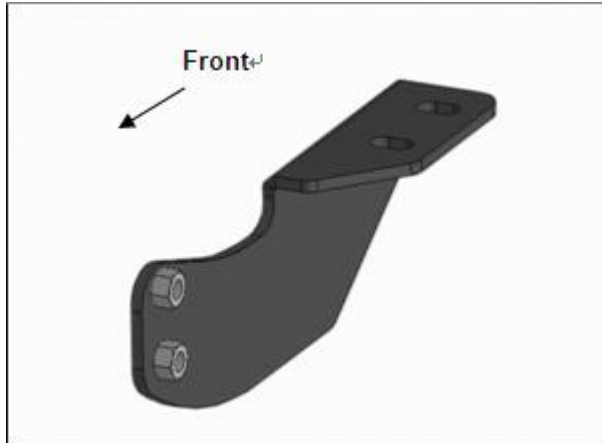


7. From under the front of the vehicle, remove the (2) factory tow hooks and set aside, (**Figures 6 & 7**). Select the passenger side Frame Mounting Bracket, (**Figure 8A**).

**Vehicles with small tow hook:** Line up the holes in the tow hook with the slots in the Bracket. Bolt the tow hook and Bracket to the bottom of the frame using the factory tow hook bolts, (**Figure 8B**).

**Vehicles with large tow hooks:** Bolt the passenger/right side Frame Mounting Bracket directly to the bottom of the frame with the two factory hex bolts. **NOTE:** Large tow hook cannot be reinstalled, (**Figure 7**).



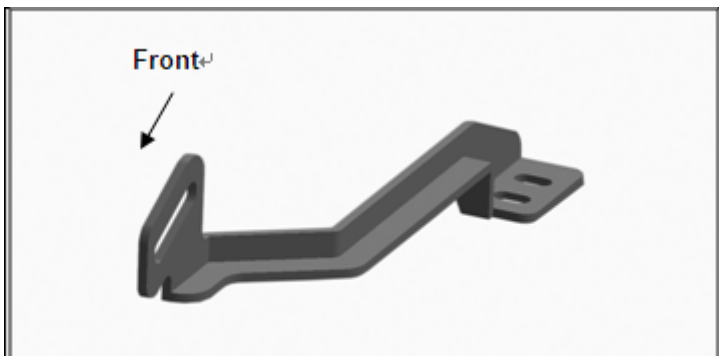


(Fig 8A) Passenger side Frame Mounting Bracket



(Fig 8B) Install Frame Bracket with factory tow hook bolts. Small tow hook pictured

8. Repeat **Step 7** to install the driver/left side Frame Mounting Bracket. Leave hardware loose at this time.
9. Select the passenger side Top Bracket, **(Figure 9A)**. Apply the included Adhesive Backed Foam Tape to the Bracket as needed to protect the grille opening from contact with the Bracket.
10. Slide the Top Bracket in through the opening in the bumper, **(Figure 9B)**. Line up the (2) holes in the Bracket with the previously installed Frame Bracket, **(Figure 10A)**. Bolt the Top Bracket to the top of the Frame Bracket with (2) 8mm Hex Bolts, (2) 8mm Lock Washers and (2) 8mm Flat Washers, **(Figure 10B)**. Leave hardware loose at this time.

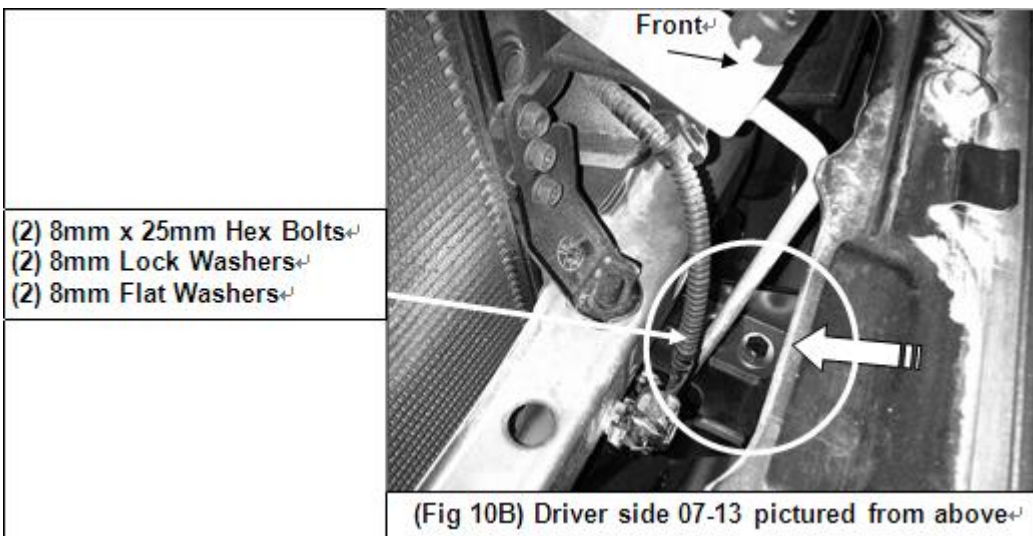
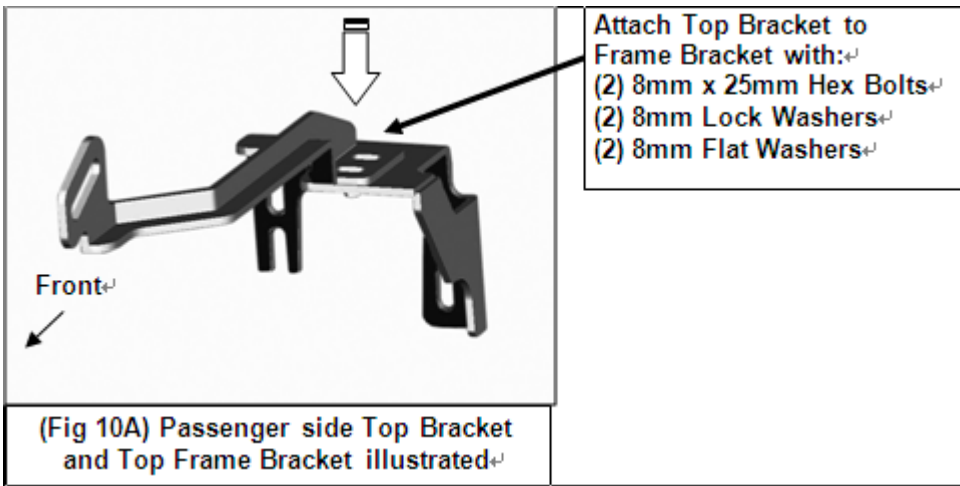


(Fig 9A) Passenger side Top Bracket

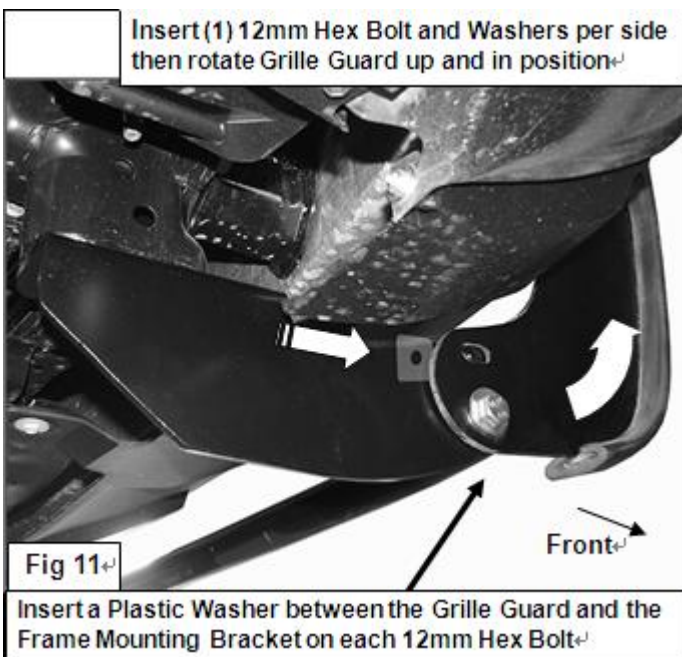


Fig 9B

Insert Top Bracket into opening in bumper (Grille guard pictured installed for reference only do not install at this time)



11. Repeat **Steps 9 & 10** to install the driver side Top Bracket.
12. With assistance, place the Grille Guard face down on a clean surface in front of the vehicle. Position the mounting tabs on the Grille Guard up to the outside of the passenger side Frame Mounting Bracket. Line up the lower hole in the Bracket with the lower hole in the Grille Guard.
13. Insert (1) 12mm Plastic Washer between the Mounting Bracket and the Grille Guard. Line up the Grille Guard, Washer and Bracket and bolt together with the included (1) 12mm x 35mm Hex Bolt, (1) 12mm Lock Washer and (1) 12mm Flat Washer, (**Figure 11**).



14. Repeat **Steps 12—13** to attach the driver side mounting tab to the Bracket. Leave hardware loose.
15. Use the (2) previously installed 12mm Hex Bolts as a hinge. With assistance, carefully rotate the Grille Guard up to the vehicle, (**Figure 11**). Line up the two remaining holes in the Mounting Brackets with the holes in the Grille Guard. Repeat **Steps 13 & 14** to attach the Grille Guard to the Brackets, (**Figure 12**). Snug but do not tighten hardware at this time.

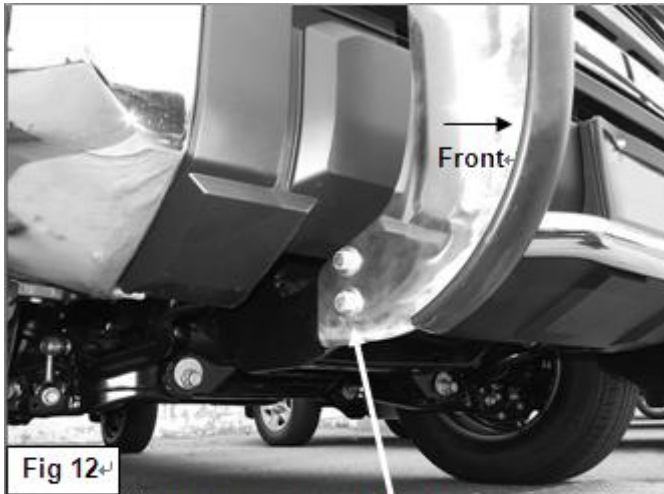


Fig 12

(2) 12mm x 35mm Hex Bolts  
 (2) 12mm Lock Washers  
 (2) 12mm Flat Washers  
 (2) 12mm Plastic Washers  
 (between Grille Guard and Bracket)

16. Next, move to the passenger side Top Bracket installed in **Steps 9 & 10**. Line up the long slot in the Top Bracket with the slot in the Grille Guard upright, (**Figure 13**). Insert (1) 10mm Quick Release Bolt with Pivot Washer and (1) 10mm Flat Washer through the Grille Guard. Thread (1) 10mm Plastic Washer part way onto the threads. Slide the Top Bracket over the Quick Release. Thread (1) 10mm Plastic Washer, (to protect the finish on the Top Bracket), (1) 10mm Flat Washer and (1) 10mm Nylon Lock Nut, (**Figure 13**), onto the Quick Release. Do not fully tighten hardware at this time.

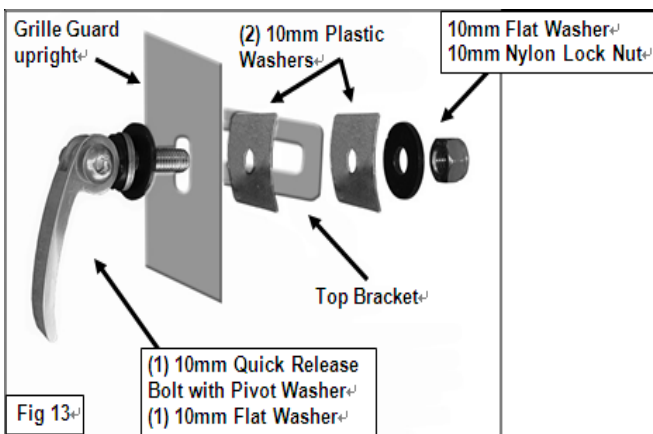
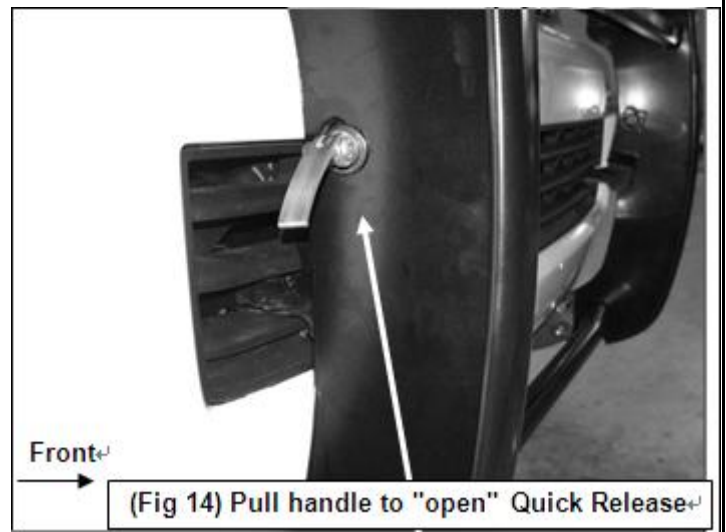


Fig 13

(1) 10mm Quick Release Bolt with Pivot Washer  
 (1) 10mm Flat Washer



(Fig 14) Pull handle to "open" Quick Release

17. Repeat **Step 16** to attach the driver side Top Bracket to the Grille Guard.

18. Release/loosen the levers on the Quick Release Bolts, **(Figure 13)**, and pull the Grille Guard away from the vehicle to the "open" position, **(Figure 15)**. **NOTE:** It may be necessary to slightly loosen the top (2) 12mm Hex Bolts on the Frame Mounting Brackets to move the Grille Guard, **(Figure 16)**. Center and level the Grille Guard and tighten all hardware including the Frame Mounting Brackets.

Pull Grille Guard to the "open" position

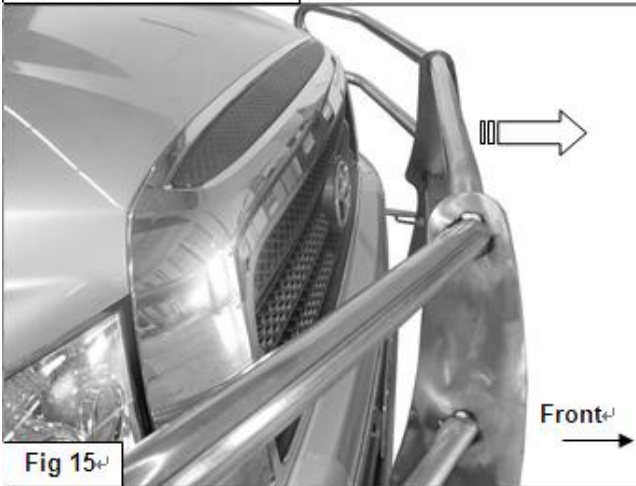


Fig 15

Loosen the top bolts (only if necessary) to open the hood

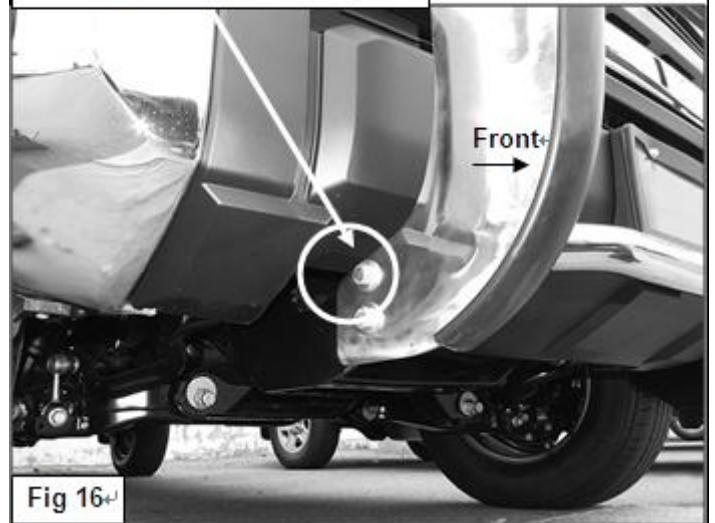


Fig 16

19. Adjust the Quick Release Bolt clamping pressure by loosening or tightening the 10mm Nylon Lock Nuts. See **Steps 23—27** for more information. **NOTE:** Tilt feature only required on 07-13 Tundra and 08-14 Sequoia models. 2014 Tundra model installation can skip to **Step 21**.
20. Slowly close the hood and check for clearance. Release both Quick Release bolts. Push the Grille Guard into the "closed" position. If needed, loosen the upper bolt on each Frame Mounting Bracket, **(Figure 16)**. **WARNING!** Do not completely loosen bolts or damage to the truck or Grille Guard may occur.
21. Push the Grille Guard back towards the vehicle and fully tighten all hardware, **(Figure 17 & 18)**. Reattach the bottom of the bumper cover with the factory hardware, **(Figure 2)**.
22. Do periodic inspections to the installation to make sure that all hardware is secure and tight.

Push Grille Guard back to the "closed" position

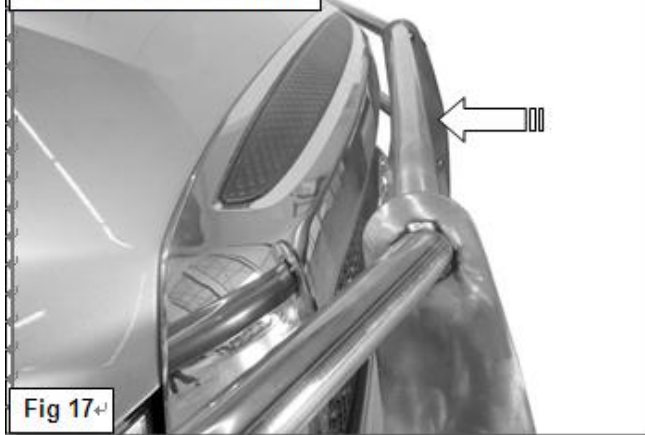


Fig 17

Quick Release in "closed" position



Fig 18



### Opening and closing the hood-required for 2007-13 models only

23. Lift the levers on the Quick Release bolt to release the clamping pressure, **(Figure 14)**. Pull the Grille Guard out and away from the vehicle to the "open" position, **(Figure 15)**. **NOTE:** If the Grille Guard does not pivot to "open" position, **slightly loosen the 12mm upper hex bolt on each Mounting Bracket, (Figure 16)**. **WARNING!** Do not completely loosen bolts or damage to the truck may occur.
24. Carefully pull on the Grille Guard until it is fully extended away from the vehicle, **(Figure 15)**.
25. Pull the hood release and slowly open the hood.
26. **IMPORTANT!** Before closing the hood, always make sure that the Grille Guard is in the full open position and away from the vehicle. Pull on the Grille Guard to verify that it is fully extended away from the vehicle and slowly close the hood, **(Figure 15)**.
27. Once the hood is completely closed, push the Grille Guard back to its "closed," upright position and tighten all hardware on the Grille Guard, **(Figure 17)**. Push down on the Quick Release lever to tighten, **(Figure 18)**. No tools are required to close the Quick Release levers. It will require some effort to open and close by hand when properly adjusted. Loosen or tighten the 10mm Nylon Lock Nut on the Quick Release bolt to adjust the clamping pressure.
28. Do periodic inspections to the installation to make sure that all hardware is secure and tight.

