



Bed Rail



Part Numbers

1612118991	1620210941	D0008S	1630311971	1630331921	D0008B	1699124923
1612114881	1630310041	D0006S	1630350081	1650510071	D0006B	1630378XX1
1610122881	1612118993	D0007S	1630350991	1650500071	D0007B	1630378XX3
1650510073	1630350083	D0010B	1630310043	1612114883	1650500073	1699124921
D0009S	1620210943	D0010S	1630311973	D0009B	1630350993	1630331923
1610122883						

Fits: Bolt-On Bed Rail



60-180 min



CUTTING NOT REQUIRED



DRILLING NOT REQUIRED



REMOVE CONTENTS FROM BOX. VERIFY ALL PARTS ARE PRESENT.



READ INSTRUCTIONS CAREFULLY BEFORE STARTING INSTALLATION.

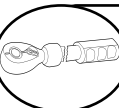

DO NOT OVER TORQUE. STANDARD OPERATING LOAD FOR TIGHTEN BODY MOUNT NUTS & BOLTS VARIES FROM 45 TO 65 FOOT POUND.

PARTS LIST:

Qty	Part Description	Qty	Part Description
4	80mm Rectangular Threaded Brackets	1	Allen Wrench
4	50mm Parallelogram Threaded Bracket	4	10-1.50mm x 50mm Allen Head Bolts
		4	10mm ID x 20mm OD x 1.5mm Stainless Steel Flat Washers

INSTALLATION PROCEDURE

- VERIFY BEDRAIL IS CORRECT LENGTH TO COVER STAKE POCKETS BEFORE CUTTING!**
- On models with factory equipped plastic bedside covers, determine if there is a separate removable cover over each of the stake pockets.
 - On vehicles with removable covers:** Remove the small plastic cover over each stake pocket, (Figure 1).

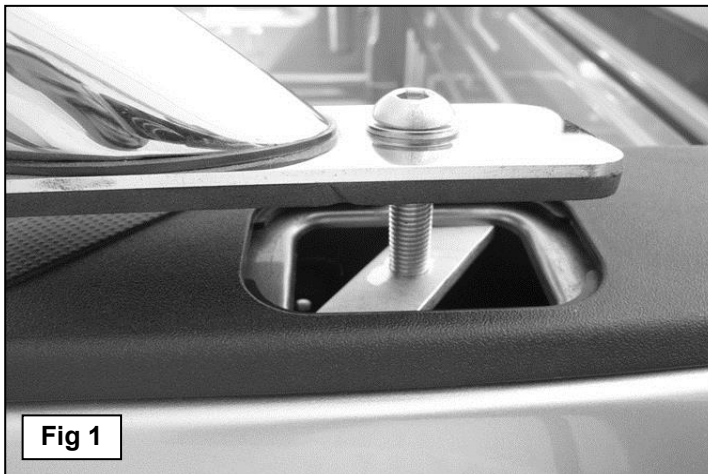

Fig 1

Remove cover if equipped. Note, on some vehicles, size of opening in cover may be larger than actual stake pocket

- b. **On vehicles without removable covers:** Locate the center of the stake pocket. Carefully cut or drill a small opening in the plastic cover in the center of the stake pocket. **WARNING**, verify exact location of stake pocket before drilling/cutting plastic cover or damage to top of bedside may result. Gradually enlarge the opening to the size of the stake pocket only, (**Figure 2**). **IMPORTANT, DO NOT** cut along factory lines molded into the plastic cover as these lines may not represent the correct location or size of the stake pocket and may be larger than the actual stake pocket opening.

Dotted line represents approximate size of stake pocket hidden under plastic cover

Determine location of center of stake pocket before cutting cover. Start with a small hole and gradually enlarge the hole to the size of the stake pocket only. Do not follow lines molded into cover!

Note that size of stake pocket may be smaller than line molded into cover by factory. Determine location of stake pocket before cutting cover. Picture for example only, actual vehicle may be different.

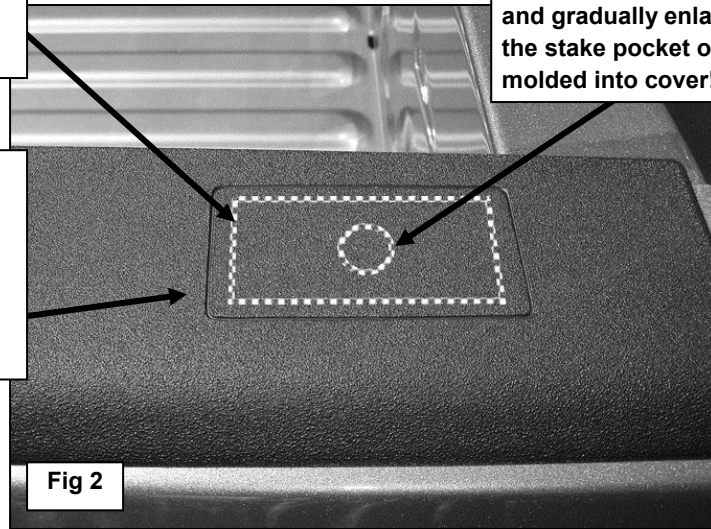
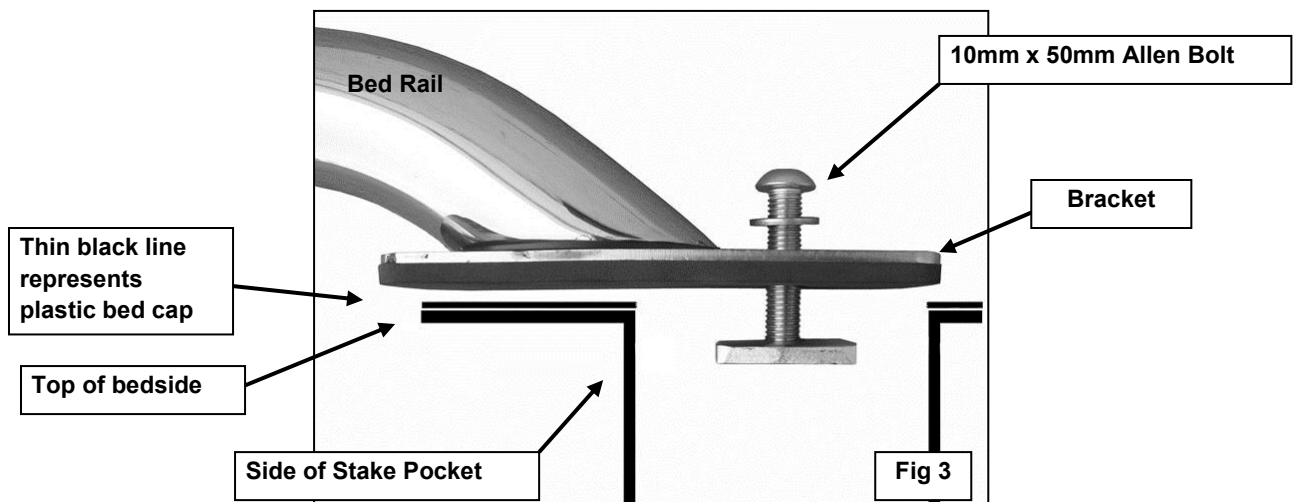
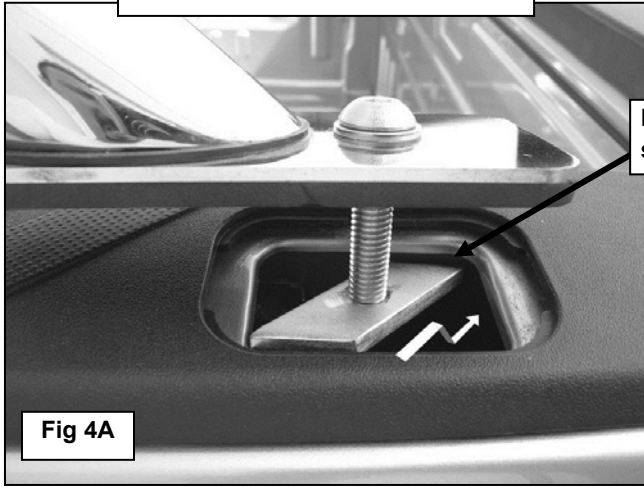

Fig 2

3. Attach (1) 10mm Bolt, (1) 10mm Flat Washer, and (1) Threaded Bracket to each end of Bed Rail as shown in **Figure 3**. **NOTE:** Depending upon your vehicle, use the correct size Threaded Bracket. For small stake pockets, use the parallelogram-shaped bracket, (**Figure 4A**) and for larger stake pockets use the rectangular-shaped bracket, (**Figure 4B**). Leave hardware loose.
4. Position the Bed Rail onto the top of the bed. Attach the front of the Bed Rail by tilting the Bolt until one side of the Bracket engages, (**Figure 4A & 4B**). Once you engage one side of Bracket, slide Bracket into stake pocket until opposite side of Bracket engages on the opposite side of stake pocket. Before tightening, engage the rear end of Bed Rail. Repeat this step to engage rear end of Bed Rail.



Small Stake Pocket Pictured



Engage one side first

Oversized Stake Pocket Pictured

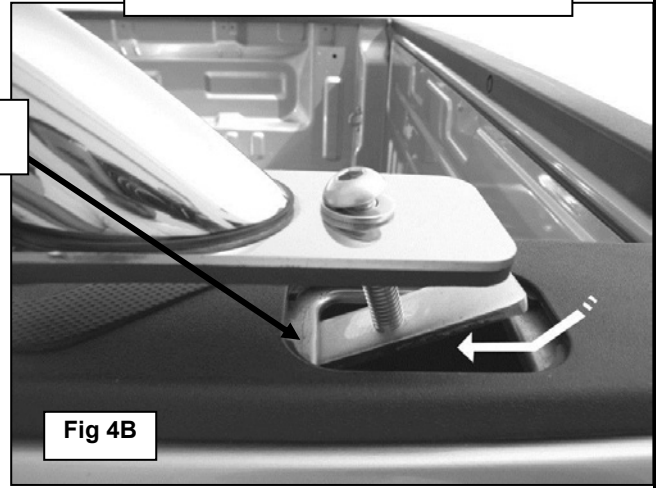

5. To tighten the Brackets, pull up on one end of the Bed Rail and make sure the Bracket is engaged and centered. Keep pulling up on the Bed Rail to prevent Bracket from moving/rotating while tightening the Mounting Bolt. Tighten the front until it is snug but do not fully tighten at this time, **(Figure 5A & 5B)**. Repeat this Step to install the rear of the Bedrail. Once properly centered and aligned, fully tighten both Mounting Bolts.

Small Stake Pocket Pictured

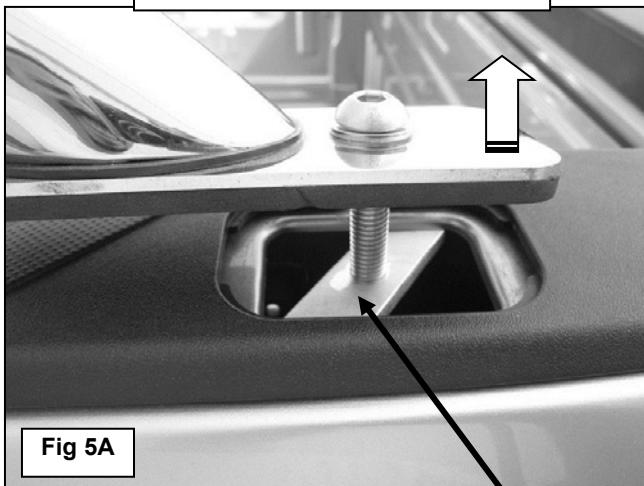

Oversized Stake Pocket Pictured

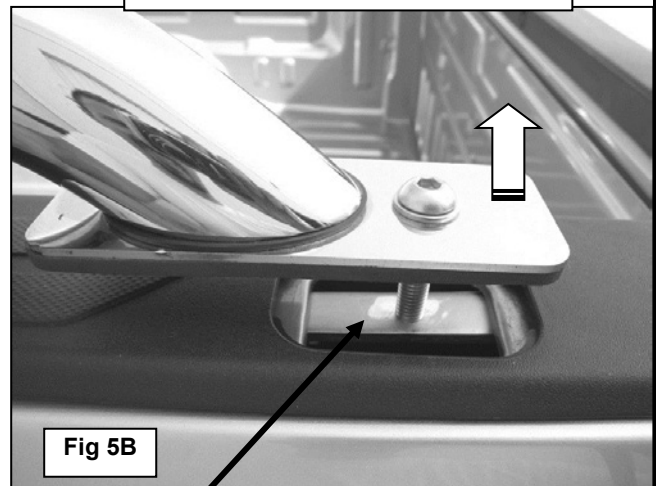

Pull up on Bedrail as you tighten the mounting screw to hold the threaded plate in place against inside of stake pocket

6. Repeat steps 2 – 5 for opposite side Bed Rail installation.

Complete Installation



PARTS IDENTIFICATION GUIDE

Driver Side tube packed using "Green" color foam sheet. Passenger Side tube packed using "White" color foam sheet

No.	Parts Identification
1	Passenger / Right 'Rear' Bracket marked "PR"
2	Driver / Left 'Rear' Bracket marked "DR"
3	Passenger / Right 'Center' Bracket marked "PC"
4	Driver / Left 'Center' Bracket marked "DC"
5	Passenger / Right 'Front' Bracket marked "PF"
6	Driver / Left 'Front' Bracket marked "DF"

Note:

- This guide is to identify the parts and not a reference for part count.
- For part count, refer Parts List.
- Product / Bracket image is representative and actual design may vary.

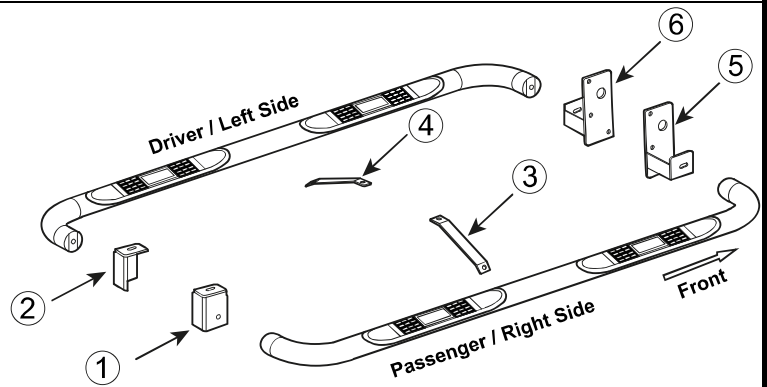

PRODUCT CARE

- Periodically check the product to ensure all fasteners are tight and components are intact.
- Regular waxing is recommended to protect the finish of the product.
- **Use ONLY Non-Abrasive automotive wax.** Use of any soap, polish or wax that contains an abrasive is detrimental and can scratch the finish leading to corrosion.
- Aluminum polish may be used to polish small scratches and scuffs for **Stainless Steel finish.**
- Mild soap may be used to clean the product for both **Stainless Steel and Black finish.**

FAQ's

1. Hardware's are not of correct size.

In GMC / Chevrolet truck model 2006 & up, customer needs to reuse the factory body bolts to install the bracket. If your vehicle is not GMC / Chevrolet 2006 & up, ensure that holes are not partially covered with any plastic grommet or rust? If it is, remove the plastic grommet & rust from the thread holes & re-try the installation.

2. Mounting Bracket are not getting Installed properly.

In some cases Illustration images shown in Installation manual may not be the exactly same as per actual vehicle images ,also if Driver / Passenger side mounting brackets are very identical in the design, suggest referring Parts Identification guide to avoid fitment issue.

3. Products are thumping / rattling after installation.

Ensure that all required mounting brackets / hardware's are installed & tighten correctly. Suggest using white lithium / regular grease between the metal to metal contact surfaces.

4. Side Bar is not aligning with vehicle / Step Pads are not aligning with vehicle doors.

Side bar may be interchanged or mounting brackets are not installed at the correct position in the vehicle. Refer Parts identification guide.

5. Missing / Excess Hardware.

Recheck hardware count as per the part list.

6. Product not installing properly.

Ensure make model year, cab length and bed size of your vehicle is listed in the application. All installation steps are followed correctly.