

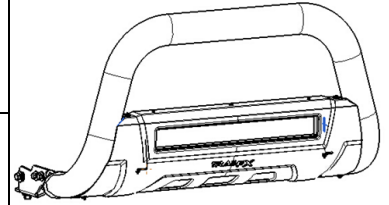

# 3.5" Oval Bull Bar

## Part No. B1604S/B



Fits: 2015-2016

Chevrolet Colorado / GMC Canyon



ASSISTANCE IS RECOMMENDED.



60-180 min

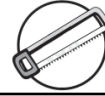

Cutting Required



Drilling Not Required



REMOVE CONTENTS FROM BOX. VERIFY ALL PARTS ARE PRESENT.



READ INSTRUCTIONS CAREFULLY BEFORE STARTING INSTALLATION.

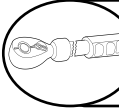

DO NOT OVER TORQUE. STANDARD OPERATING LOAD FOR TIGHTEN BODY MOUNT NUTS & BOLTS VARIES FROM 45 TO 65 FOOT POUND.

### PARTS LIST:

Qty	Part Description	Qty	Part Description
1	3.5in Oval Bull Bar Assembly	4	10-1.5mm x 30mm Hex Bolts
1	Driver/left Mounting Bracket	8	10mm x 20mm OD x 2mm Flat Washers
1	Passenger/right Mounting Bracket	4	10mm Lock Washers
2	Bull Bar Mounting Brackets	4	10-1.5mm Hex Nuts
2	12-1.75mm x 100mm Double Bole Plates	4	8-1.25mm x 35mm Hex Bolts
4	12mm x 24mm OD x 2.5mm Flat Washers	4	8mm x 24mm x 2mm Flat Washers
4	12-1.75mm Nylon Lock Nuts	4	8mm Lock Washers

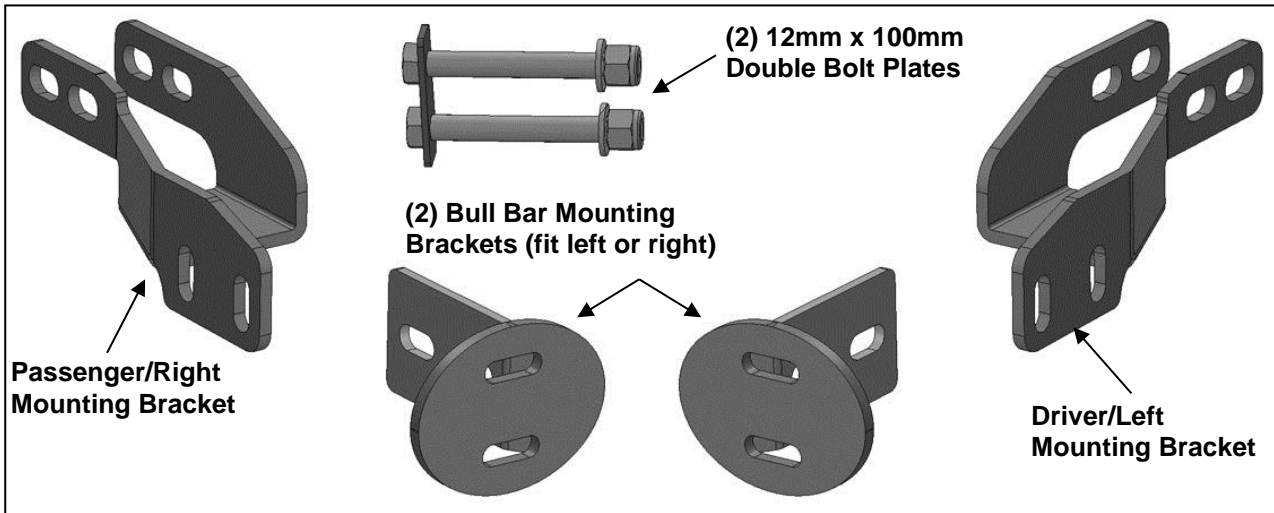

## INSTALLATION PROCEDURE:

**CUTTING MAY BE REQUIRED. INSTALLATION MAY INTERFERE WITH FRONT MOUNTED SENSORS.**

**NOTE:** It may be necessary to remove/relocate front license plate and license plate bracket. It is not required, but strongly recommended. If local/state law requires a front license plate, license plate relocation kit is available.

1. Start installation from under the front of the vehicle. Remove the plastic splash guard from below-behind bumper, **(Figure 1)**. Determine if the vehicle is equipped with tow hooks. **IMPORTANT:** Tow hooks cannot be reinstalled with the Bull Bar. Also, it may be necessary to temporarily remove the factory skid plate, (if equipped), to access the mounting locations.

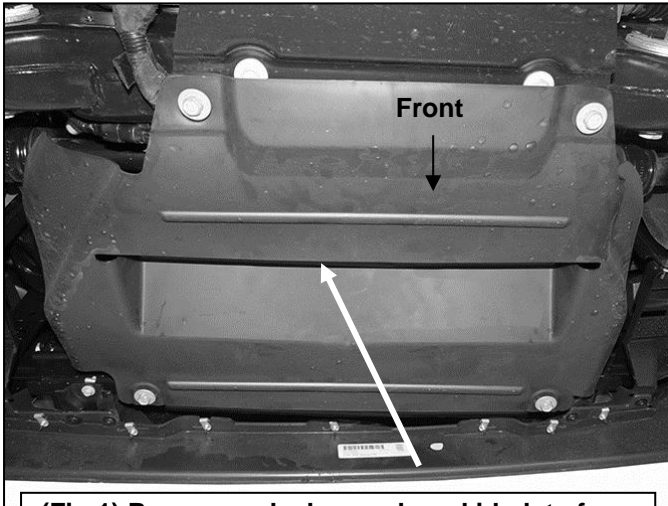

**(Fig 1) Remove splash guard or skid plate from bottom of engine behind bumper if necessary**

### Tow Hook equipped vehicles:

- a. Remove the driver side tow hook and hardware from the end of the frame channel, **(Figures 2 & 3)**. Remove the seal between the opening in the bumper and the tow hook, **(Figures 2 & 4)**.



**(Fig 2) Passenger side with tow hook**

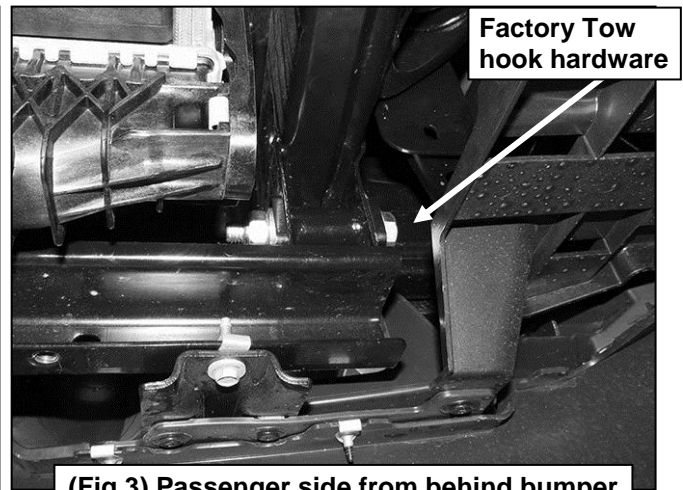

**(Fig 3) Passenger side from behind bumper**



**(Fig 4) Driver side after tow hook removed**

b. Repeat to remove the passenger side tow hook.

c. Proceed to **Step 2**.

**Vehicles without tow hooks:**

a. Cut out the indented area in both sides of the plastic bumper to clear the Brackets as pictured, (**Figures 5 & 6**). **IMPORTANT:** Make several small cuts for best fit. **OPTION:** Cut around the Bracket as indicated, (**Figure 6**), or cut along the rectangular cut line molded into the pocket, (**Figure 4**).

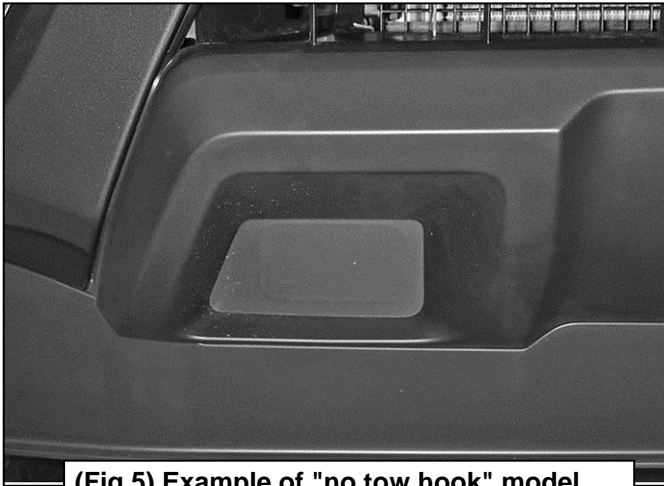

(Fig 5) Example of "no tow hook" model

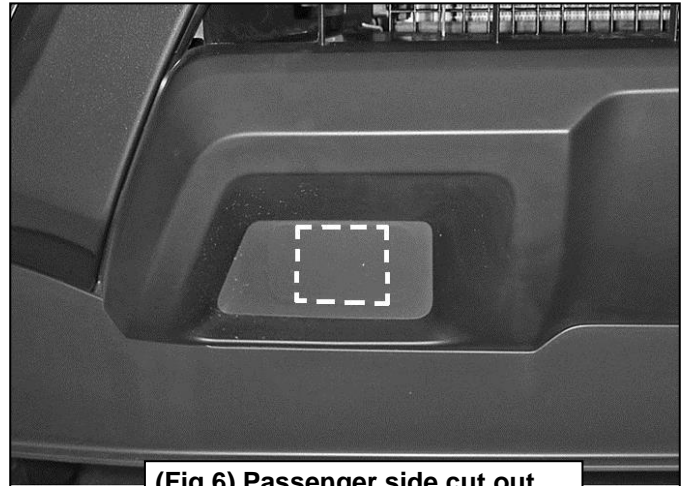

(Fig 6) Passenger side cut out illustrated for reference only

2. Select the driver side Mounting Bracket, (**Figure 8**). Insert the Bracket through the opening in the bumper and up to the tow hook mounting holes, (**Figures 7 & 9**). Trim the plastic as required for clearance.

Mounting holes in end of frame for tow hook

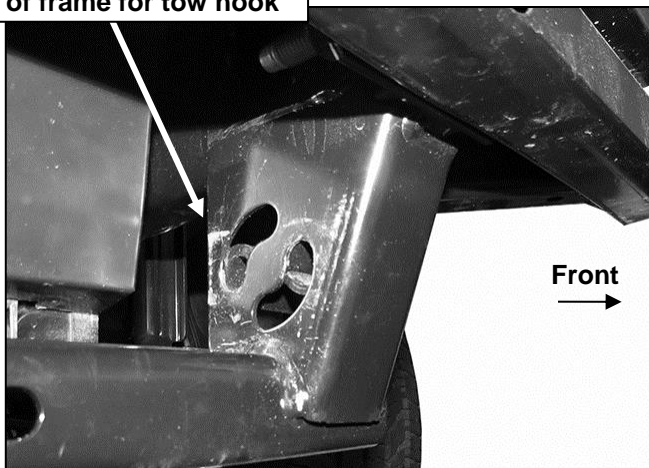

(Fig 7) Driver side pictured without bumper for instruction purposes only. Do not remove bumper

12mm Double Bolt Plate  
(4) 12mm Flat Washers  
(2) 12mm Nylon Lock Nuts

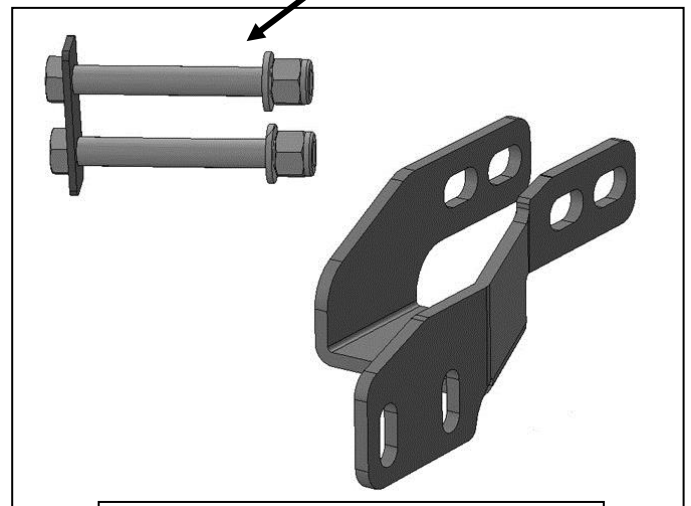

(Fig 8) Driver/left Mounting Bracket and 12mm Double Bolt Plate

3. Line up the (2) holes in the Bracket with the (2) holes in the frame for the tow hook, (**Figure 7**). Select the 12mm Double Bolt Plate, (**Figure 8**). Insert the Bolt Plate through the Bracket and the (2) holes through the frame, (**Figures 7 & 9**). Secure with (2) 12mm Flat Washers and (2) 12mm Nylon Lock Nuts. Do not fully tighten hardware at this time.

12mm Double Bolt Plate  
(4) 12mm Flat Washers  
(2) 12mm Nylon Lock Nuts

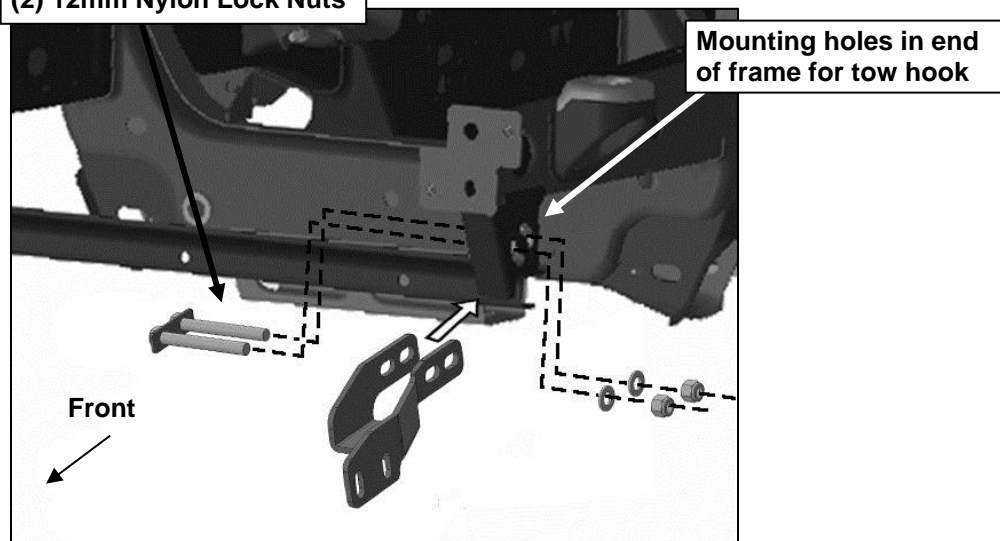

(Fig 9) Installation illustrated without bumper cover for instruction purposes only. Do not remove bumper cover.

- Repeat **Steps 2 & 3** to install the passenger side Mounting Bracket.
- Next, select (1) Bull Bar Bracket, (**Figure 10**). Attach the Bracket to the end of the Bull Bar with (2) 8mm Hex Bolts, (2) 8mm Lock washers and (2) 8mm Flat Washers, (**Figure 11**). Do not fully tighten hardware at this time. Repeat to attach the remaining Bull Bar Bracket to the passenger/right side.

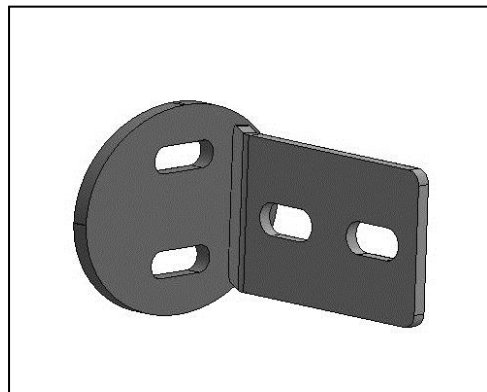

(Fig 10) Left or right Bull Bar Bracket

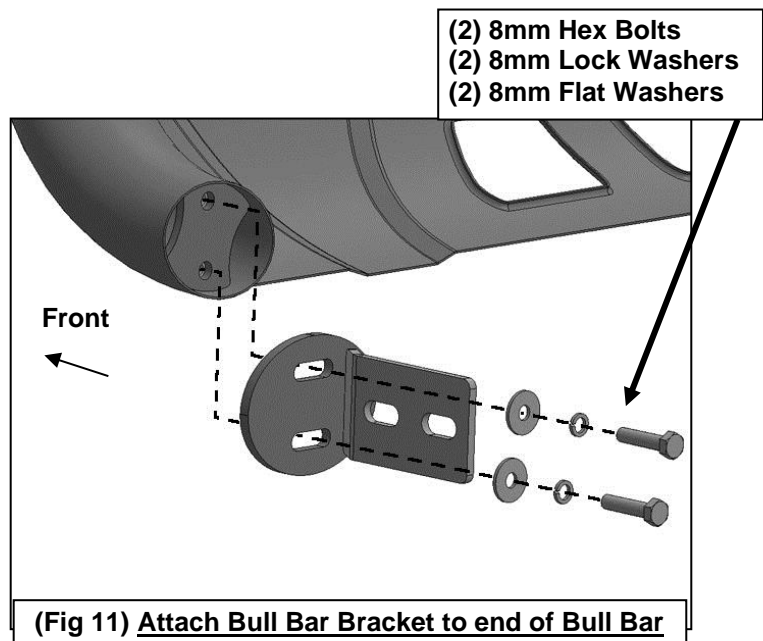

- With assistance, hold the Bull Bar with Brackets up in position on the inside of the Mounting Brackets. Attach the Bull Bar to the Brackets with (4) 10mm x 30mm Hex Bolts, (8) 10mm Flat Washers and (4) 10mm Nylon Lock Nuts, (**Figure 12**). Do not tighten hardware at this time.

- (2) 10mm Hex Bolts
- (4) 10mm Flat Washers
- (2) 10mm Lock Washers
- (2) 10mm Hex Nuts

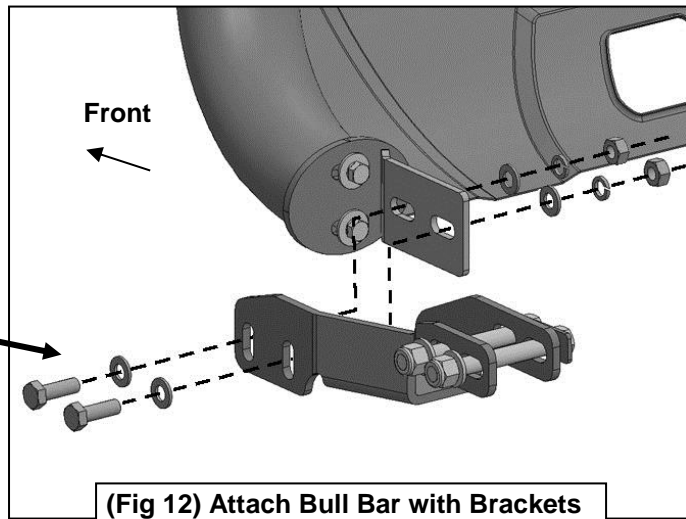

(Fig 12) Attach Bull Bar with Brackets to inside of Mounting Brackets

7. Check the Bull Bar alignment with the vehicle and for clearance between the Bull Bar and the bumper. Adjust as required then fully tighten all hardware.
8. Reinstall the plastic splash guard or skid plate removed in **Step 1, (Figure 1)**.

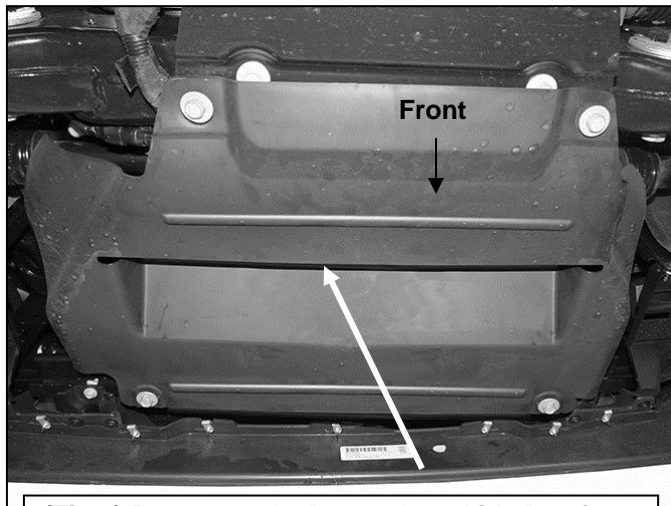

(Fig 1) Remove splash guard or skid plate from bottom of engine behind bumper if necessary

9. Do periodic inspections to the installation to make sure that all hardware is secure and tight.

## PRODUCT CARE

- Periodically check the product to ensure all fasteners are tight and components are intact.
- Regular waxing is recommended to protect the finish of the product.
- **Use ONLY Non-Abrasive automotive wax.** Use of any soap, polish or wax that contains an abrasive is detrimental and can scratch the finish leading to corrosion.
- Aluminum polish may be used to polish small scratches and scuffs for **Stainless Steel finish.**
- Mild soap may be used to clean the product for both **Stainless Steel and Black finish.**

## FAQ's

**1. Hardware's are not of correct size.**

*In GMC / Chevrolet truck model 2006 & up, customer needs to reuse the factory body bolts to install the bracket. If your vehicle is not GMC / Chevrolet 2006 & up, ensure that holes are not partially covered with any plastic grommet or rust? If it is, remove the plastic grommet & rust from the thread holes & re-try the installation.*

**2. Mounting Bracket are not getting Installed properly.**

*In some cases Illustration images shown in Installation manual may not be the exactly same as per actual vehicle images ,also if Driver / Passenger side mounting brackets are very identical in the design, suggest referring Parts Identification guide to avoid fitment issue.*

**3. Products are thumping / rattling after installation.**

*Ensure that all required mounting brackets / hardware's are installed & tighten correctly. Suggest using white lithium / regular grease between the metal to metal contact surfaces.*

**4. Side Bar is not aligning with vehicle / Step Pads are not aligning with vehicle doors.**

*Side bar may be interchanged or mounting brackets are not installed at the correct position in the vehicle. Refer Parts identification guide.*

**5. Missing / Excess Hardware.**

*Recheck hardware count as per the part list.*

**6. Product not installing properly.**

*Ensure make model year, cab length and bed size of your vehicle is listed in the application. All installation steps are followed correctly.*

## Check out these other TrailFX Products!!



**BULL BAR**



**GRILLE GUARDS**



**BED RAILS**

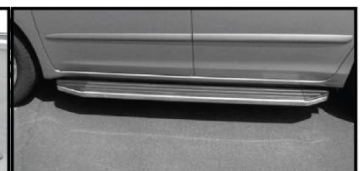

**RUNNING BOARDS**

Keystone Automotive Operations Inc. (KAO) warrants this product to be free of defects in material and workmanship at the time of purchase by the original retail consumer. KAO disclaims any other warranties, express or implied, including the warranty of fitness for a particular purpose or an intended use. If the product is found to be defective, KAO may replace or repair the product at our option, when the product is returned prepaid, with proof of purchase. Alteration to, improper installation, or misuse of this product voids the warranty. KAO's liability is limited to repair or replacement of products found to be defective, and specifically excludes liability for any incidental or consequential loss or damage.