

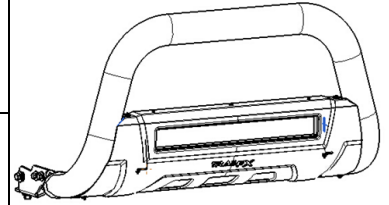

# 3.5" Oval Bull Bar

## Part No. B1601S/B



Fits: **2007 - Current Chevrolet Silverado/GMC Sierra 1500**



ASSISTANCE IS RECOMMENDED.



60-180 min

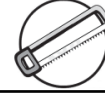

Cutting Required



Drilling Not Required



REMOVE CONTENTS FROM BOX. VERIFY ALL PARTS ARE PRESENT.



READ INSTRUCTIONS CAREFULLY BEFORE STARTING INSTALLATION.

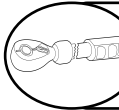

DO NOT OVER TORQUE. STANDARD OPERATING LOAD FOR TIGHTEN BODY MOUNT NUTS & BOLTS VARIES FROM **45** TO **65** FOOT POUND.

### PARTS LIST:

Qty	Part Description	Qty	Part Description
1	Bull Bar	6	12mm x 24mm OD x 2.5mm Flat Washers
1	Driver/Left Mounting Bracket	6	12-1.75mm Nylon Lock Nuts
1	Passenger/Right Mounting Bracket	4	10-1.50mm x 30mm Hex Bolts
2	12mm x 30mm Double Bolt Plates	8	10mm x 27mm OD x 3mm Flat Washers
2	12mm x 35mm Single Bolt Plates	4	10-1.50mm Nylon Lock Nuts

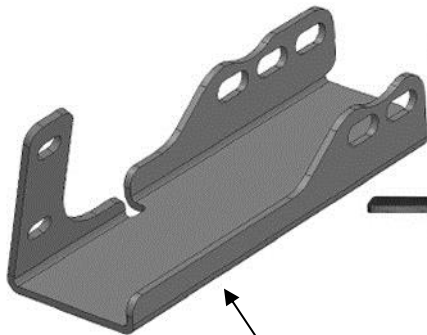

Passenger/Right Mounting Bracket



(2) 12mm x 35mm Single Bolt Plates

(2) 12mm x 30mm Double Bolt Plates

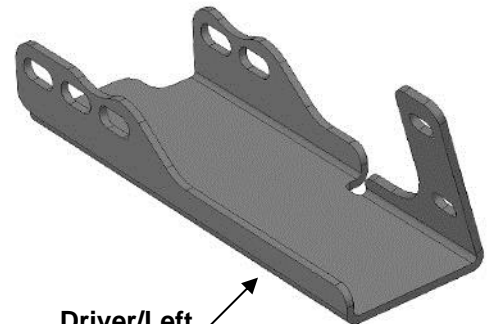

Driver/Left Mounting Bracket

## INSTALLATION PROCEDURE:

### CUTTING MAY BE REQUIRED. INSTALLATION MAY INTERFERE WITH FRONT MOUNTED SENSORS. NOTE:

It may be necessary to remove/relocate front license plate and license plate bracket. It is not required, but strongly recommended. If local/state law requires a front license plate, license plate relocation kit is available.

1. Start installation from under the front of the vehicle. Determine if the vehicle is equipped with tow hooks. **IMPORTANT:** Tow hooks cannot be reinstalled with the Bull Bar.

#### Tow Hook equipped vehicles:

Remove the tow hook from the end of each frame channel, **(Figure 1)**. Skip to **Step 2** if tow hooks were accessible and have been removed. **NOTE:** Tow hooks on 2014-on models may be difficult to remove and assistance is recommended. The following info only applies to the 2014-on models.



**(Fig 1) Example of Tow hook**

- a. On models with factory fog lights, unplug the wiring harnesses leading to the bumper.
- b. Open the hood and remove the plastic cover from the top of the radiator. Remove the bolts attaching the bottom of the grille if attached to the cross member. Remove the grille.
- c. On 2014-15 models, from behind the bumper, release the clips and hardware to remove the plastic body panel, (facial), on top of the bumper between the bottom of the grille and the top of the bumper, **(Figure 2)**.

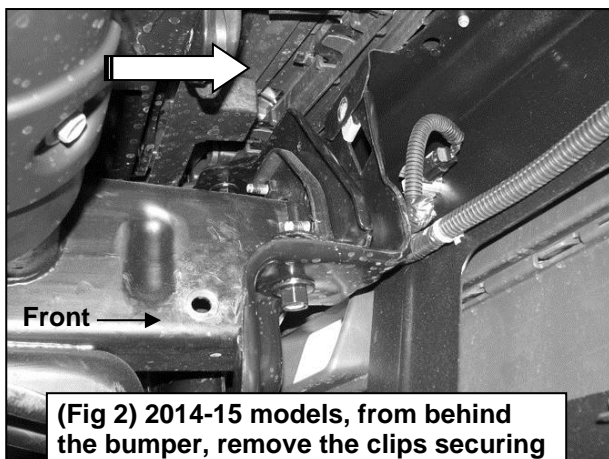

**(Fig 2) 2014-15 models, from behind the bumper, remove the clips securing the fascia to the top of the bumper**

- d. Remove the outer bumper supports on each side of the frame.
- e. Place blocks or jack stands under the front bumper to support it during mounting bolt removal. Once the bumper has been safely supported, remove the factory bumper bolts attaching the bumper to the inner bumper bracket bolted to the end of the frame, **(Figures 2 & 3)**. **WARNING!** Assistance is required to hold the bumper in place during bolt removal to prevent the bumper from falling. Carefully slide the bumper assembly with brackets off of the ends of the frame.

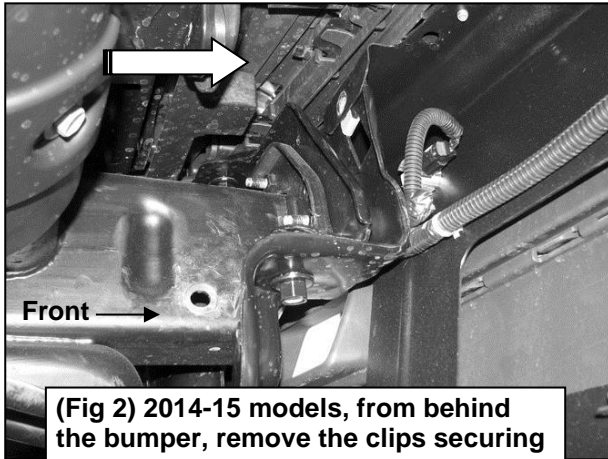

(Fig 2) 2014-15 models, from behind the bumper, remove the clips securing the fascia to the top of the bumper

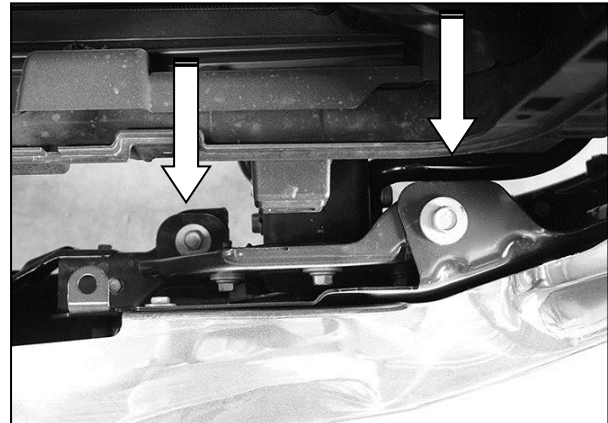

(Fig 3) 2016 model to show bumper bolt locations from above (arrows) with grille removed. 2014-15 models also remove plastic fascia panel to access bumper bolts as necessary

- f. Once bumper has been removed, remove both tow hooks and seals if equipped.
- g. Reattach the bumper, facial panel if equipped and grille after both tow hooks have been removed and the openings have been checked for Bracket clearance. Trim around openings as required for Bracket clearance.
- h. Tighten all factory bumper hardware at this time.
- i. Proceed to **Step 2**.

**Vehicles without tow hooks:**

- a. Cut out the indented area in both sides of the plastic bumper insert to clear the Brackets as pictured, **(Figures 4 & 5)**. **IMPORTANT:** Make several small cuts for best fit. Do not cut through the top edge of the panel. **NOTE:** On 2014-15 models, the plastic panel is held in place with several small screws. The screws at the top corners are difficult to reach and remove without damaging the cover with the bumper in place. If you prefer to remove the panel to cut out the openings, it will be easier to remove the bumper assembly, (see previous tow hook instructions), with the panel attached.

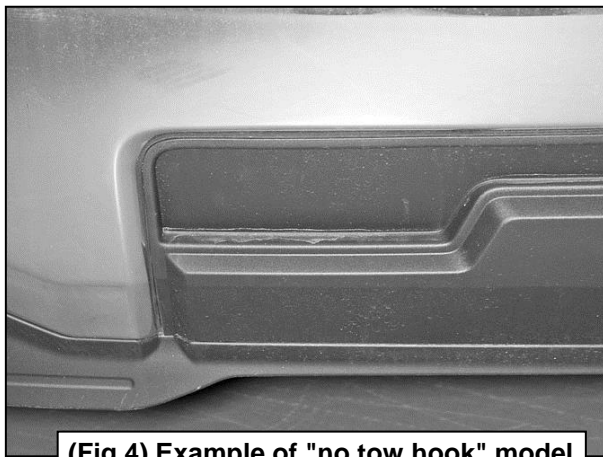

(Fig 4) Example of "no tow hook" model

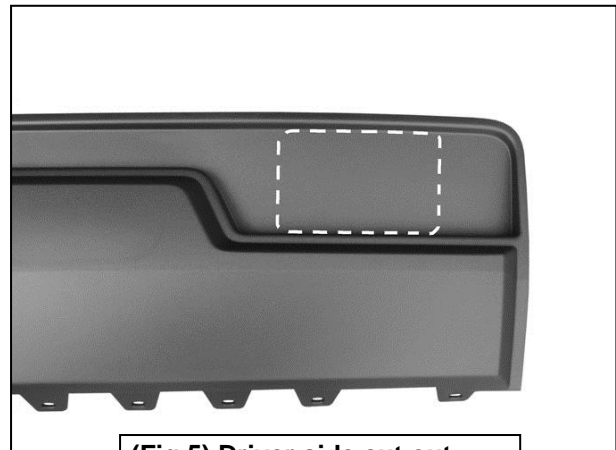

(Fig 5) Driver side cut out illustrated for reference only

2. Select the driver side Mounting Bracket. Insert the Bracket through the opening in the bumper, **(Figure 6)**. Trim the plastic as required clearing the Brackets.

Mounting holes in end of frame for tow hook

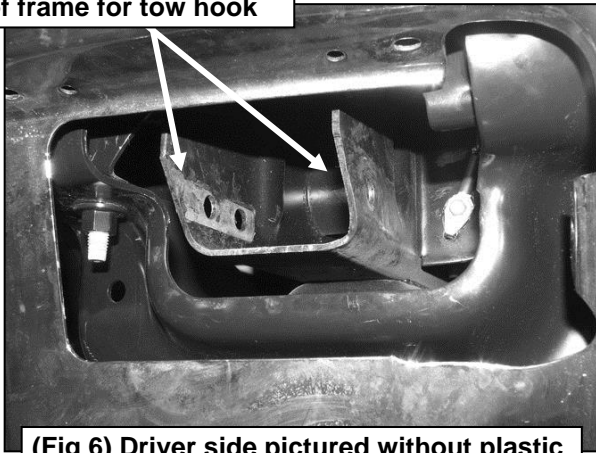

(Fig 6) Driver side pictured without plastic panel for instruction purposes only

3. Line up the holes in the Bracket with the holes in the end of the frame for the tow hook, **(Figure 6)**. Select (1) 12mm Double Bolt Plate, **(Figure 7)**. Insert the Bolt Plate into the end of the frame, through the (2) holes in the side of the frame and out through the Bracket, **(Figures 8 & 9)**. Attach the Bracket to the Bolt Plate with (2) 12mm Flat Washers and (2) 12mm Nylon Lock Nuts. Snug but do not fully tighten hardware at this time.

Mounting holes in end of frame for tow hook

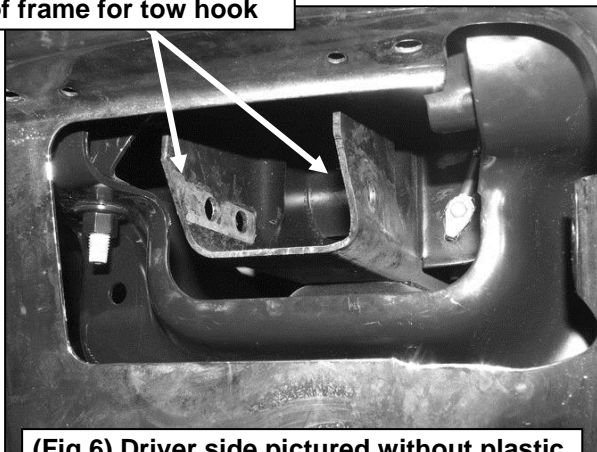

(Fig 6) Driver side pictured without plastic panel for instruction purposes only

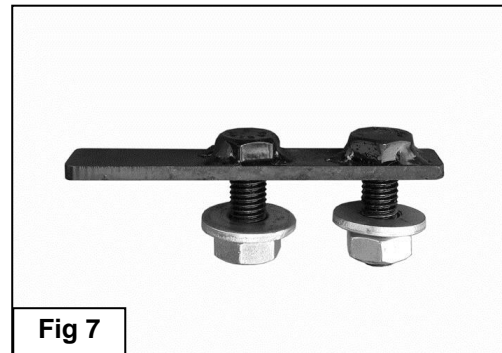
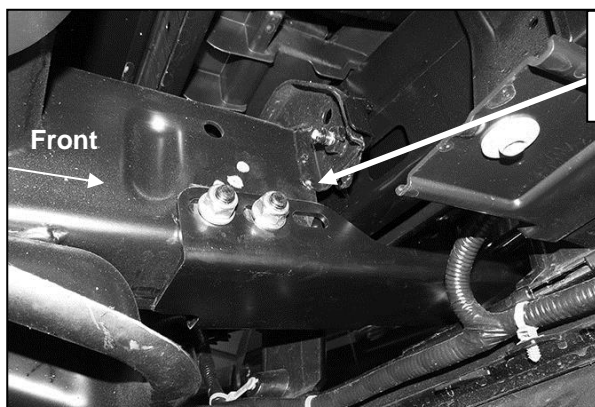
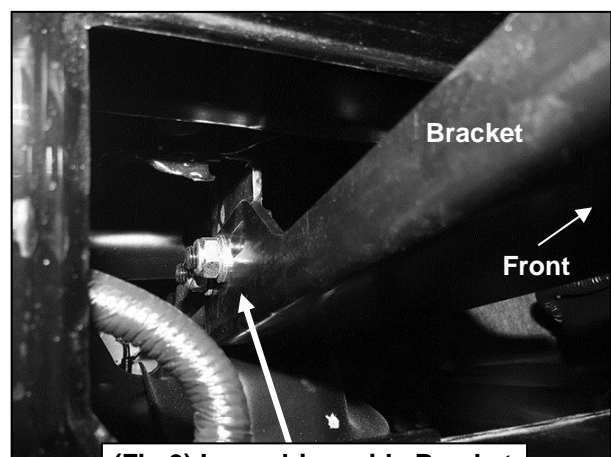

Fig 7



(Fig 8) Note Bracket installed in "forward" position to move Bull Bar away from bumper

12mm Double Bolt Plate  
(2) 12mm Flat Washers  
(2) 12mm Nylon Lock Nuts



(Fig 9) Inner driver side Bracket with Double Bolt Plate

4. Repeat **Step 3** to install the 12mm x 35mm Single Bolt Plate, **(Figure 10)**, into the remaining hole in the other side of the frame and Bracket, **(Figures 11 & 12)**.

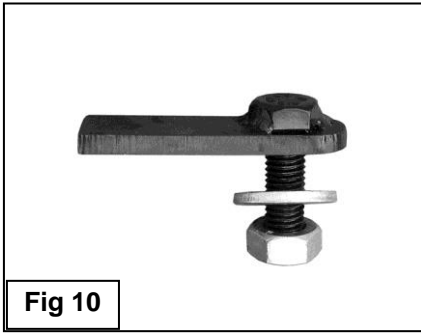
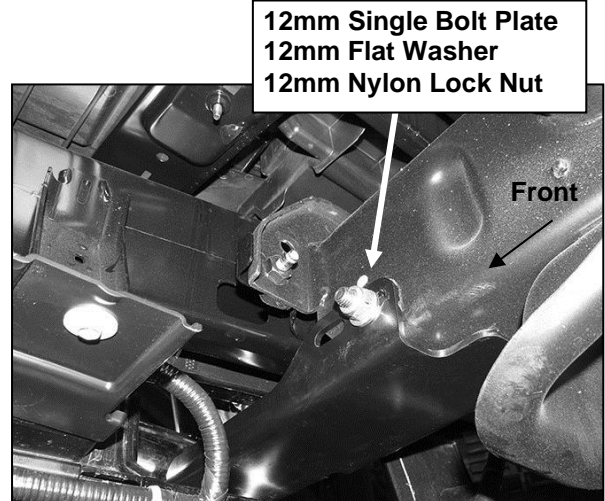
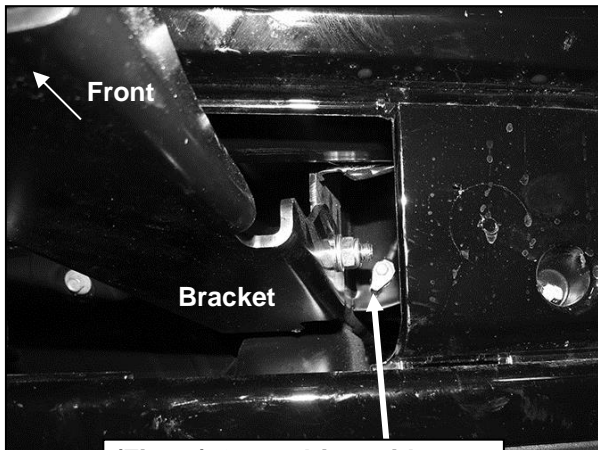

Fig 10



(Fig 11) Passenger Bracket installed in "forward" position to move Bull Bar away from bumper



(Fig 12) Outer driver side Bracket with Single Bolt Plate

**IMPORTANT:** The Brackets are designed with (2) mounting positions to fit multiple models and model years. Most Silverado/Sierra models will use the "back" mounting position with the Brackets pushed in to install the Bull Bar closer to the bumper, **(Figure 13)**. Tahoe, Yukon and Suburban models may require the forward mounting position to move the Bull Bar forward or to provide more clearance for accessory lights, **(Figure 14)**.

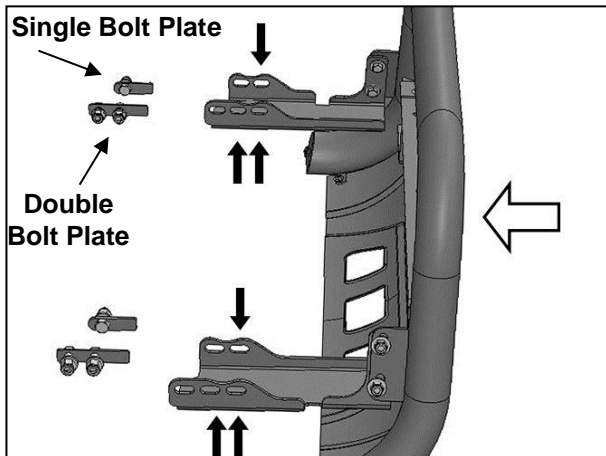

(Fig 13) Typical Silverado/Sierra mounting position

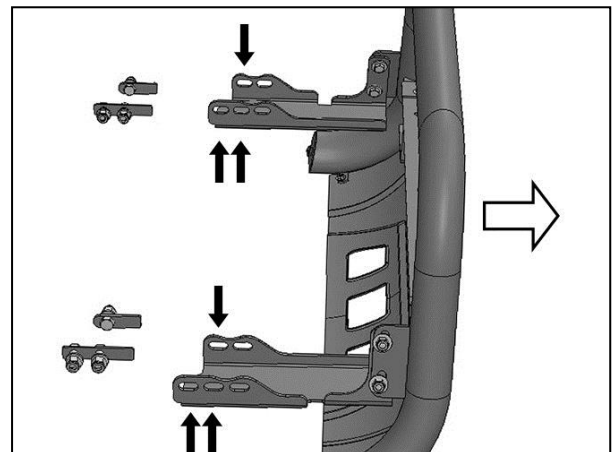

(Fig 14) Typical Tahoe/Yukon and Suburban mounting position

5. Repeat **Steps 2—4** to install the passenger side Mounting Bracket.
6. With assistance, hold the Bull Bar up in position on the outside of the Mounting Brackets. Attach the Bull Bar to the Brackets with (4) 10mm x 30mm Hex Bolts, (8) 10mm Flat Washers and (4) 10mm Nylon Lock Nuts, **(Figures 15 & 16)**. Do not tighten hardware at this time.

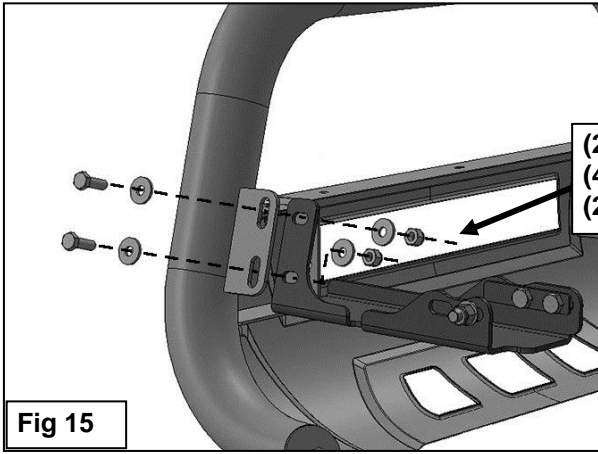

- (2) 10mm x 30mm Hex Bolts
- (4) 10mm Flat Washers
- (2) 10mm Nylon Lock Nuts



7. Check the Bull Bar alignment with the vehicle and for clearance between the Bull Bar and the bumper. If Bull Bar is too close to or touching bumper, remove the Bull Bar and reinstall the Brackets in the “forward” position away from the bumper, (**Figure 14**). Adjust as required then fully tighten all hardware at this time.

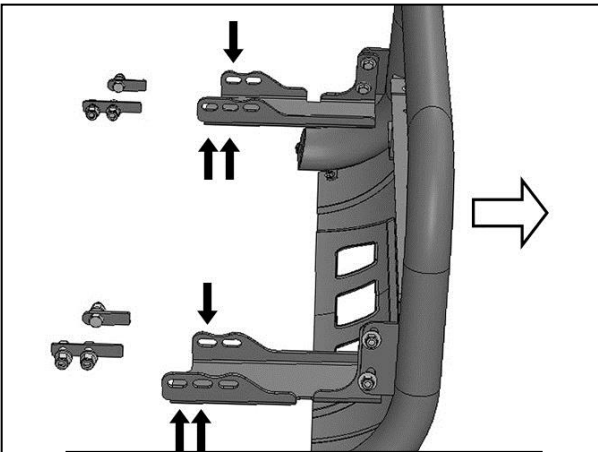

(Fig 14) Typical Tahoe/Yukon and Suburban mounting position

8. Do periodic inspections to the installation to make sure that all hardware is secure and tight.



Complete Installation (light available separately)



## PRODUCT CARE

- Periodically check the product to ensure all fasteners are tight and components are intact.
- Regular waxing is recommended to protect the finish of the product.
- **Use ONLY Non-Abrasive automotive wax.** Use of any soap, polish or wax that contains an abrasive is detrimental and can scratch the finish leading to corrosion.
- Aluminum polish may be used to polish small scratches and scuffs for **Stainless Steel finish.**
- Mild soap may be used to clean the product for both **Stainless Steel and Black finish.**

## FAQ's

**1. Hardware's are not of correct size.**

*In GMC / Chevrolet truck model 2006 & up, customer needs to reuse the factory body bolts to install the bracket. If your vehicle is not GMC / Chevrolet 2006 & up, ensure that holes are not partially covered with any plastic grommet or rust? If it is, remove the plastic grommet & rust from the thread holes & re-try the installation.*

**2. Mounting Bracket are not getting Installed properly.**

*In some cases Illustration images shown in Installation manual may not be the exactly same as per actual vehicle images ,also if Driver / Passenger side mounting brackets are very identical in the design, suggest referring Parts Identification guide to avoid fitment issue.*

**3. Products are thumping / rattling after installation.**

*Ensure that all required mounting brackets / hardware's are installed & tighten correctly. Suggest using white lithium / regular grease between the metal to metal contact surfaces.*

**4. Side Bar is not aligning with vehicle / Step Pads are not aligning with vehicle doors.**

*Side bar may be interchanged or mounting brackets are not installed at the correct position in the vehicle. Refer Parts identification guide.*

**5. Missing / Excess Hardware.**

*Recheck hardware count as per the part list.*

**6. Product not installing properly.**

*Ensure make model year, cab length and bed size of your vehicle is listed in the application. All installation steps are followed correctly.*

## Check out these other TrailFX Products!!



**BULL BAR**



**GRILLE GUARDS**



**BED RAILS**



**RUNNING BOARDS**

*Keystone Automotive Operations Inc. (KAO) warrants this product to be free of defects in material and workmanship at the time of purchase by the original retail consumer. KAO disclaims any other warranties, express or implied, including the warranty of fitness for a particular purpose or an intended use. If the product is found to be defective, KAO may replace or repair the product at our option, when the product is returned prepaid, with proof of purchase. Alteration to, improper installation, or misuse of this product voids the warranty. KAO's liability is limited to repair or replacement of products found to be defective, and specifically excludes liability for any incidental or consequential loss or damage.*