

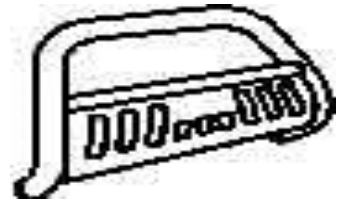

# 3" Bull Bar

## Part No. B0036S/B



Fits: 2019

Silverado 1500 / Crew Cab



60-180 min

Cutting Maybe Required

Drilling Not Required



REMOVE CONTENTS FROM BOX. VERIFY ALL PARTS ARE PRESENT.



READ INSTRUCTIONS CAREFULLY BEFORE STARTING INSTALLATION.

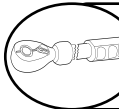

DO NOT OVER TORQUE. STANDARD OPERATING LOAD FOR TIGHTEN BODY MOUNT NUTS & BOLTS VARIES FROM 45 TO 65 FOOT POUND.

### PARTS LIST:

Qty	Part Description	Qty	Part Description
1	Bull Bar	6	12mm x 24mm OD x 2.5mm Flat Washers
1	Driver/Left Mounting Bracket	6	12-1.75mm Nylon Lock Nuts
1	Passenger/Right Mounting Bracket	4	10-1.50mm x 30mm Hex Bolts
2	12-1.75mm x 30mm Double Bolt Plates	8	10mm x 27mm OD x 3mm Flat Washers
2	12-1.75mm x 35mm Single Bolt Plates	4	10-1.50mm Nylon Lock Nuts

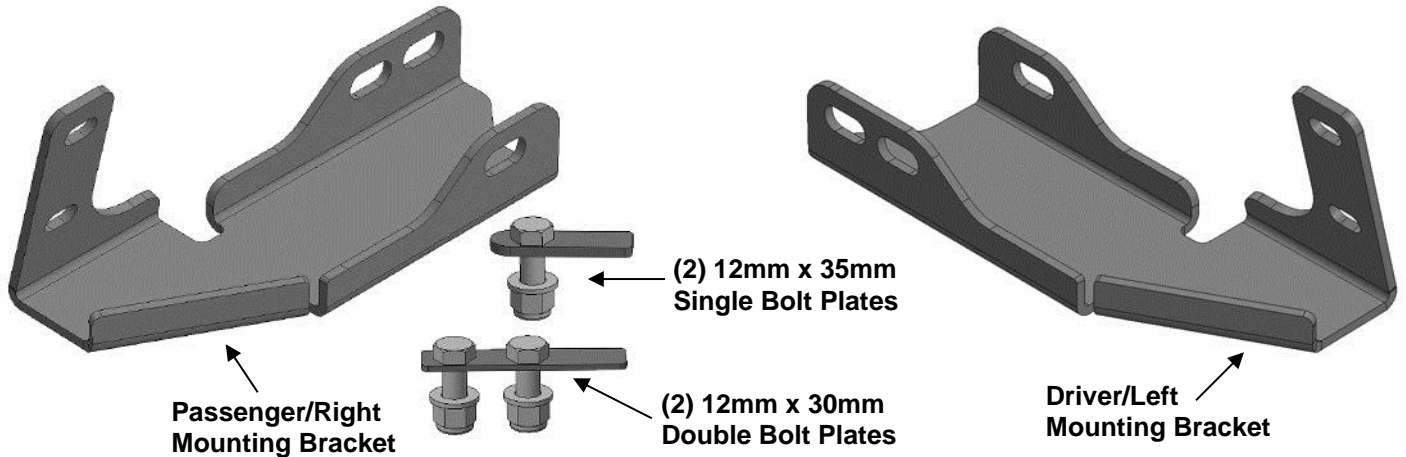

### INSTALLATION PROCEDURE:

INSTALLATION MAY INTERFERE WITH FRONT MOUNTED SENSORS.

**NOTE:** It may be necessary to remove/relocate front license plate and license plate bracket. It is not required, but strongly recommended. If local/state law requires a front license plate, license plate relocation kit is available.

1. Start installation from under the front of the vehicle. Determine if the vehicle is equipped with tow hooks. **IMPORTANT:** Tow hooks cannot be reinstalled with the Bull Bar.

#### Tow Hook equipped vehicles:

- a. Remove the factory tow hook from the end of each frame channel, **(Figures 1—3)**.
- b. Select the passenger/right Mounting Bracket. Insert the Bracket through the opening in the bumper and up to the frame. Trim the plastic as required to clear the Bracket, **(Figure 5)**. Repeat to check for clearance on driver/left side of bumper.
- c. Proceed to **Step 2**.

**Vehicles without tow hooks:**

- a. Cut out the indented area in both sides of the plastic bumper insert to clear the Brackets as pictured, **(Figures 4 & 5)**. **IMPORTANT:** Make several small cuts for best fit.
  - b. Check for clearance between Brackets and opening and trim the plastic as required to clear the Brackets.
2. Line up the holes in the Bracket with the holes in the end of the frame channel for the tow hook, **(Figure 5)**. Select (1) 12mm Double Bolt Plate, **(Figure 6)**. Insert the Bolt Plate into the end of the frame and out through the (2) holes in the side of the frame and out through the Bracket, **(Figures 6 & 8)**. Secure the Bracket to the Bolt Plate with (2) 12mm Flat Washers and (2) 12mm Nylon Lock Nuts. Leave hardware loose at this time.
  3. Repeat **Step 2** to install the 12mm x 35mm Single Bolt Plate, **(Figure 9)**, into the single forward tow hook mounting hole in the other side of the frame channel and Bracket, **(Figures 6, 10 & 11)**.
  4. Repeat **Steps 2 & 3** to install the driver/left Mounting Bracket.
  5. With assistance, hold the Bull Bar up in position on the outside of the Mounting Brackets. Attach the Bull Bar to the Brackets with (4) 10mm x 30mm Hex Bolts, (8) 10mm Flat Washers and (4) 10mm Nylon Lock Nuts, **(Figures 12 & 13)**. Do not tighten hardware at this time.
  6. Check the Bull Bar alignment with the vehicle and for clearance between the Bull Bar and the bumper. Adjust as required then fully tighten all hardware at this time.
  7. Do periodic inspections to the installation to make sure that all hardware is secure and tight.

**Passenger/right Side Installation Pictured**

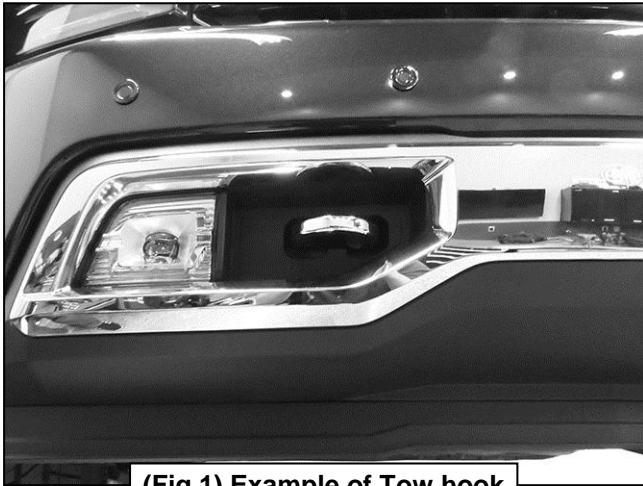

**(Fig 1) Example of Tow hook**

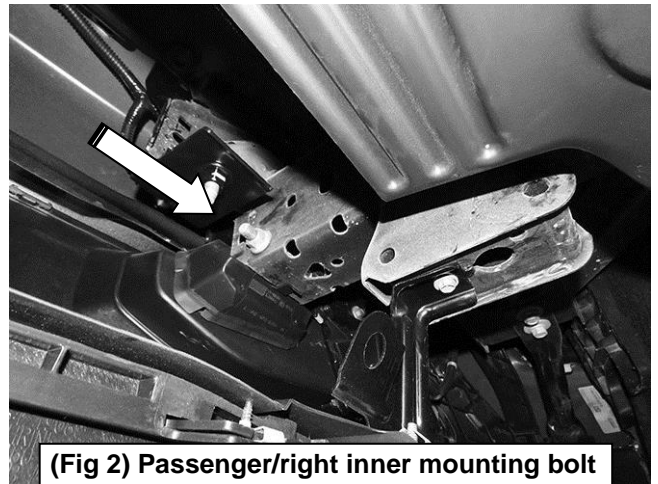

**(Fig 2) Passenger/right inner mounting bolt for tow hook pictured from behind bumper**



**(Fig 3) Passenger/right outer mounting bolts for tow hook pictured from behind bumper**

**Area to cut out illustrated for example only**



**(Fig 4) Example of model without tow hooks**

# Passenger/right Side Installation Pictured

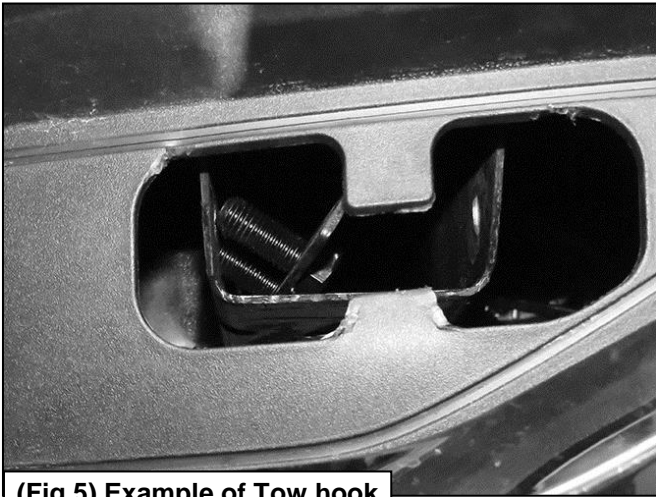

(Fig 5) Example of Tow hook

- (1) 12mm Double Bolt Plate
- (2) 12mm Flat Washers
- (2) 12mm Nylon Lock Nuts

- (1) 12mm Single Bolt Plate
- (1) 12mm Flat Washer
- (1) 12mm Nylon Lock Nut

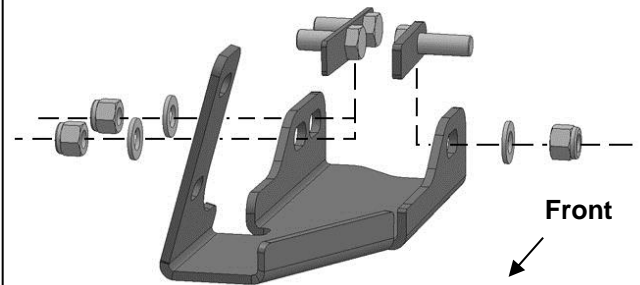

(Fig 6) Passenger/right side Bracket illustrated

- 12mm Double Bolt Plate
- (2) 12mm Flat Washers
- (2) 12mm Nylon Lock Nuts

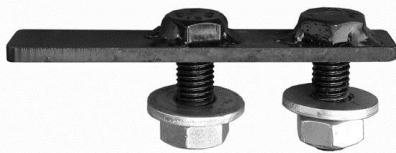
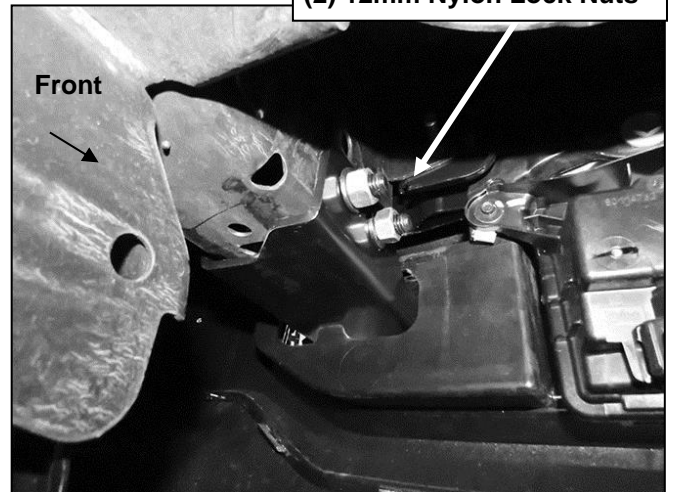

Fig 7

- (1) 12mm Double Bolt Plate
- (2) 12mm Flat Washers
- (2) 12mm Nylon Lock Nuts



(Fig 8) Outer passenger/right side Bracket with Double Bolt Plate pictured from behind bumper

- 12mm Single Bolt Plate
- 12mm Flat Washer
- 12mm Nylon Lock Nut

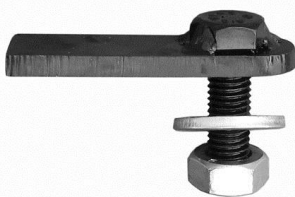
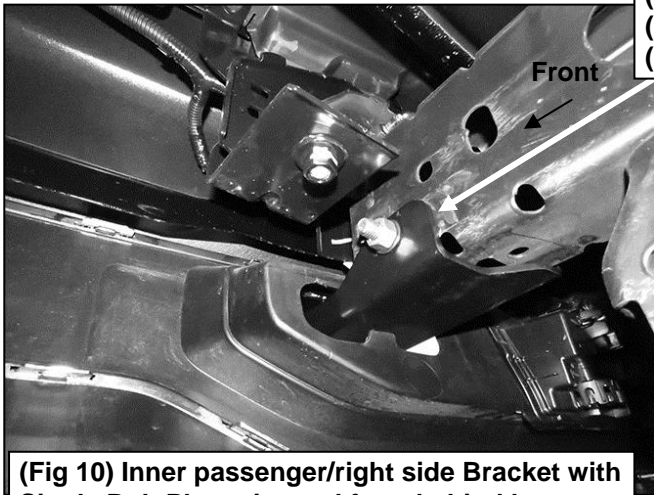

Fig 9



- (1) 12mm Single Bolt Plate
- (1) 12mm Flat Washer
- (1) 12mm Nylon Lock Nut

**(Fig 10) Inner passenger/right side Bracket with Single Bolt Plate pictured from behind bumper**

- (2) 10mm Hex Bolts
- (4) 10mm Flat Washers
- (2) 10mm Nylon Lock Nuts

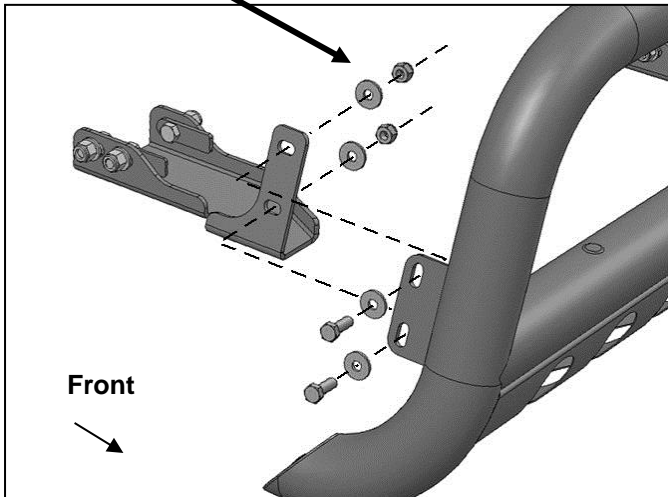

**(Fig 12) Attach Bull Bar to outside of Brackets. Passenger/right side complete installation**



**(Fig 11) Passenger/right side Bracket installed**

- (2) 10mm x 30mm Hex Bolts
- (4) 10mm Flat Washers
- (2) 10mm Nylon Lock Nuts



**(Fig 13) Passenger/right side complete installation**

## PRODUCT CARE

- Periodically check the product to ensure all fasteners are tight and components are intact.
- Regular waxing is recommended to protect the finish of the product.
- **Use ONLY Non-Abrasive automotive wax.** Use of any soap, polish or wax that contains an abrasive is detrimental and can scratch the finish leading to corrosion.
- Aluminum polish may be used to polish small scratches and scuffs for **Stainless Steel finish.**
- Mild soap may be used to clean the product for both **Stainless Steel and Black finish.**

## FAQ's

### 1. Hardware's are not of correct size.

*In GMC / Chevrolet truck model 2006 & up, customer needs to reuse the factory body bolts to install the bracket. If your vehicle is not GMC / Chevrolet 2006 & up, ensure that holes are not partially covered with any plastic grommet or rust? If it is, remove the plastic grommet & rust from the thread holes & re-try the installation.*

### 2. Mounting Bracket are not getting Installed properly.

*In some cases Illustration images shown in Installation manual may not be the exactly same as per actual vehicle images ,also if Driver / Passenger side mounting brackets are very identical in the design, suggest referring Parts Identification guide to avoid fitment issue.*

### 3. Products are thumping / rattling after installation.

*Ensure that all required mounting brackets / hardware's are installed & tighten correctly. Suggest using white lithium / regular grease between the metal to metal contact surfaces.*

### 4. Side Bar is not aligning with vehicle / Step Pads are not aligning with vehicle doors.

*Side bar may be interchanged or mounting brackets are not installed at the correct position in the vehicle. Refer Parts identification guide.*

### 5. Missing / Excess Hardware.

*Recheck hardware count as per the part list.*

### 6. Product not installing properly.

*Ensure make model year, cab length and bed size of your vehicle is listed in the application. All installation steps are followed correctly.*

## Check out these other TrailFX Products!!



**BULL BAR**



**GRILLE GUARDS**



**BED RAILS**



**RUNNING BOARDS**

Keystone Automotive Operations Inc. (KAO) warrants this product to be free of defects in material and workmanship at the time of purchase by the original retail consumer. KAO disclaims any other warranties, express or implied, including the warranty of fitness for a particular purpose or an intended use. If the product is found to be defective, KAO may replace or repair the product at our option, when the product is returned prepaid, with proof of purchase. Alteration to, improper installation, or misuse of this product voids the warranty. KAO's liability is limited to repair or replacement of products found to be defective, and specifically excludes liability for any incidental or consequential loss or damage.