

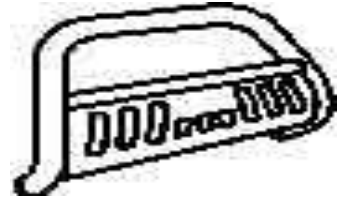

# 3" Bull Bar

## Part No.B0033S/B



Fits: 2007 - Current Chevrolet Silverado/ GMC Sierra 1500 /2007-2013 Chevy Avalanche  
 2007 - Current Chevrolet Suburban 1500 /2007-2015 Chevy Tahoe  
 2007-2015 GMC Yukon &Yukon XL  
 2007 - Current Cadillac Escalade 1500/ESV/EXT



60-180 min



Cutting Required



Drilling Not Required



REMOVE CONTENTS FROM BOX. VERIFY ALL PARTS ARE PRESENT.



READ INSTRUCTIONS CAREFULLY BEFORE STARTING INSTALLATION.

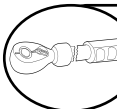

DO NOT OVER TORQUE. STANDARD OPERATING LOAD FOR TIGHTEN BODY MOUNT NUTS & BOLTS VARIES FROM 45 TO 65 FOOT POUND.

### PARTS LIST:

Qty	Part Description	Qty	Part Description
1	Bull Bar	6	12mm x 24mm OD x 2.5mm Flat Washer
1	Driver/Left Mounting Bracket	6	12-1.75mm Nylon Lock Nut
1	Passenger/Right Mounting Bracket	4	10-1.50mm x 30mm Hex Bolt
2	12-1.75mm x 30mm Double Bolt Plate	8	10mm x 27mm OD x 3mm Flat Washer
2	12-1.75mm x 35mm Single Bolt Plate	4	10-1.50mm Nylon Lock Nut

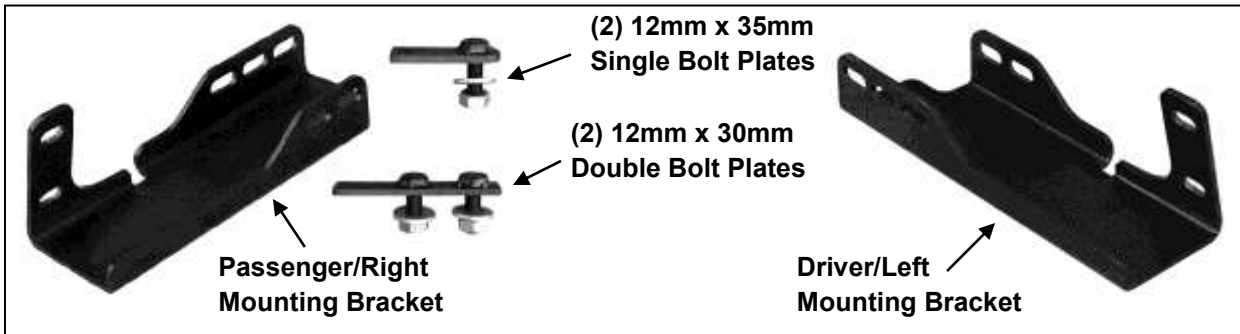

## INSTALLATION PROCEDURE:

**INSTALLATION MAY INTERFERE WITH FRONT MOUNTED SENSORS. NOTE:** It may be necessary to remove/relocate front license plate and license plate bracket. It is not required, but strongly recommended. If local/state law requires a front license plate, license plate relocation kit is available.

1. Start installation from under the front of the vehicle. Determine if the vehicle is equipped with tow hooks. **IMPORTANT:** Tow hooks cannot be reinstalled with the Bull Bar.

### Tow Hook equipped vehicles:

- a. Remove the factory tow hook from the end of each frame channel, (**Figure 1**). Skip to **Step 2** if tow hooks were accessible and have been removed. **NOTE:** The driver side tow hook on some later models may be difficult to remove and assistance is highly recommended on these models. The following info only applies to the later GM models.

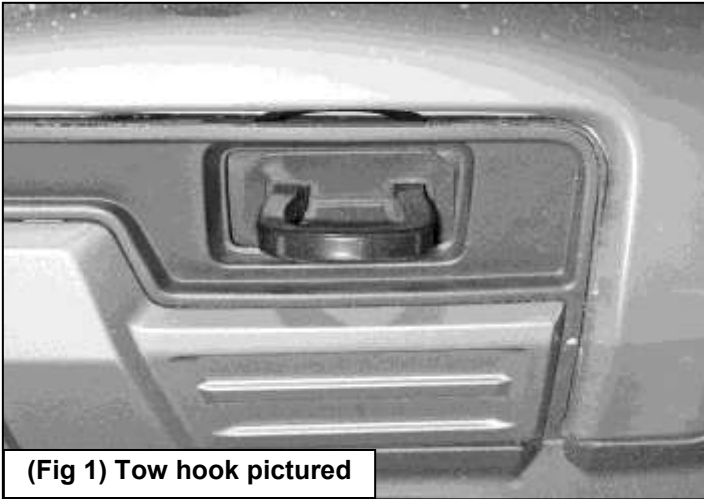

- i. **Tow hook removal-option 1:** Remove the hex bolts securing the driver side of the bumper to the bracket. Use a short pry bar or large screwdriver to move the tab on the bumper bracket up and away to clear the hex bolt and slide it out past the bumper bracket, (**Figures 2A, 2B**).

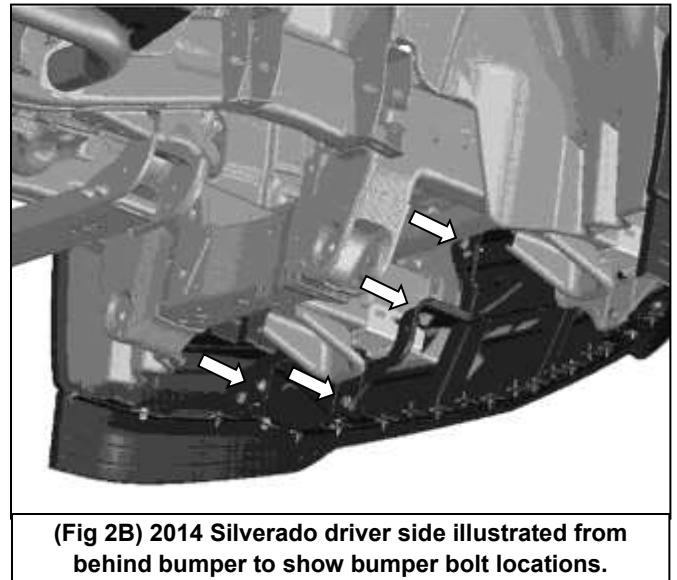
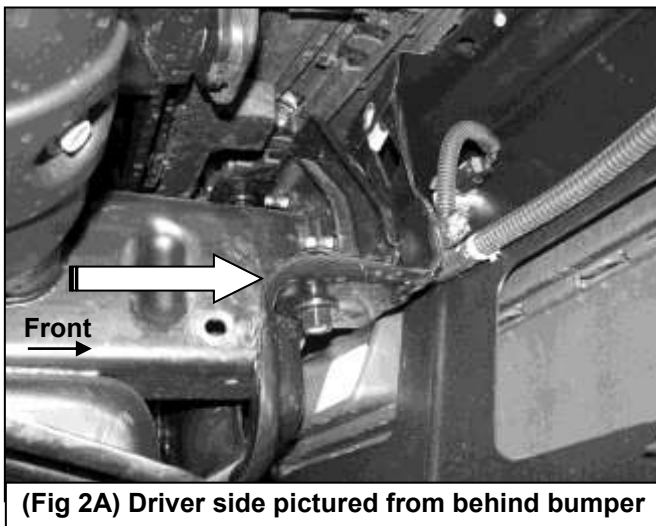

Remove the bolts securing the driver side of the bumper to the bumper bracket. Use a large screwdriver or pry bar to move the mounting tab up enough to get the long bolt through the tow hook out of the end of the frame

ii. **Option 2:** Remove plastic radiator grille. Loosen and/or completely remove the front bumper to remove the long hex bolt in the driver side tow hook, **(Figure 2B)**.

- b. Reattach the bumper after both tow hooks have been removed and the openings have been checked for Bracket clearance. Tighten all factory bumper hardware at this time.
- c. Proceed to **Step 2**.

**Vehicles without tow hooks:**

- a. Cut out the indented area in both sides of the plastic bumper insert to clear the Brackets as pictured, **(Figures 3 & 4)**. **IMPORTANT:** Make several small cuts for best fit. Do not cut through the top edge of the panel. **NOTE:** On some later models, the plastic panel is held in place with several small screws. The screws at the top corners are difficult to impossible to reach and remove without damaging the cover with the bumper in place. If you prefer to remove the panel to cut out the openings, it may be necessary or easier to remove the plastic grille then the steel bumper assembly with the plastic panel attached to access all of the small screws and clips.

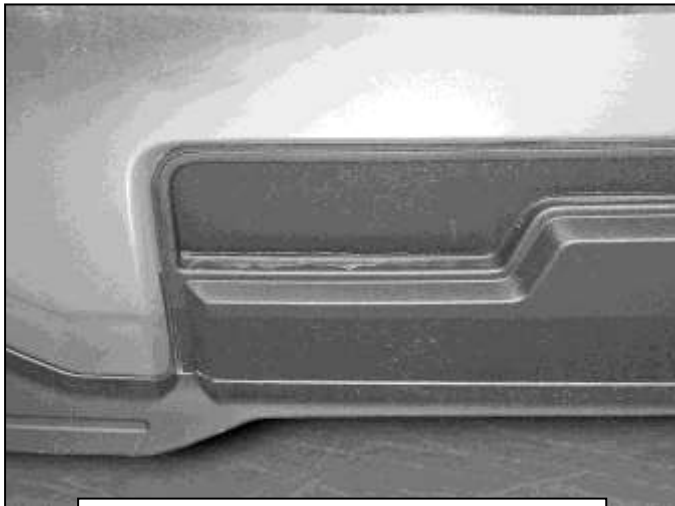

**(Fig 3) Example of "no tow hook" model**

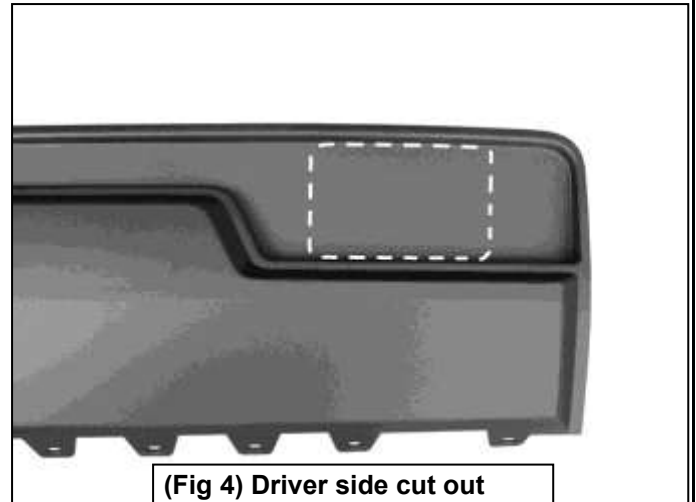

**(Fig 4) Driver side cut out illustrated for reference only**

- b. Reattach the bumper and/or bumper insert, (if removed), and grille once openings have been cut out and checked for clearance. Tighten all factory bumper hardware at this time.
2. Select the driver side Mounting Bracket. Insert the Bracket through the opening in the bumper, **(Figure 5)**. Trim the plastic as required to clear the Brackets.

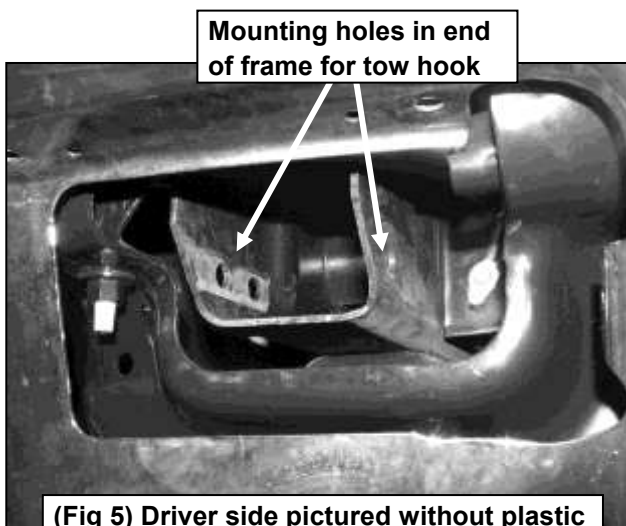

**(Fig 5) Driver side pictured without plastic panel for instruction purposes only**

3. Line up the holes in the Bracket with the holes in the end of the frame channel for the tow hook. Select (1) 12mm Double Bolt Plate, (**Figure 6A**). Insert the Bolt Plate into the end of the frame, through the (2) holes in the side of the frame and out through the Bracket, (**Figures 5, 6B & 6C**). Secure the Bracket to the Bolt Plate with (2) 12mm Flat Washers and (2) 12mm Nylon Lock Nuts, (**Figure 6C**). Snug but do not fully tighten hardware at this time.

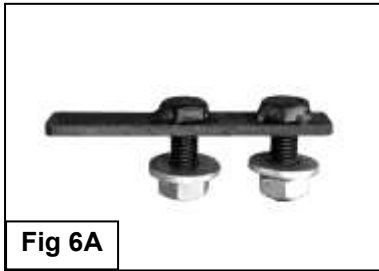
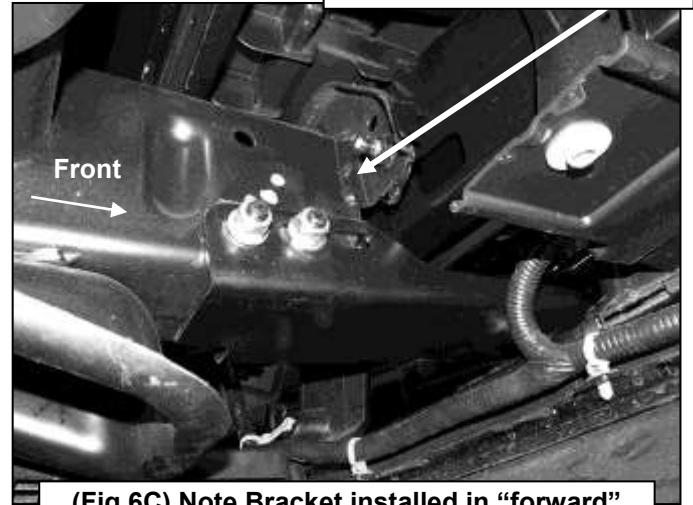

Fig 6A

12mm Double Bolt Plate  
 (2) 12mm Flat Washers  
 (2) 12mm Nylon Lock Nuts



(Fig 6B) Inner driver side Bracket with Double Bolt Plate



(Fig 6C) Note Bracket installed in "forward" position to move Bull Bar away from bumper

4. Repeat **Step 3** to install the 12mm x 35mm Single Bolt Plate, (**Figure 7A**), into the remaining hole in the other side of the frame channel and Bracket, (**Figures 5, 7B & 7C**).



Fig 7A

12mm Single Bolt Plate  
 12mm Flat Washer  
 12mm Nylon Lock Nut

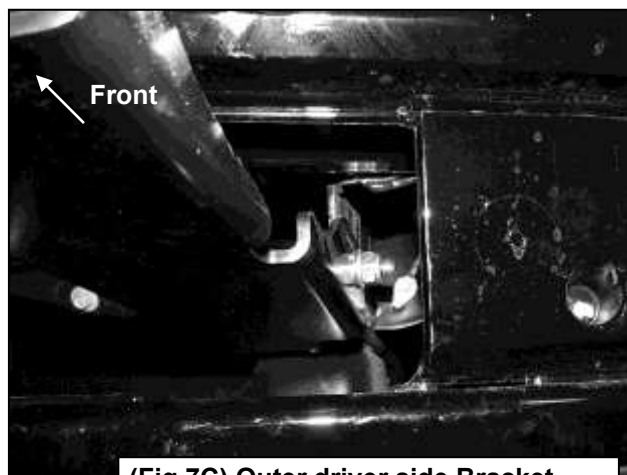

(Fig 7C) Outer driver side Bracket with Single Bolt Plate



(Fig 7B) Passenger Bracket installed in "forward" position to move Bull Bar away from bumper

5. **IMPORTANT:** The Brackets are designed with (2) mounting positions to fit multiple models and model years. Most Silverado/Sierra models will use the “back” mounting position with the Brackets pushed in to install the Bull Bar closer to the bumper, (**Figure 8A**). Tahoe, Yukon and Suburban models may require the forward mounting position to move the Bull Bar forward or to provide more clearance for accessory lights, (**Figure 8B**).

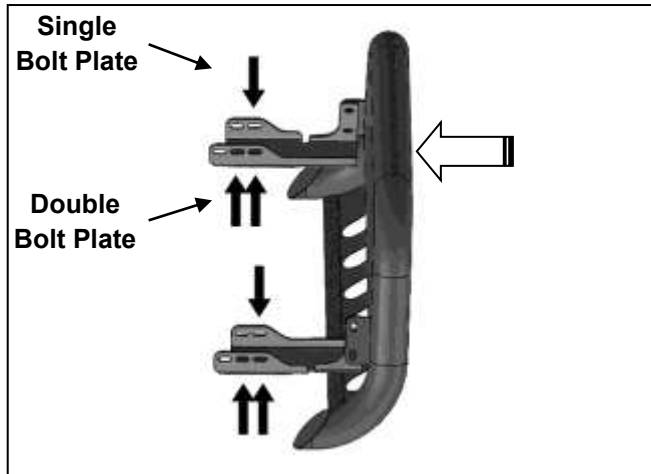

(Fig 8A) Typical Silverado/Sierra mounting position

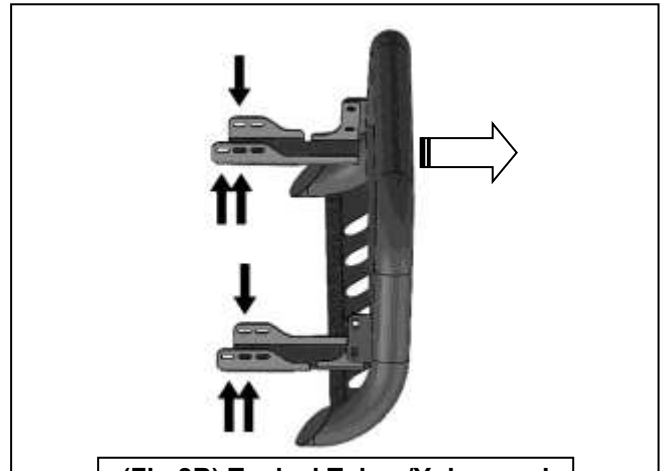

(Fig 8B) Typical Tahoe/Yukon and Suburban mounting position

6. Repeat **Steps 2—5** to install the passenger side Mounting Bracket.
7. With assistance, hold the Bull Bar up in position on the outside of the Mounting Brackets. Bolt the Bull Bar to the Brackets with (4) 10mm x 30mm Hex Bolts, (8) 10mm Flat Washers and (4) 10mm Nylon Lock Nuts, (**Figure 9**). Do not tighten hardware at this time.

(2) 10mm x 30mm Hex Bolts  
 (4) 10mm Flat Washers  
 (2) 10mm Nylon Lock Nuts

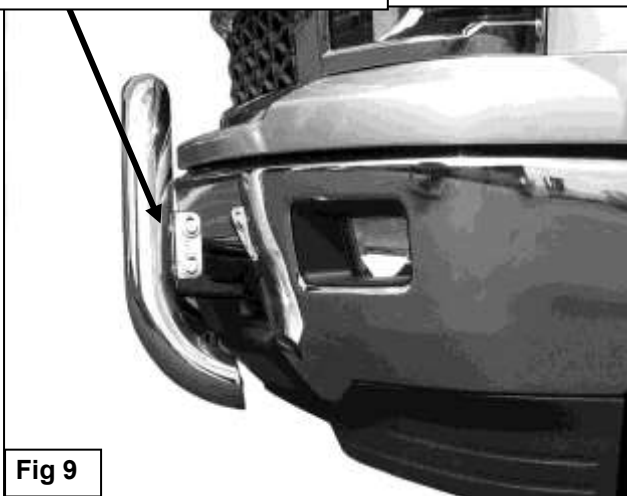

Fig 9

8. Check the Bull Bar alignment with the vehicle and for clearance between the Bull Bar and the bumper. If Bull Bar is too close to or touching bumper, remove the Bull Bar and reinstall the Brackets in the “forward” position away from the bumper. Adjust as required then fully tighten all hardware at this time.
9. Do periodic inspections to the installation to make sure that all hardware is secure and tight.



Complete Installation

## PRODUCT CARE

- Periodically check the product to ensure all fasteners are tight and components are intact.
- Regular waxing is recommended to protect the finish of the product.
- **Use ONLY Non-Abrasive automotive wax.** Use of any soap, polish or wax that contains an abrasive is detrimental and can scratch the finish leading to corrosion.
- Aluminum polish may be used to polish small scratches and scuffs for **Stainless Steel finish.**
- Mild soap may be used to clean the product for both **Stainless Steel and Black finish.**

## FAQ's

**1. Hardware's are not of correct size.**

*In GMC / Chevrolet truck model 2006 & up, customer needs to reuse the factory body bolts to install the bracket. If your vehicle is not GMC / Chevrolet 2006 & up, ensure that holes are not partially covered with any plastic grommet or rust? If it is, remove the plastic grommet & rust from the thread holes & re-try the installation.*

**2. Mounting Bracket are not getting Installed properly.**

*In some cases Illustration images shown in Installation manual may not be the exactly same as per actual vehicle images ,also if Driver / Passenger side mounting brackets are very identical in the design, suggest referring Parts Identification guide to avoid fitment issue.*

**3. Products are thumping / rattling after installation.**

*Ensure that all required mounting brackets / hardware's are installed & tighten correctly. Suggest using white lithium / regular grease between the metal to metal contact surfaces.*

**4. Side Bar is not aligning with vehicle / Step Pads are not aligning with vehicle doors.**

*Side bar may be interchanged or mounting brackets are not installed at the correct position in the vehicle. Refer Parts identification guide.*

**5. Missing / Excess Hardware.**

*Recheck hardware count as per the part list.*

**6. Product not installing properly.**

*Ensure make model year, cab length and bed size of your vehicle is listed in the application. All installation steps are followed correctly.*