

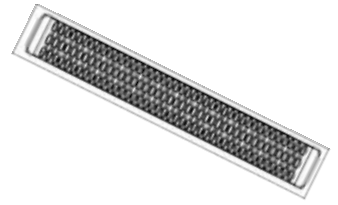

Aggressive Running Board-Van

Part No. ARBV003B



Fits: 2014 - Current

Dodge ProMaster (32"+96")



132& 159IN WHEELBASE ONLY



REMOVE CONTENTS FROM BOX. VERIFY ALL PARTS ARE PRESENT.



READ INSTRUCTIONS CAREFULLY BEFORE STARTING INSTALLATION.

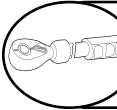

DO NOT OVER TORQUE. STANDARD OPERATING LOAD FOR TIGHTEN BODY MOUNT NUTS & BOLTS VARIES FROM 45 TO 65 FOOT POUND.



60-180 min



Cutting may be Required



Drilling Required

PARTS LIST:

Qty	Part Description	Qty	Part Description
1	Driver/left Steel Running Board	6	8-1.25mm x 25mm Hex Bolts
1	Passenger/right Steel Running Board	6	8mm x 28mm OD x 3mm Large Flat Washers
1	Driver/Left Side Front Bracket	12	8mm x 24mm OD x 2mm STD Flat Washers
1	Driver/Left Side Rear Bracket	12	8mm x 16mm OD x 1.6mm Small Flat Washers
1	Driver/Left Side Front Support Bracket	18	8mm Lock Washers
1	Passenger/Right Side Front Bracket	18	8mm Hex Nuts
3	Passenger/Right Side Center/Rear Brackets	6	8mm Nylon Lock Nuts
5	Passenger/Right Side Support Brackets (1-drv rear)	6	6mm x 25mm Hex Bolts
6	8-1.25mm x 35mm Button Head Bolt Plates	12	6mm x 18mm OD x 1.6mm Flat Washers
6	8mm Plastic Retainers	6	6mm Lock Washers
6	8mm Double Bolt Plates	6	6mm Hex Nuts

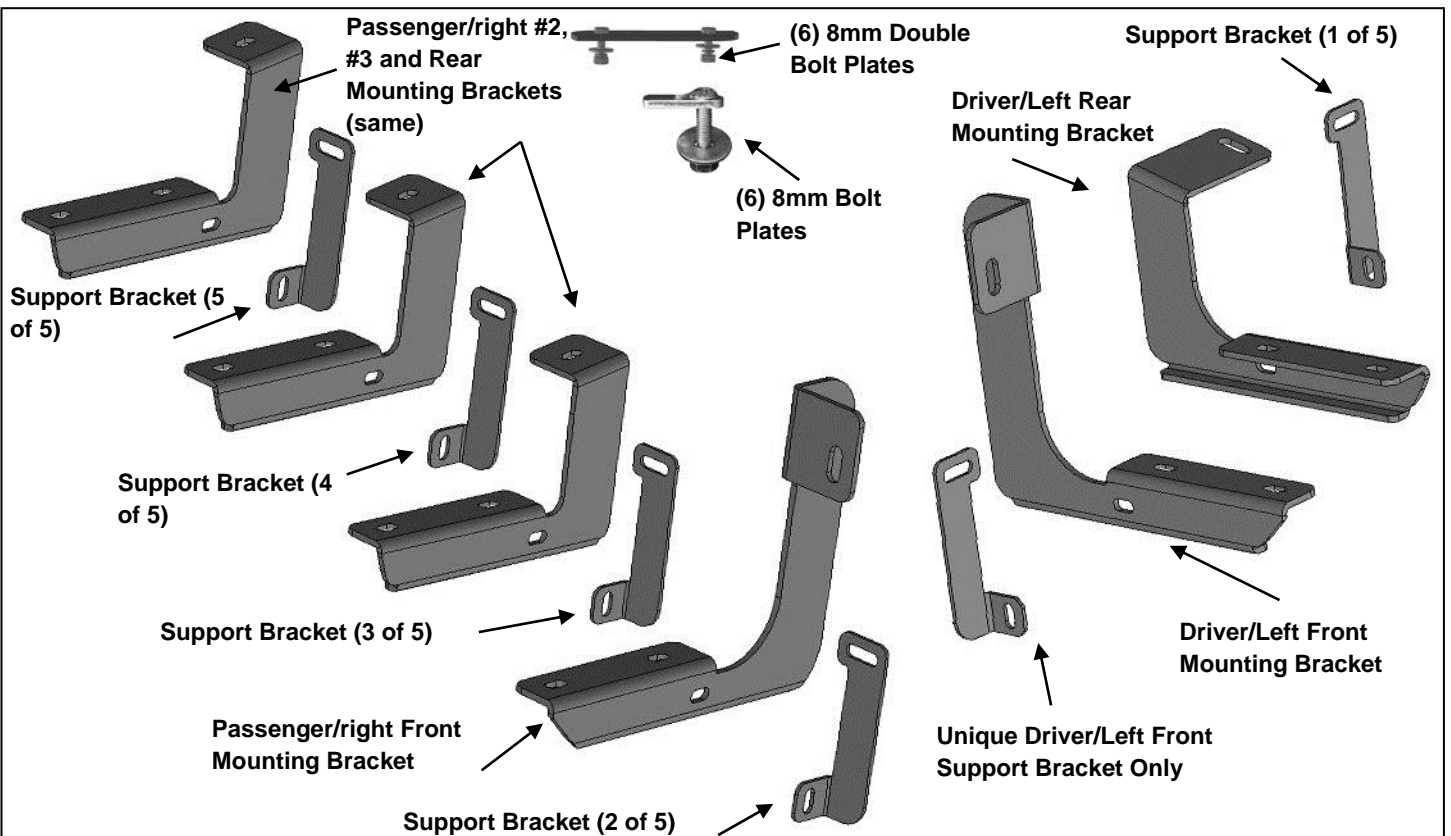

INSTALLATION PROCEDURE:

1. Start the installation under the driver side of the vehicle. Locate the factory hole in the side of the inner body panel, **(Figures 1 & 3)**. **IMPORTANT:** Hole may be covered with rubber plug, sealing tape and/or heavy undercoating. Remove excess undercoating from all mounting locations so that Brackets will install flat against body panel and pinch weld.
 2. Select (1) 8mm Bolt Plate and (1) 8mm Plastic Retainer, **(Figure 2)**. Thread the Retainer part way onto the Bolt Plate. Insert the Bolt Plate into the hole and tighten the Retainer against the body panel, **(Figure 3)**. **IMPORTANT:** The Plastic Retainer is designed to prevent the Bolt Plate from falling into the body panel and to aid in Bracket installation.
 3. Select the driver/left front Mounting Bracket. Attach the Bracket to the Bolt Plate with (1) 8mm x 28mm Large Flat Washer, (1) 8mm Lock Washer and (1) 8mm Hex Nut, **(Figures 4 & 5)**. Leave hardware loose at this time.
 4. Select the unique driver/left front Support Bracket, **(Figures 4 & 5)**. Attach the Support Bracket to the front of the Mounting Bracket with (1) 8mm x 25mm Hex Bolt, (2) 8mm x 16mm Small Flat Washers and (1) 8mm Nylon Lock Nut. Line up the top of the Support Bracket with the back of the pinch weld. Scrape off excess sealant as necessary to attach Support Bracket flat against body panel, **(Figure 5)**. Snug but do not fully tighten hardware at this time.
 5. Move to the driver/left rear mounting location. Locate the hole in the bottom of the floor panel, **(Figure 6)**. Repeat **Steps 1—4** to attach the driver/left rear Bracket to the 8mm Bolt Plate, **(Figures 7 & 8)**.
 6. Select (1) of the (5) identical Support Brackets, **(Figure 7)**. Attach the Support Bracket to the back of the rear Mounting Bracket with (1) 8mm x 25mm Hex Bolt, (2) 8mm x 16mm Small Flat Washers and (1) 8mm Nylon Lock Nut, **(Figure 7 & 8)**. Line up the top of the Support Bracket with the back of the pinch weld. Snug but do not fully tighten hardware at this time.
 7. Carefully unwrap the Running Boards. Place the shorter driver side Running Board on top of the (2) Brackets. Select (2) 8mm Double Bolt Plates, **(Figure 9)**. Locate the channels in the bottom of the Running Board. Insert the Bolt Plates into the channels closest to the Brackets. Lift the Running Board up and guide the studs down through the Brackets.
 8. Attach the Running Board to the Brackets with (4) 8mm x 24mm STD Flat Washers, (4) 8mm Lock Washers and (4) 8mm Hex Nuts, **(Figure 10)**. **NOTE:** The Running Board is designed to fit close to the vehicle. It may be necessary to loosen the Bracket hardware and tilt the Brackets downward to insert the Running Board between the Brackets and the body. Do not tighten hardware at this time.
 9. Level and adjust the Running Board and tighten the Bracket to Bolt Plate hardware only. Remove the Running Board. Adjust the Support Brackets as necessary to move the top of the Brackets up to touch the bend in the pinch weld. Scrape off excess sealant as required. Mark the location of the (2) slots in the Support Brackets onto the back of the pinch weld, **(Figures 5 & 8)**.
 10. Use a 1/4" drill bit to drill (2) holes through the pinch weld for the front and rear Support Brackets, **(Figures 11 & 12)**. **NOTE:** Drill the holes as far away from the bottom edge of the pinch weld as possible. **IMPORTANT:** Do not drill through the welds in the pinch weld if possible.
- IMPORTANT!** Any cutting or drilling tool may break or shatter. Government regulations require safety glasses & equipment at all times when cutting or drilling.
11. Attach the top of the Support Brackets to the back of the pinch weld with (2) 6mm x 25mm Hex Bolts, (4) 6mm Flat Washers, (2) 6mm Lock Washers and (2) 6mm Hex Nuts, **(Figures 11 & 12)**. Reinstall the Running Board. Level, adjust and tighten all hardware.
 12. Move to the passenger side of the vehicle, **(Figure 13)**. Repeat **Steps 1—3** to attach the passenger side front Bracket, **(Figures 14 & 15)**. Repeat **Step 6** to attach (1) of the (5) identical Support Brackets.
 13. Continue to the #2 mounting location, **(Figure 16)**. Repeat **Steps 5 & 6** to attach the #2 Mounting Bracket, **(Figure 16—18)**. Repeat to install the #3 and #4 (rear) Brackets, **(Figure 19)**.
 14. Select the long passenger side running board. Select (4) 8mm Double Bolt Plates, **(Figure 9)**. Locate the channels in the bottom of the Running Board, **(Figure 9)**. Insert the Bolt Plates into the channels closest to the Brackets. Lift the Running Board up and guide the studs through the Brackets.
 15. Attach the Running Board to the Brackets with (8) 8mm x 24mm STD Flat Washers, (8) 8mm Lock Washers and (8) 8mm Hex Nuts, **(Figure 10)**.
 16. Level and adjust the Running Board and tighten the Bracket to Bolt Plate hardware only. Temporarily remove the Running Board.
 17. Repeat **Steps 9—11** to mark, drill and attach the (4) Support Brackets to the pinch weld, **(Figures 18 & 19)**.
 18. Reinstall the Running Board. Level and adjust and tighten all hardware.
 19. Do periodic inspections to the installation to make sure that all hardware is secure and tight.

Driver/left Side Installation Pictured

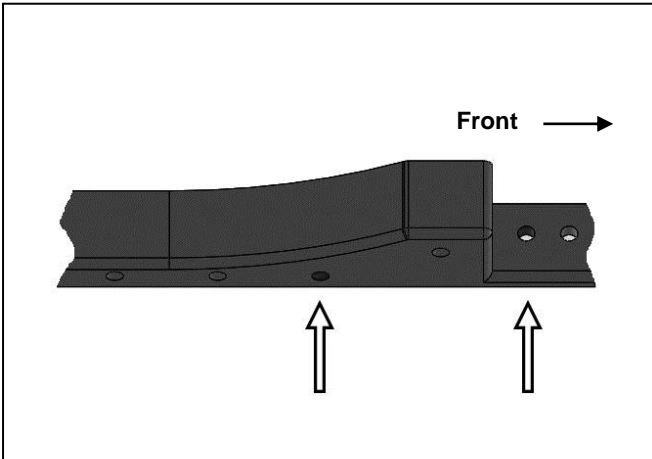

(Fig 1) Driver side front and rear mounting locations

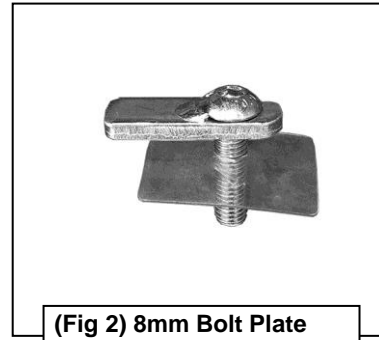

(Fig 2) 8mm Bolt Plate with Plastic Retainer

- 8mm Bolt Plate
- 8mm Plastic Retainer
- 8mm Large Flat Washer
- 8mm Lock Washer
- 8mm Hex Nut

NOTE: Unique driver side front Support Bracket

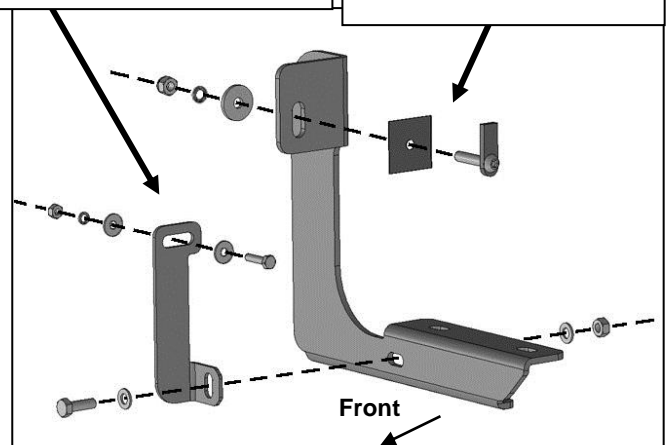

(Fig 4) Driver/left front Brackets illustrated

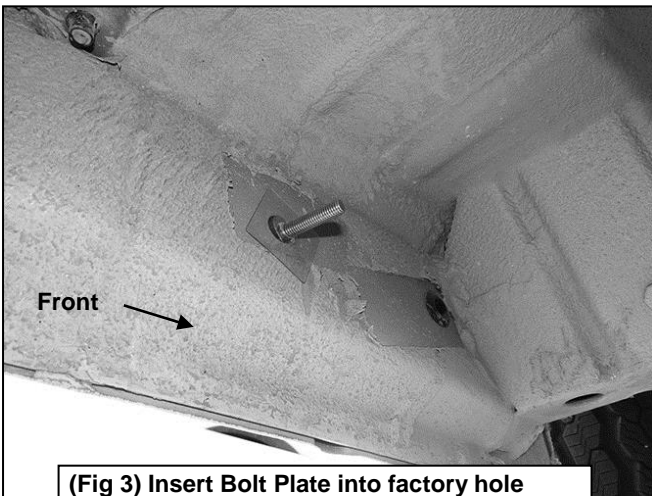

(Fig 3) Insert Bolt Plate into factory hole

Driver/left Side Installation Pictured

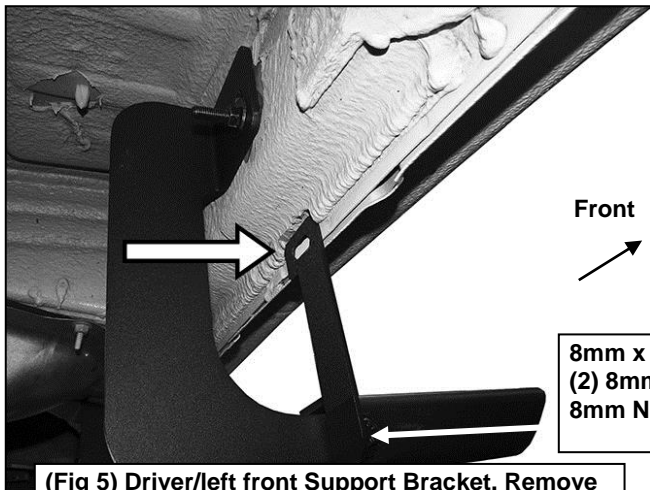

(Fig 5) Driver/left front Support Bracket. Remove sealant if necessary (arrow) to allow bracket to sit flat against body panel

- 8mm x 25mm Hex Bolt
- (2) 8mm Small Flat Washers
- 8mm Nylon Lock Nut

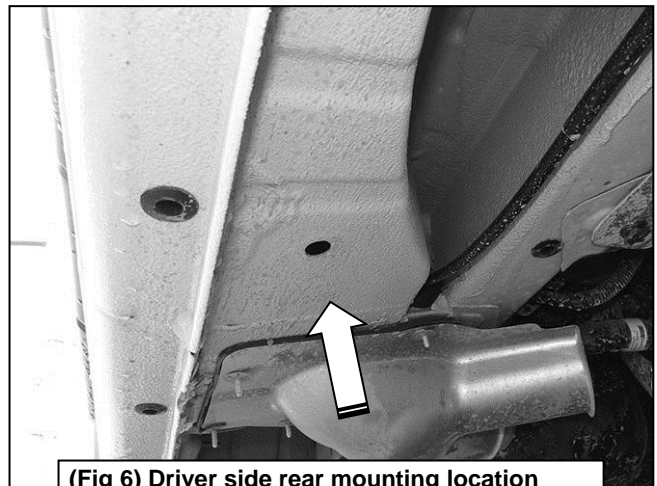

(Fig 6) Driver side rear mounting location

8mm x 25mm Hex Bolt
 (2) 8mm Small Flat Washers
 8mm Nylon Lock Nut

8mm Bolt Plate
 8mm Plastic Retainer
 8mm Large Flat Washer
 8mm Lock Washer
 8mm Hex Nut

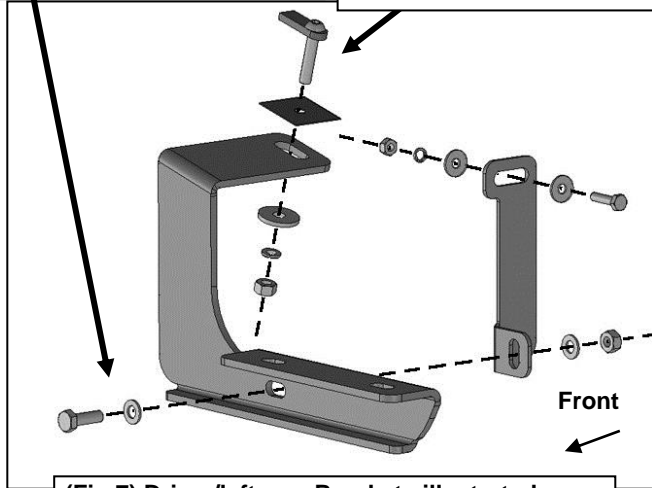

(Fig 7) Driver/left rear Brackets illustrated

Driver side rear Support
 Bracket (1 of 5)

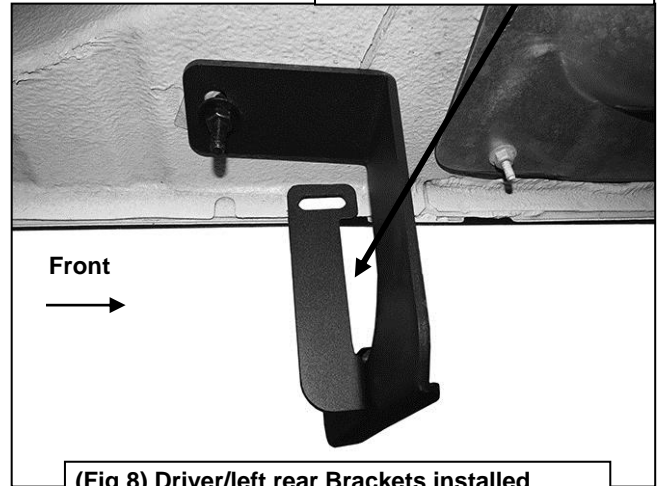

(Fig 8) Driver/left rear Brackets installed

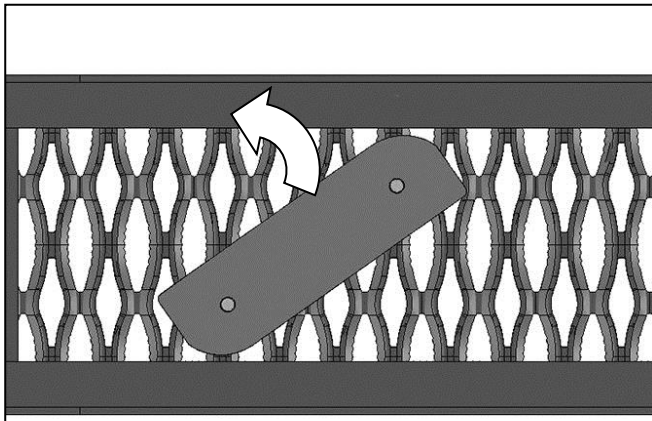

(Fig 8) Insert 8mm Double Bolt Plates into tracks on the bottom of the Running Board

(2) 8mm x 24mm STD Flat Washers
 (2) 8mm Lock Washers
 (2) 8mm Hex Nuts

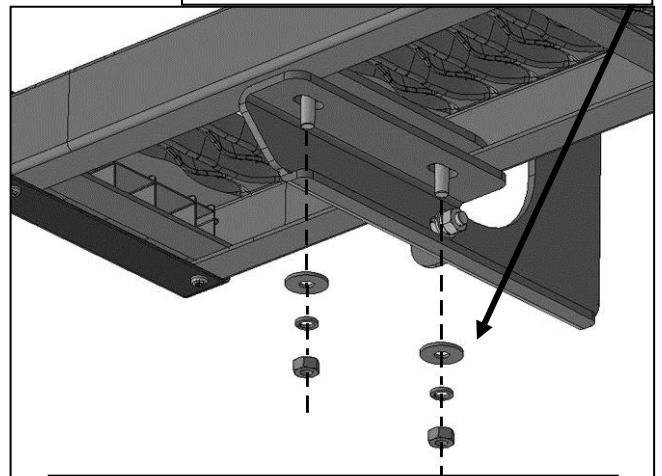

(Fig 9) Attach Running Board to Brackets

Driver/left Side Installation Pictured

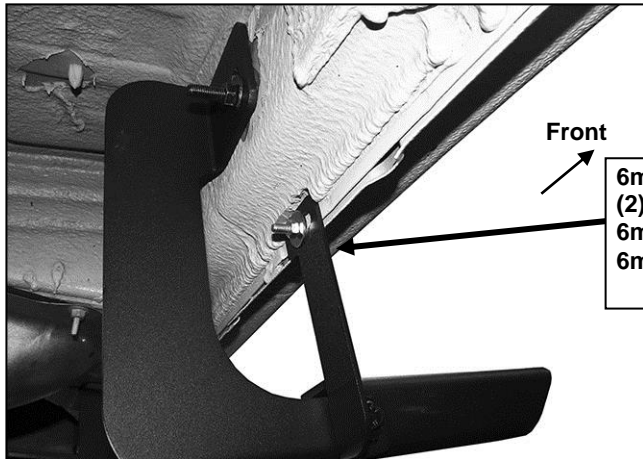

Level and adjust the Running Board.
Temporarily remove the running board only.
Mark and drill 1/4" hole through pinch weld
for each Support Bracket

6mm x 25mm Hex Bolt
(2) 6mm Flat Washers
6mm Lock Washer
6mm Hex Nut

(Fig 10) Mark and drill hole through pinch weld. Attach top of Driver/left front Support Bracket to back of pinch weld. Reinstall Running Board



(Fig 11) Mark and drill hole through pinch weld. Attach top of Driver/left rear Support Bracket to back of pinch weld. Reinstall Running Board

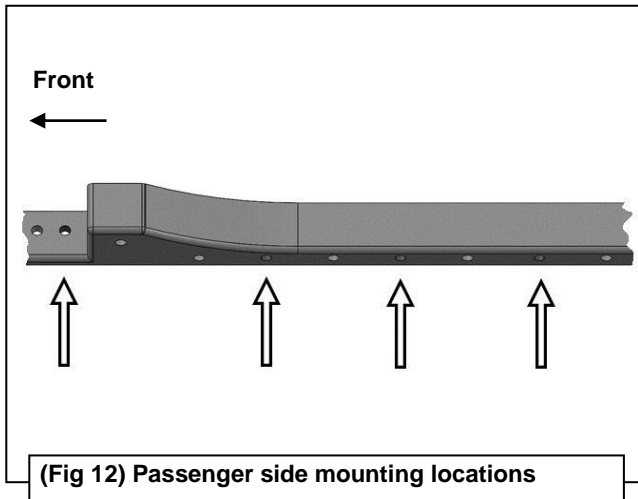

(Fig 12) Passenger side mounting locations

8mm Bolt Plate
Plastic Retainer

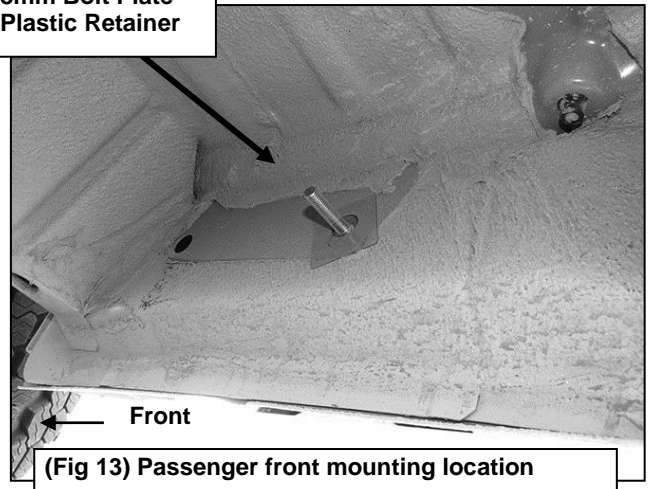

(Fig 13) Passenger front mounting location

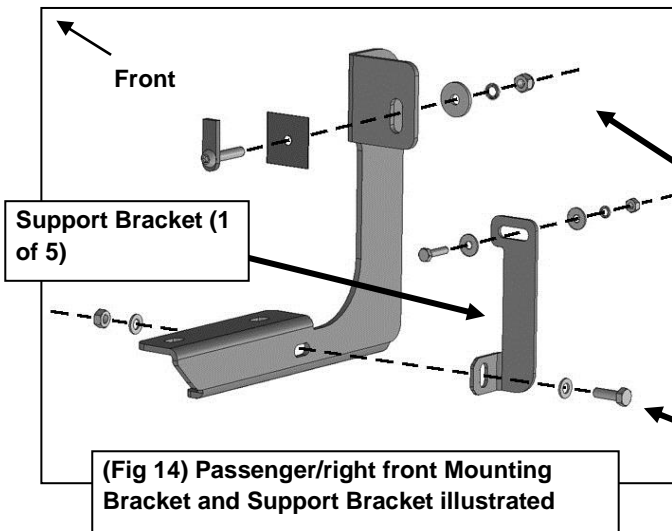

8mm Bolt Plate
8mm Plastic Retainer
8mm Large Flat Washer
8mm Lock Washer
8mm Hex Nut

8mm x 25mm Hex Bolt
(2) 8mm Small Flat Washers
8mm Nylon Lock Nut

(Fig 14) Passenger/right front Mounting Bracket and Support Bracket illustrated

Passenger/right Side Installation Pictured

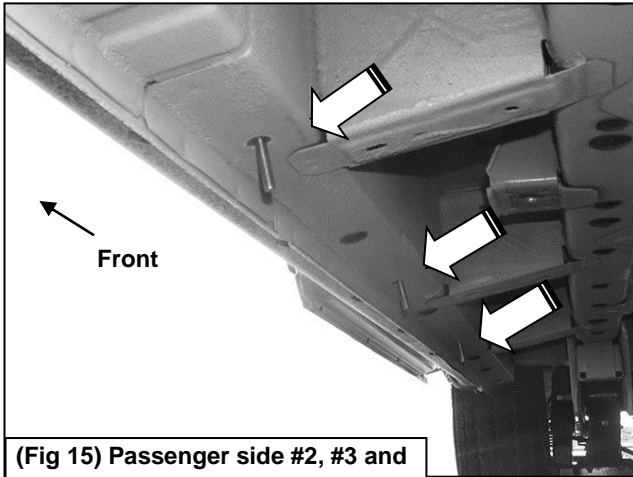

(Fig 15) Passenger side #2, #3 and rear mounting locations

- 8mm Bolt Plate
- 8mm Plastic Retainer
- 8mm Large Flat Washer
- 8mm Lock Washer
- 8mm Hex Nut

Support Bracket (1 of 5)

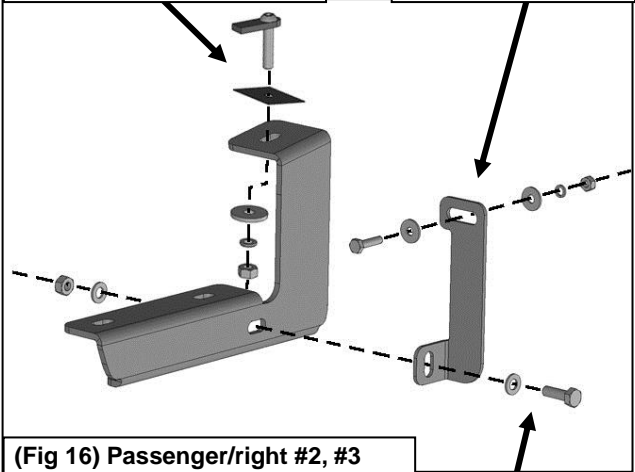

(Fig 16) Passenger/right #2, #3 and rear Brackets illustrated

- 6mm x 25mm Hex Bolt
- (2) 6mm Flat Washers
- 6mm Lock Washer
- 6mm Hex Nut



(Fig 17) Passenger/right side #2 Brackets installed

- 8mm x 25mm Hex Bolt
- (2) 8mm Small Flat Washers
- 8mm Nylon Lock Nut

- 6mm x 25mm Hex Bolt
- (2) 6mm Flat Washers
- 6mm Lock Washer
- 6mm Hex Nut

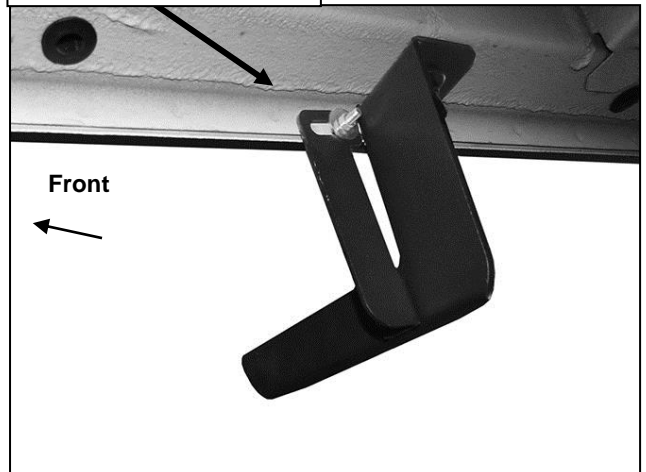

(Fig 18) Passenger/right side #3 Brackets installed



Complete Passenger Side Installation

PARTS IDENTIFICATION GUIDE

Driver Side tube packed using "Green" color foam sheet. Passenger Side tube packed using "White" color foam sheet

No.	Parts Identification
1	Passenger / Right 'Rear' Bracket marked "PR"
2	Driver / Left 'Rear' Bracket marked "DR"
3	Passenger / Right 'Center' Bracket marked "PC"
4	Driver / Left 'Center' Bracket marked "DC"
5	Passenger / Right 'Front' Bracket marked "PF"
6	Driver / Left 'Front' Bracket marked "DF"

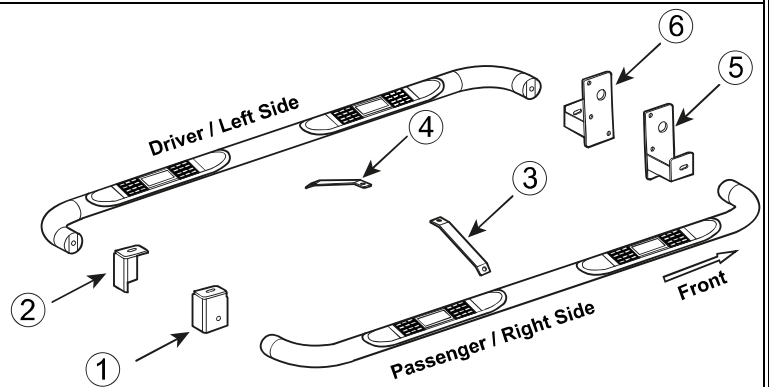

Note:

- This guide is to identify the parts and not a reference for part count.
- For part count, refer Parts List.
- Product / Bracket image is representative and actual design may vary.

PRODUCT CARE

- Periodically check the product to ensure all fasteners are tight and components are intact.
- Regular waxing is recommended to protect the finish of the product.
- **Use ONLY Non-Abrasive automotive wax.** Use of any soap, polish or wax that contains an abrasive is detrimental and can scratch the finish leading to corrosion.
- Aluminum polish may be used to polish small scratches and scuffs for **Stainless Steel finish.**
- Mild soap may be used to clean the product for both **Stainless Steel and Black finish.**

FAQ's

1. Hardware's are not of correct size.

In GMC / Chevrolet truck model 2006 & up, customer needs to reuse the factory body bolts to install the bracket. If your vehicle is not GMC / Chevrolet 2006 & up, ensure that holes are not partially covered with any plastic grommet or rust? If it is, remove the plastic grommet & rust from the thread holes & re-try the installation.

2. Mounting Bracket are not getting Installed properly.

In some cases Illustration images shown in Installation manual may not be the exactly same as per actual vehicle images ,also if Driver / Passenger side mounting brackets are very identical in the design, suggest referring Parts Identification guide to avoid fitment issue.

3. Products are thumping / rattling after installation.

Ensure that all required mounting brackets / hardware's are installed & tighten correctly. Suggest using white lithium / regular grease between the metal to metal contact surfaces.

4. Side Bar is not aligning with vehicle / Step Pads are not aligning with vehicle doors.

Side bar may be interchanged or mounting brackets are not installed at the correct position in the vehicle. Refer Parts identification guide.

5. Missing / Excess Hardware.

Recheck hardware count as per the part list.

6. Product not installing properly.

Ensure make model year, cab length and bed size of your vehicle is listed in the application. All installation steps are followed correctly.

Check out these other TrailFX Products!!

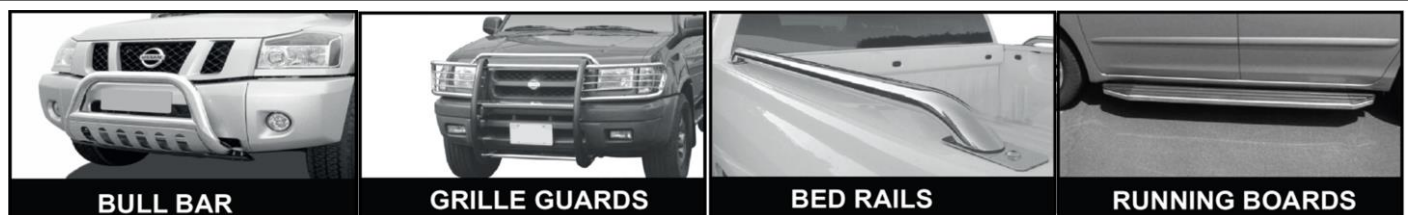

BULL BAR

GRILLE GUARDS

BED RAILS

RUNNING BOARDS

Keystone Automotive Operations Inc. (KAO) warrants this product to be free of defects in material and workmanship at the time of purchase by the original retail consumer. KAO disclaims any other warranties, express or implied, including the warranty of fitness for a particular purpose or an intended use. If the product is found to be defective, KAO may replace or repair the product at our option, when the product is returned prepaid, with proof of purchase. Alteration to, improper installation, or misuse of this product voids the warranty. KAO's liability is limited to repair or replacement of products found to be defective, and specifically excludes liability for any incidental or consequential loss or damage.