

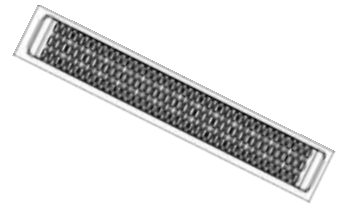

Aggressive Running Board-Van

Part No. ARBV001B



Fits: 2015 - Current

Ford Transit (32"+96")



FULL SIZE



REMOVE CONTENTS FROM BOX. VERIFY ALL PARTS ARE PRESENT.



READ INSTRUCTIONS CAREFULLY BEFORE STARTING INSTALLATION.

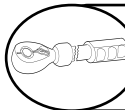

DO NOT OVER TORQUE. STANDARD OPERATING LOAD FOR TIGHTEN BODY MOUNT NUTS & BOLTS VARIES FROM 45 TO 65 FOOT POUND.



60-180 min



Cutting may be Required



Drilling Required

PARTS LIST:

Qty	Part Description	Qty	Part Description
1	Aggressive DS Running Board 32"	1	8mm Insert Nut
1	Aggressive PS Running Board 96"	1	8-1.25mm x 35mm Hex Bolt
1	Driver/Left Side Rear Mounting Bracket	13	8-1.25mm x 25mm Hex Bolt
5	Passenger/Right Side Mounting Brackets	32	8mm x 24mm x 2mm Flat Washers
2	10-1.5mm x 35mm Bolt Plates	25	8mm Lock Washers
2	10mm Plastic Retainer	12	8mm "U" Clips
4	10mm x 30mm x 2mm Flat Washers	13	8mm Hex Nuts
2	10mm Nylon Lock Hex Nuts	6	8mm Nylon Lock Hex Nuts
3	8mm U-Bolts	6	8mm Double Bolt Plates
1	8mm Insert Tool		

(6) 8mm Double Bolt Plates

(2) 10mm x 35mm Bolt Plates (use for passenger side front and rear brackets only)

(2) 10mm Plastic Retainers (use with Bolt Plates)

(3) 8mm U-Bolts (use for driver side rear and passenger side #2 and #3 brackets only)

(1) 8mm Threaded Insert Tool and Insert (use with driver side front only)

(5) Mounting Brackets (use for all passenger side and driver side front only)

Front

Driver/Left Rear Mounting Bracket

INSTALLATION PROCEDURE:

1. Start the installation under the passenger side of the vehicle. Release the lower clips from the plastic trim along the bottom of the body, **(Figure 1)**. **NOTE:** From below, insert a small or medium sized flat blade screwdriver into the rectangular hole in the center of the clip. Carefully release each side (inside to outside, not front to back) of the plastic clip and pull the rectangular center pin down from the clip, **(Figure 2)**. Do not twist the clip, gently pull it straight down once it is released. It is not necessary to completely remove the trim, only release the clips attaching the bottom of the trim to the vehicle.
2. Locate the factory hole approximately 24" back from the front of the body, **(Figure 3)**. Remove excess undercoating from all mounting locations so that Brackets will install flat against body panel and pinch weld.
3. Select (1) 10mm Bolt Plate, (1) 10mm Flat Washer and (1) 10mm Plastic Retainer, **(Figure 4)**. Thread the Retainer part way onto the Bolt Plate. Insert the Bolt Plate into the hole and tighten the Retainer against the body panel. Slide the 10mm Flat Washer onto the end of the Bolt Plate, **(Figure 5)**. **IMPORTANT:** The Plastic Retainer is designed to prevent the Bolt Plate from falling into the body panel and to aid in Bracket installation.
4. Select (1) passenger side Mounting Bracket. Line up the long slot in the center of the Bracket with the Bolt Plate and Flat Washer. Attach the Bracket to the Bolt Plate with (1) 10mm Flat Washer and (1) 10mm Nylon Lock Hex Nut, **(Figure 6)**. Push the Bracket up tight against the bottom of the body and temporarily tighten.
5. Mark the location of the (2) bottom slots in the Bracket onto the pinch weld, **(Figure 6)**. **IMPORTANT:** Do not drill through the welds in the pinch weld. Slide the Bracket forward or back to move the slots away from the factory spot welds. Do not drill into or through the outer plastic rocker panel cover. Remove the Bracket. Use a 3/8" drill bit to drill (2) holes through the pinch weld only. **NOTE:** Drill the holes as far away from the bottom edge of the pinch weld as possible.

IMPORTANT! Any cutting or drilling tool may break or shatter. Government regulations require safety glasses & equipment at all times when cutting or drilling.

6. Select (2) 8mm U-Clips. Slide the U-Clips over the pinch weld with the nut toward the outside, **(Figure 7)**. Reattach the Bracket to the Bolt Plate, **(Step 4)**. Attach the Bracket to the pinch weld with (2) 8mm x 25mm Hex Bolts, (2) 8mm Lock Washers and (2) 8mm Flat Washers, **(Figure 8)**. Leave hardware loose at this time.
7. Move along the body to the 2nd mounting location. Determine if the vehicle is equipped with factory mounting studs along the body panel.

Models without factory studs:

- a. Locate the (2) factory holes in the side of the body panel, **(Figure 9)**. Insert (1) 8mm U-Bolt into and through the (2) holes, **(Figure 10)**. Thread 8mm Plastic Retainers onto the ends of the U-Bolt to hold it in place. Select (1) Passenger side Bracket.
- b. Attach the Bracket to the U-Bolt with (2) 8mm Flat Washers and (2) 8mm Nylon Lock Hex Nuts, **(Figures 11 & 12)**.
- c. Repeat **Steps 5 & 6** to drill and attach the bottom of the Bracket to the back of the pinch weld, **(Figure 15)**.
Repeat to install (1) Bracket in the 3rd mounting location, **(Figures 13 & 15)**.

Models with factory studs:

- a. Attach (1) passenger side Bracket to the factory studs with (2) 8mm Flat Washers and (2) 8mm Nylon Lock Hex Nuts, **(Figures 14 & 15)**.
 - b. Repeat **Steps 5 & 6** to drill and attach the bottom of the Bracket to the back of the pinch weld.
 - c. Repeat to install (1) Mounting Bracket in the 3rd mounting location.
8. Continue along the side of the vehicle to the 4th mounting location, **(Figure 16)**. Repeat **Steps 2—6** to install (1) passenger side Mounting Bracket in the 4th (last) mounting location, **(Figures 17 & 18)**.
 9. Select the long passenger side Running Board. Place the Running Board on top of the (4) Brackets. Select (4) 8mm Double Bolt Plates. Locate the channels in the bottom of the Running Board, **(Figure 19)**. Insert the Bolt Plates into the channels in the bottom of the Running Board closest to the Brackets. Lift the Running Board up and guide the studs through the Brackets.
 10. Attach the Running Board to the Brackets with (8) 8mm Flat Washers, (8) 8mm Lock Washers and (8) 8mm Hex Nuts, **(Figure 20)**. **NOTE:** The Running Board is designed to fit close to the vehicle. It may be necessary to loosen the Bracket hardware and tilt the Brackets downward to insert the Running Board between the Brackets and the body. Do not tighten hardware at this time.

11. Level and adjust the Running Board and fully tighten all hardware. Reinstall the plastic trim along the bottom of the body. **IMPORTANT:** Minor trimming may be required around 8mm U-Clips. Temporarily remove the Running Board. Use a sharp knife or hacksaw blade to trim plastic as required.
12. Move to the driver side of the vehicle. Repeat **Step 1, (Figures 1 & 2)**, to release the clips attaching the plastic trim to the bottom of the driver side. Identify the front bracket mounting location approximately 10" back from the front corner of the body, (**Figure 21**).
13. Select (1) passenger/driver side front Bracket. Hold the Bracket firmly in position against the bottom and side of the body panel and mark the top left hole location onto the inner body panel. Also mark the (2) lower mounting locations onto the back of the pinch weld, (**Figure 21**). **IMPORTANT:** Do not drill through the welds in the pinch weld. Slide the Bracket forward or back to move the slots away from the factory spot welds. Do not drill into or through the outer plastic rocker panel cover.
14. Move the Bracket out of the way and drill a 7/16" hole through the body panel for the top of the Bracket, (**Figures 21 & 24B**). Select (1) 8mm Threaded Insert, (1) 8mm x 35mm Hex Bolt, (1) 8mm Hex Nut, (1) 8mm Flat Washer and (1) 8mm Insert Tool. Thread the Hex Nut onto the Hex Bolt. Assemble the Tool as pictured in **Figure 22**. Use a 13mm wrench to hold the Hex Bolt to prevent it from spinning. Turn the Hex Nut counter-clockwise to pull/expand the insert in the hole, (**Figure 23**). Tighten the Hex Nut until the Insert is fully installed, (**Figures 24A & 24B**). Do not overtighten the Hex Nut.
15. Next, repeat **Steps 5 & 6** to drill the pinch weld and attach the bottom of the Bracket to the pinch weld, (**Figures 24B & 25**). Attach the top of the Bracket to the previously installed Threaded Insert with (1) 8mm x 25mm Hex Bolt, (1) 8mm Lock Washer and (1) 8mm Flat Washer, (**Figure 25**). Leave hardware loose at this time.
16. Continue along the side of the body to the driver side rear mounting location approximately 24" back from the front corner of the body, (**Figures 21 & 26**). Select the unique driver side rear Mounting Bracket. Hold the Bracket firmly against the bottom and back of the body panel. Slide the Bracket forward or back as necessary to avoid drilling through any welds on the pinch weld. Mark all (4) locations to drill.
17. Drill (2) 7/16" holes through the bottom of the body panel as marked, (**Figure 27**). Next, repeat **Step 5** to drill through the pinch weld to attach the bottom of the Bracket. Insert (1) 8mm U-Bolt into and through the (2) drilled 7/16" holes. Select (1) Passenger side Bracket. Attach the top slots on the Bracket to the U-Bolt with (2) 8mm Flat Washers and (2) 8mm Nylon Lock Hex Nuts, (**Figure 28**). Repeat **Step 6** to drill and attach the bottom of the Bracket to the back of the pinch weld. Leave all hardware loose at this time.
18. Select the driver side Running Board. Place the Running Board on top of the (2) Brackets. Select (2) 8mm Double Bolt Plates. Repeat **Steps 10 & 11** to attach the Running Board to the (2) Brackets.
19. Level and adjust the Running Board and fully tighten all hardware. Reinstall the plastic trim along the bottom of the body. **IMPORTANT:** Minor trimming may be required around 8mm U-Clips. Use a sharp knife or hacksaw blade to trim plastic as required.
20. Do periodic inspections to the installation to make sure that all hardware is secure and tight.

Passenger/right Side Installation Pictured

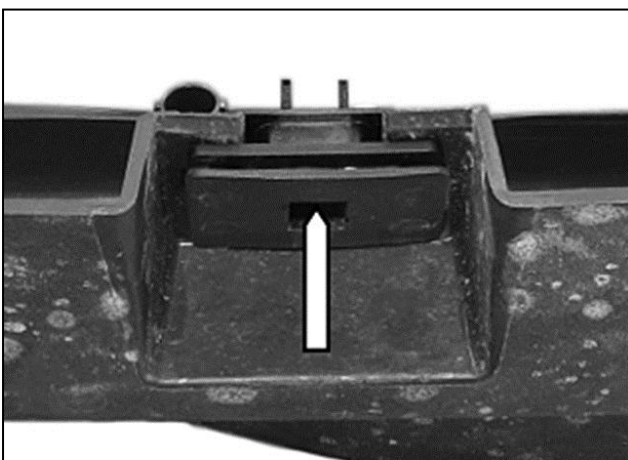

(Fig 1) Insert flat blade screwdriver into square opening in center of plastic clip to release

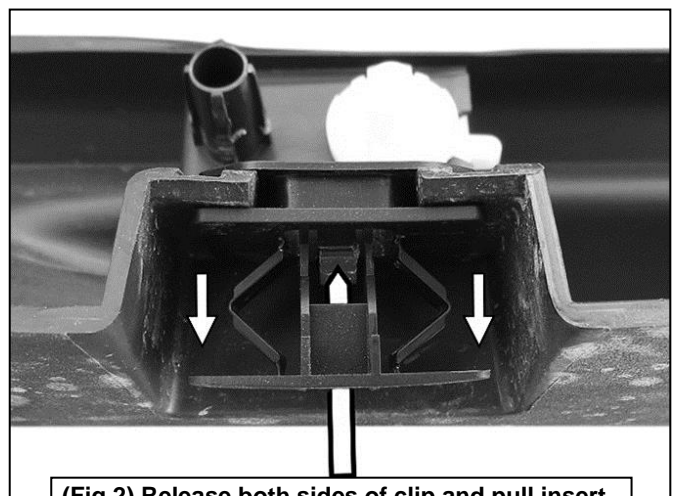

(Fig 2) Release both sides of clip and pull insert to release. Do not try to pull the clip out of the trim, only release clip as pictured

Passenger/right Side Installation Pictured

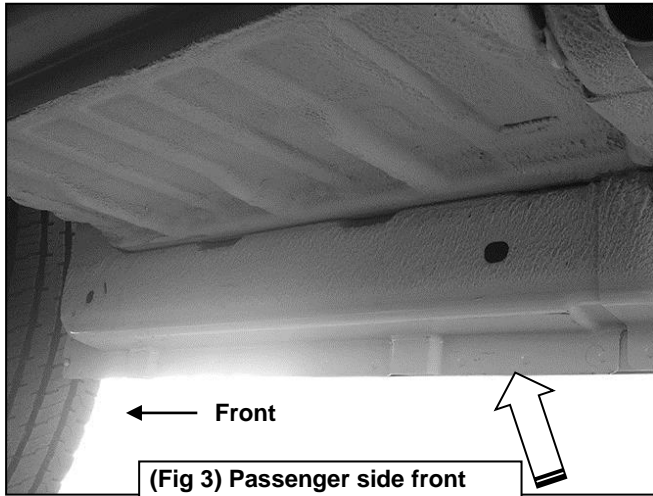

(Fig 3) Passenger side front mounting location pictured



(Fig 4) Bolt Plate with Plastic Retainer

(2) 10mm Flat Washers
(1) 10mm Nylon Lock Hex Nuts

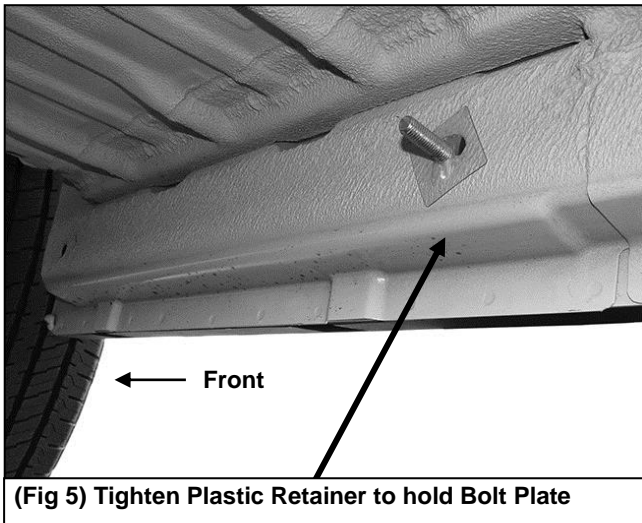

(Fig 5) Tighten Plastic Retainer to hold Bolt Plate

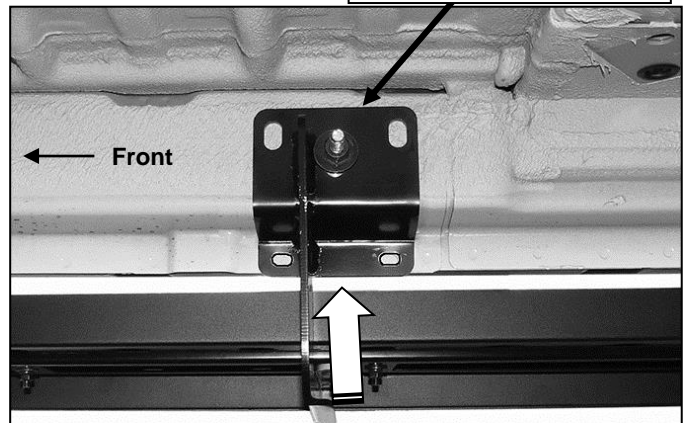

(Fig 6) Push Bracket up tight against body panel. Mark location of bottom slots onto pinch weld

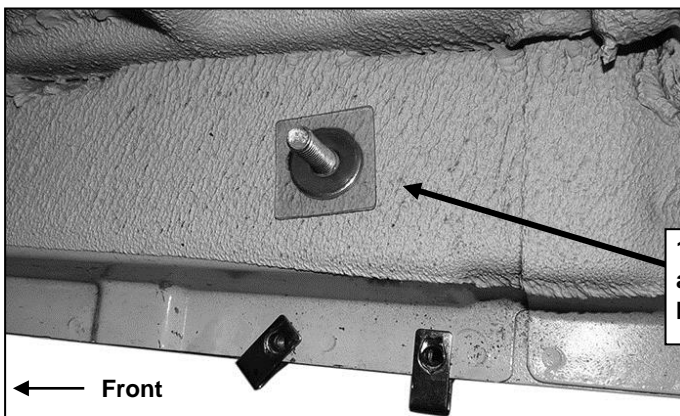

10mm Flat Washer installed as a spacer between Bracket and body

(Fig 7) Drill 3/8" holes through pinch weld. Slide 8mm U-Clip onto pinch weld over holes

Passenger/right Side Installation Pictured

(2) 10mm Flat Washers
(1) 10mm Nylon Lock Hex Nuts

(2) 8mm x 25mm Hex Bolts
(2) 8mm Lock Washers
(2) 8mm Flat Washers

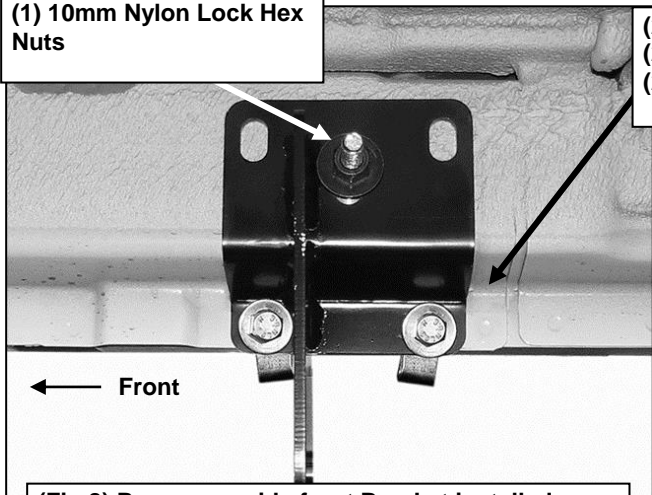

(Fig 8) Passenger side front Bracket installed

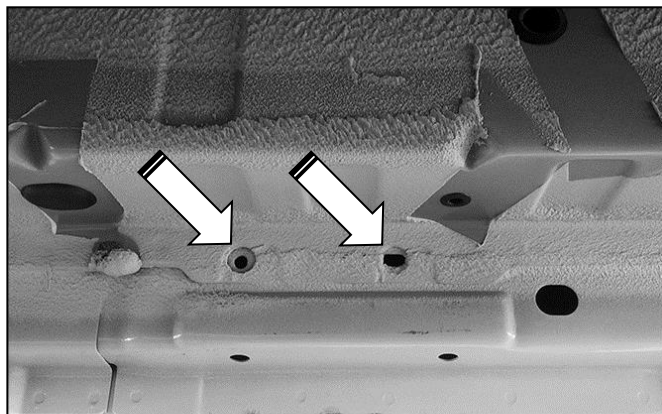

(Fig 9) Locate the #2 mounting location for Bracket. Insert 8mm U-Bolt into and out factory holes in body panel

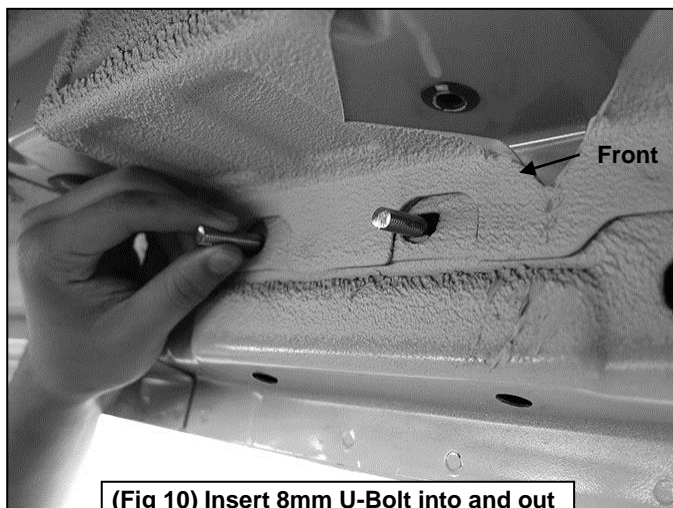

(Fig 10) Insert 8mm U-Bolt into and out factory holes in body panel

(1) 8mm U-Bolt
(2) 8mm Flat Washers
(2) 8mm Nylon Lock Hex Nuts

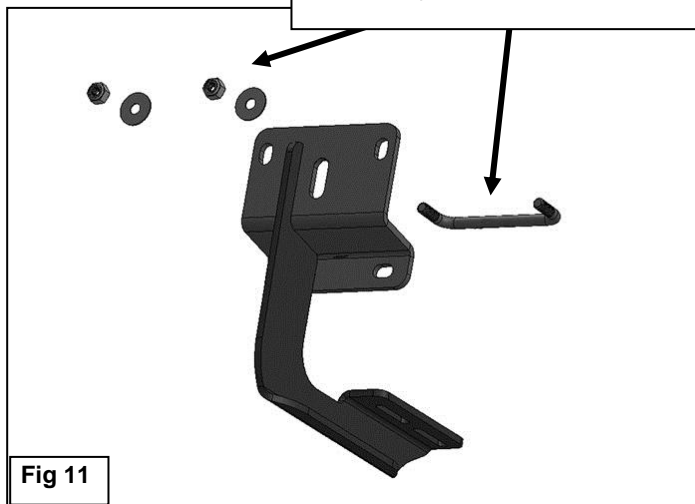
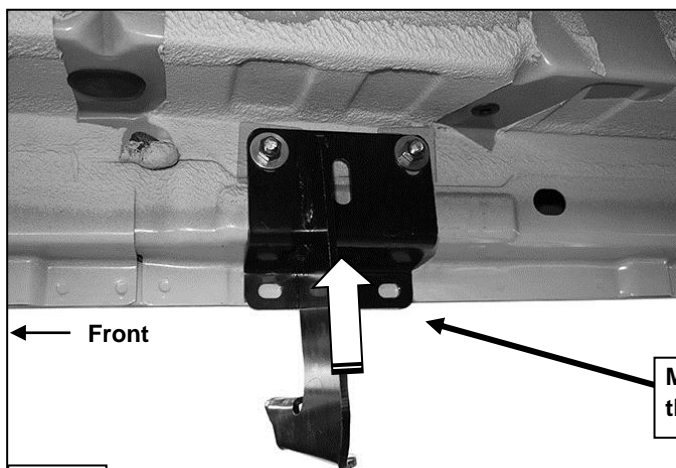

Fig 11



Mark and drill 3/8" holes through pinch weld

Fig 12

Passenger/right Side Installation Pictured

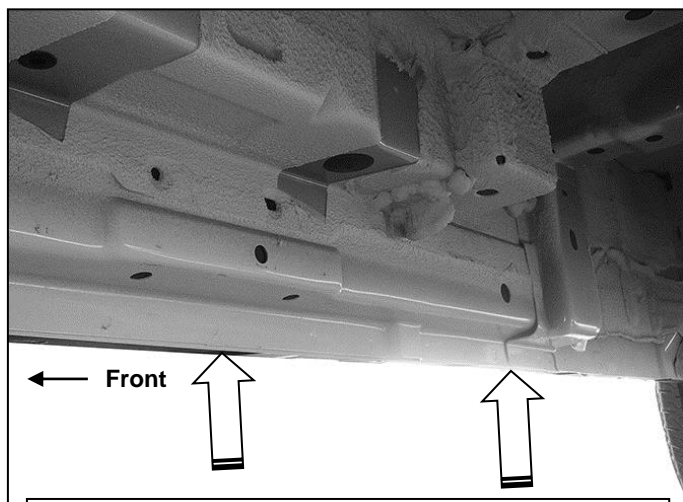

(Fig 13) #3 and rear mounting locations pictured

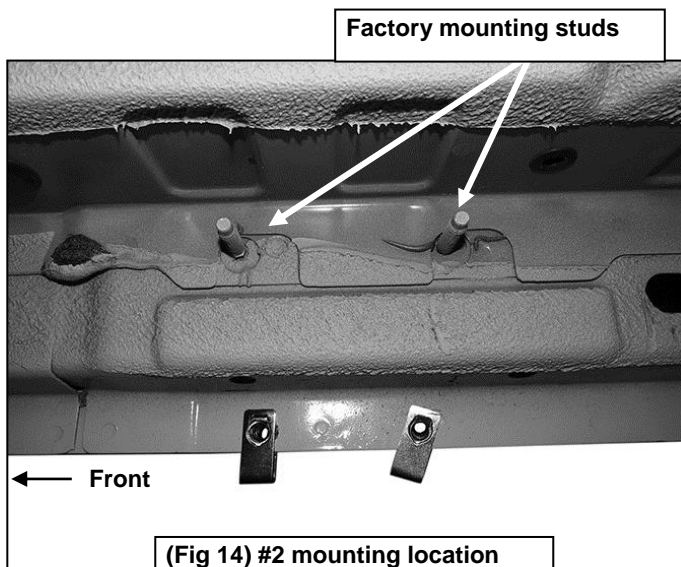

(Fig 14) #2 mounting location with factory mounting studs

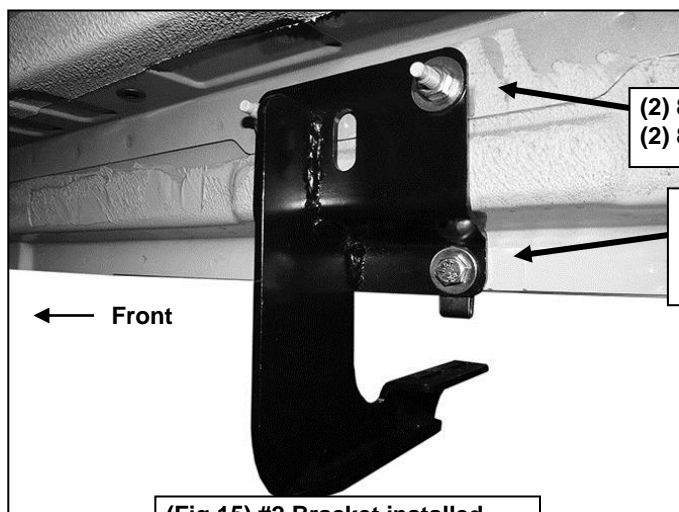

(Fig 15) #2 Bracket installed

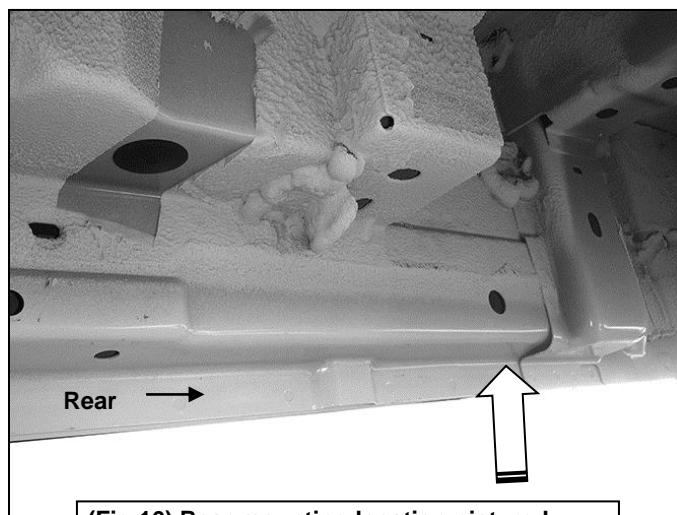

(Fig 16) Rear mounting location pictured

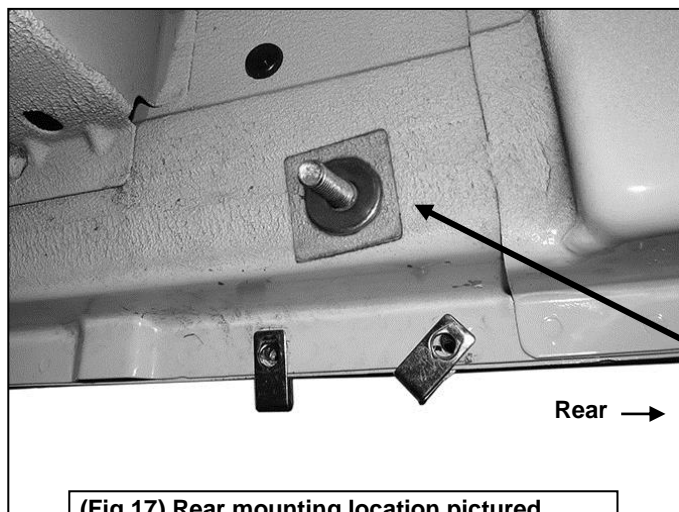

(Fig 17) Rear mounting location pictured

10mm Flat Washer installed as a spacer between Bracket and body

Passenger/right Side Installation Pictured

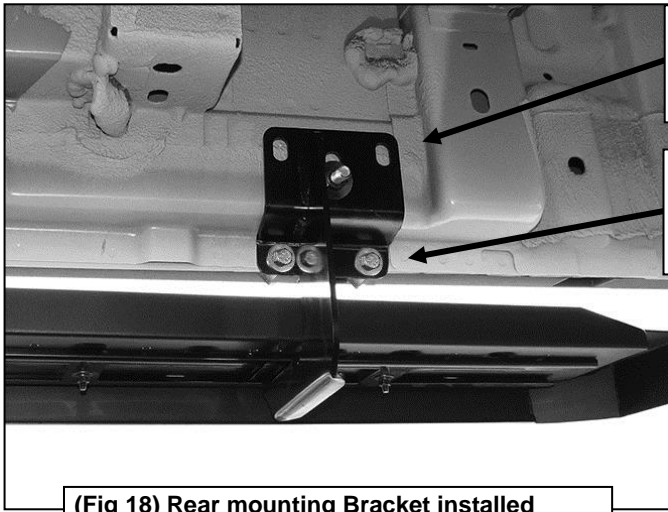

(2) 10mm Flat Washers
(1) 10mm Nylon Lock Hex Nut

(2) 8mm x 25mm Hex Bolts
(2) 8mm Lock Washers
(2) 8mm Flat Washers

(Fig 18) Rear mounting Bracket installed

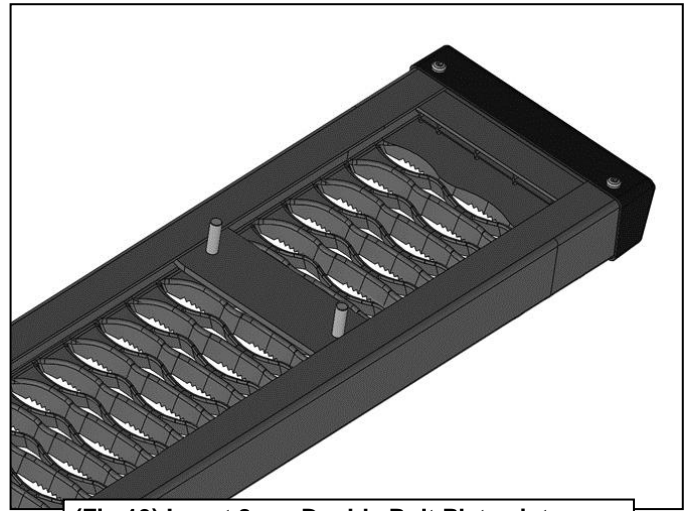

(Fig 19) Insert 8mm Double Bolt Plates into tracks on the bottom of the Running Board

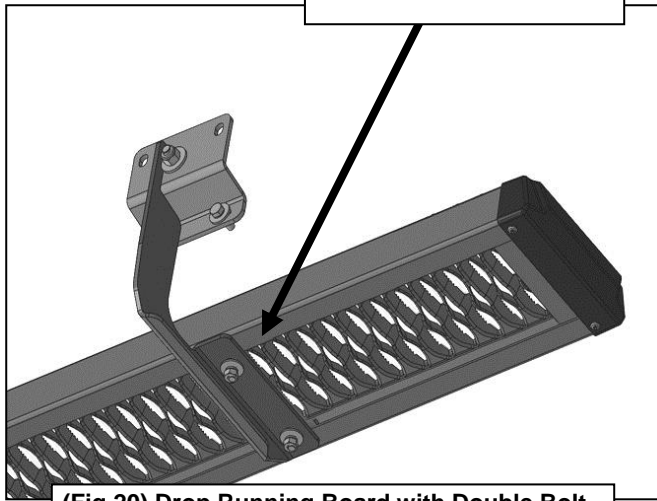

(2) 8mm Flat Washers
(2) 8mm Lock Washers
(2) 8mm Hex Nuts

(Fig 20) Drop Running Board with Double Bolt Plates down through Brackets

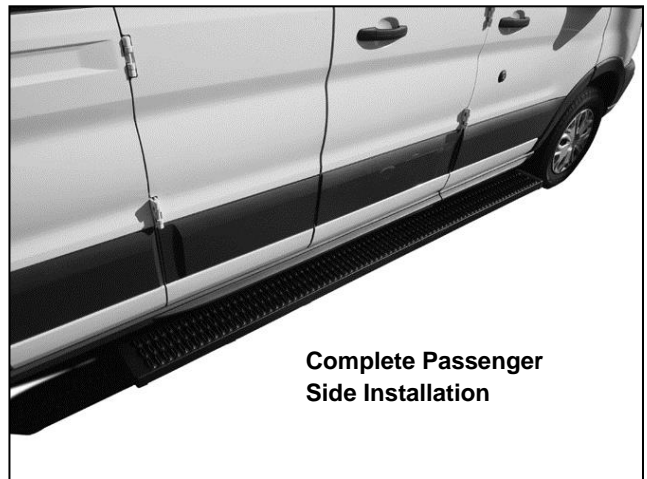

Complete Passenger Side Installation

Driver/left Side Installation Pictured

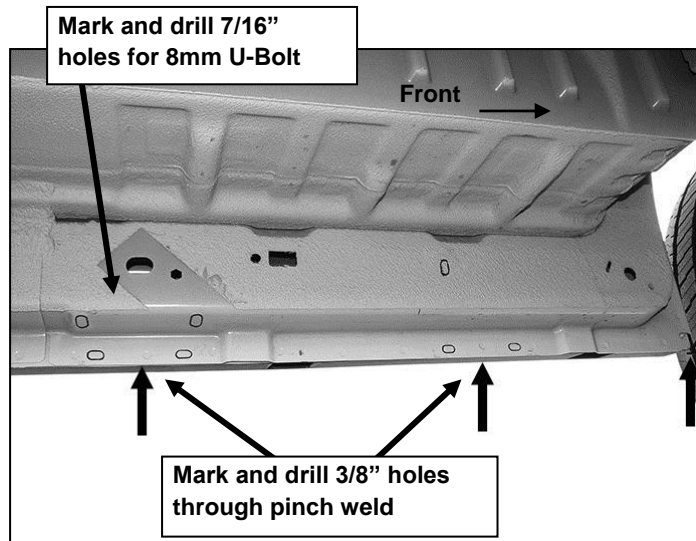

(Fig 21) Driver side front and rear mounting locations

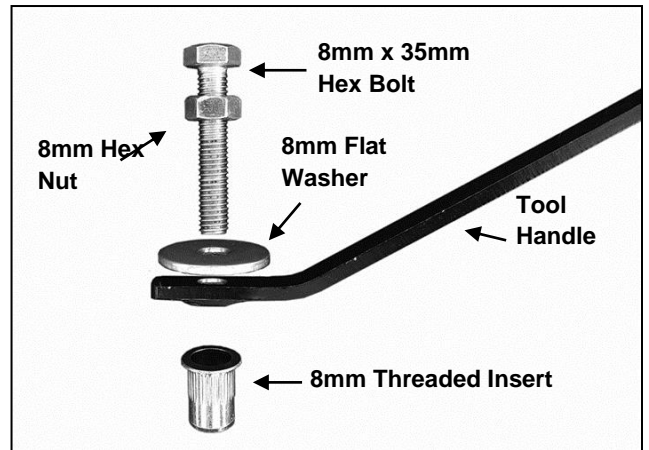

(Fig 22) Assemble 8mm Insert Tool

Hold 8mm Hex Bolt in position with wrench. Turn 8mm Hex Nut clockwise to "pull" insert



(Fig 23) Assemble 8mm Insert Tool

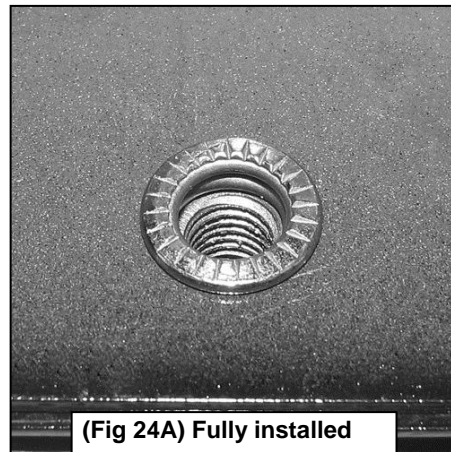

(Fig 24A) Fully installed Threaded Insert

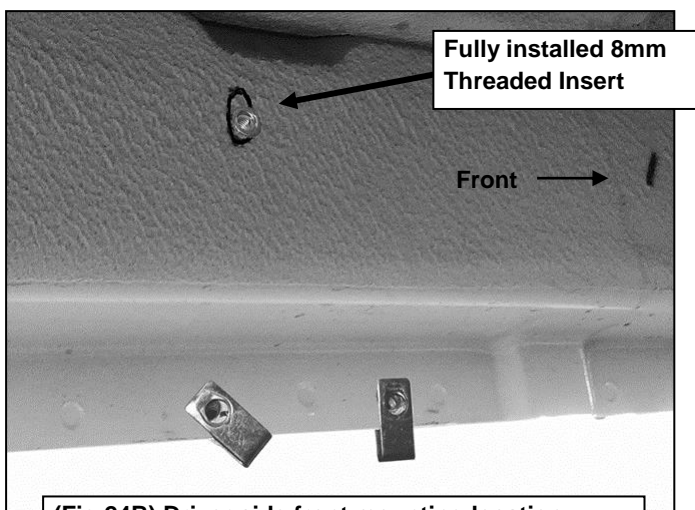

(Fig 24B) Driver side front mounting location

Driver/left Side Installation Pictured

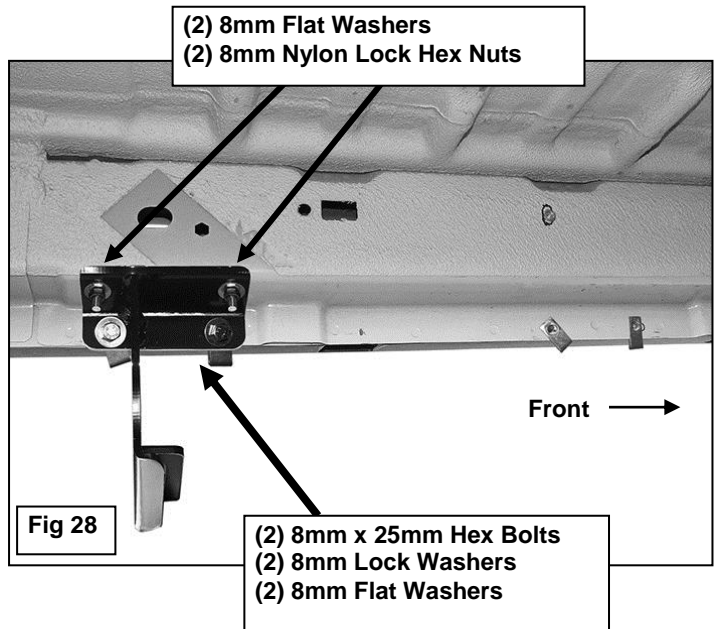
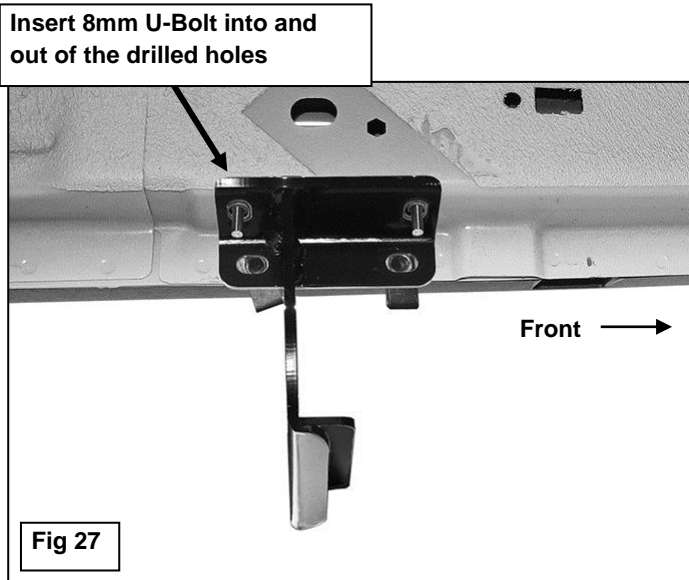
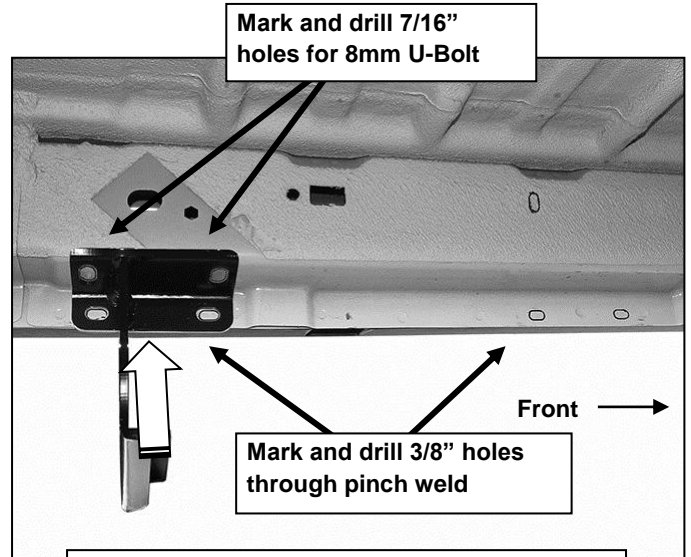
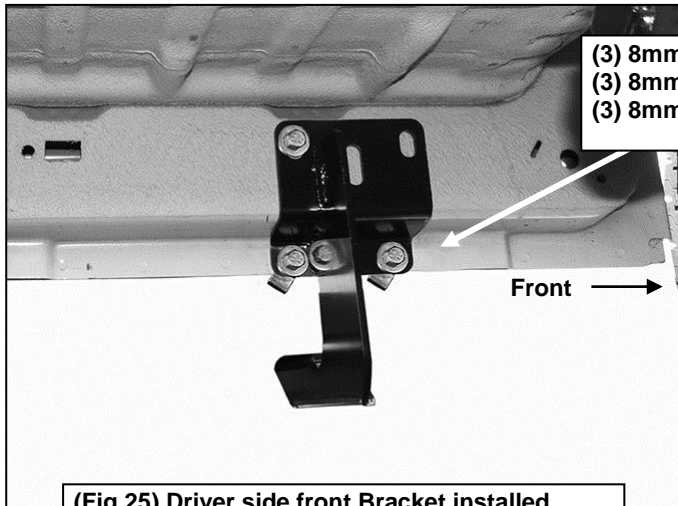

PARTS IDENTIFICATION GUIDE

Driver Side tube packed using "Green" color foam sheet. Passenger Side tube packed using "White" color foam sheet

No.	Parts Identification
1	Passenger / Right 'Rear' Bracket marked "PR"
2	Driver / Left 'Rear' Bracket marked "DR"
3	Passenger / Right 'Center' Bracket marked "PC"
4	Driver / Left 'Center' Bracket marked "DC"
5	Passenger / Right 'Front' Bracket marked "PF"
6	Driver / Left 'Front' Bracket marked "DF"

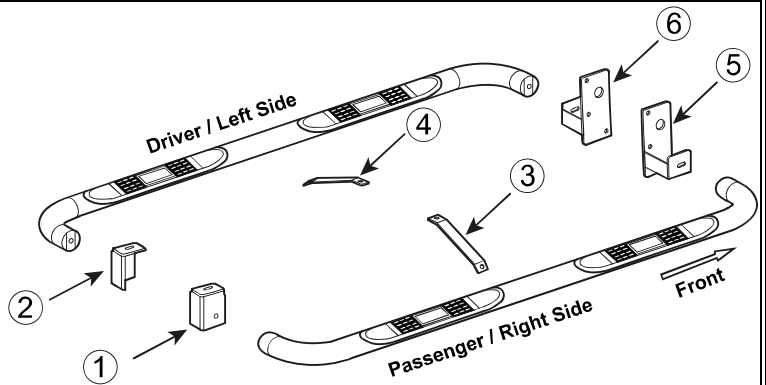

Note:

- This guide is to identify the parts and not a reference for part count.
- For part count, refer Parts List.
- Product / Bracket image is representative and actual design may vary.

PRODUCT CARE

- Periodically check the product to ensure all fasteners are tight and components are intact.
- Regular waxing is recommended to protect the finish of the product.
- **Use ONLY Non-Abrasive automotive wax.** Use of any soap, polish or wax that contains an abrasive is detrimental and can scratch the finish leading to corrosion.
- Aluminum polish may be used to polish small scratches and scuffs for **Stainless Steel finish.**
- Mild soap may be used to clean the product for both **Stainless Steel and Black finish.**

FAQ's

1. Hardware's are not of correct size.

In GMC / Chevrolet truck model 2006 & up, customer needs to reuse the factory body bolts to install the bracket. If your vehicle is not GMC / Chevrolet 2006 & up, ensure that holes are not partially covered with any plastic grommet or rust? If it is, remove the plastic grommet & rust from the thread holes & re-try the installation.

2. Mounting Bracket are not getting Installed properly.

In some cases Illustration images shown in Installation manual may not be the exactly same as per actual vehicle images ,also if Driver / Passenger side mounting brackets are very identical in the design, suggest referring Parts Identification guide to avoid fitment issue.

3. Products are thumping / rattling after installation.

Ensure that all required mounting brackets / hardware's are installed & tighten correctly. Suggest using white lithium / regular grease between the metal to metal contact surfaces.

4. Side Bar is not aligning with vehicle / Step Pads are not aligning with vehicle doors.

Side bar may be interchanged or mounting brackets are not installed at the correct position in the vehicle. Refer Parts identification guide.

5. Missing / Excess Hardware.

Recheck hardware count as per the part list.

6. Product not installing properly.

Ensure make model year, cab length and bed size of your vehicle is listed in the application. All installation steps are followed correctly.

Check out these other TrailFX Products!!

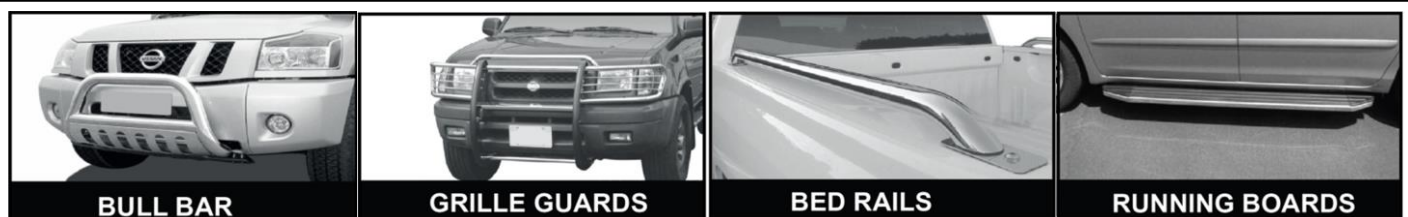

BULL BAR

GRILLE GUARDS

BED RAILS

RUNNING BOARDS

Keystone Automotive Operations Inc. (KAO) warrants this product to be free of defects in material and workmanship at the time of purchase by the original retail consumer. KAO disclaims any other warranties, express or implied, including the warranty of fitness for a particular purpose or an intended use. If the product is found to be defective, KAO may replace or repair the product at our option, when the product is returned prepaid, with proof of purchase. Alteration to, improper installation, or misuse of this product voids the warranty. KAO's liability is limited to repair or replacement of products found to be defective, and specifically excludes liability for any incidental or consequential loss or damage.