

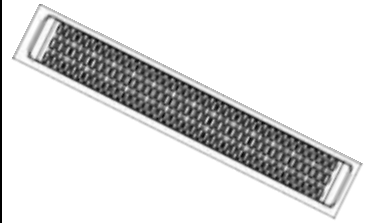

# Aggressive Rear Bumper Step

## Part No. ABSV004B



Fits: **2007 - 2009**  
**2007 - 2009**  
**2010 - Current**

**Freightliner Sprinter Van**  
**Dodge Sprinter Van**  
**Mercedes-Benz Sprinter Van**



EXCL. MODELS WITH RECEIVER HITCH, MAY IMPACT THE FUNCTION OF BACKUP SENSORS IF EQUIPPED.



60-180 min

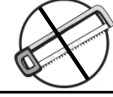

Cutting Not Required



Drilling Not Required



REMOVE CONTENTS FROM BOX. VERIFY ALL PARTS ARE PRESENT.



READ INSTRUCTIONS CAREFULLY BEFORE STARTING INSTALLATION.

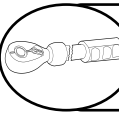

DO NOT OVER TORQUE. STANDARD OPERATING LOAD FOR TIGHTEN BODY MOUNT NUTS & BOLTS VARIES FROM 45 TO 65 FOOT POUND.

### PARTS LIST:

Qty	Part Description	Qty	Part Description
1	Aggressive Rear Step (53")	6	12mm Nylon Lock Nuts
1	Driver/left Frame Mounting Bracket	2	8mm Double Bolt Plates
1	Passenger/right Frame Mounting Bracket	4	8mm x 24mm x 2mm Flat Washers
6	12-1.75mm x 110mm Hex Bolts	4	8mm Lock Washers
12	12mm x 32mm x 3mm Flat Washers	4	8mm Hex Nuts

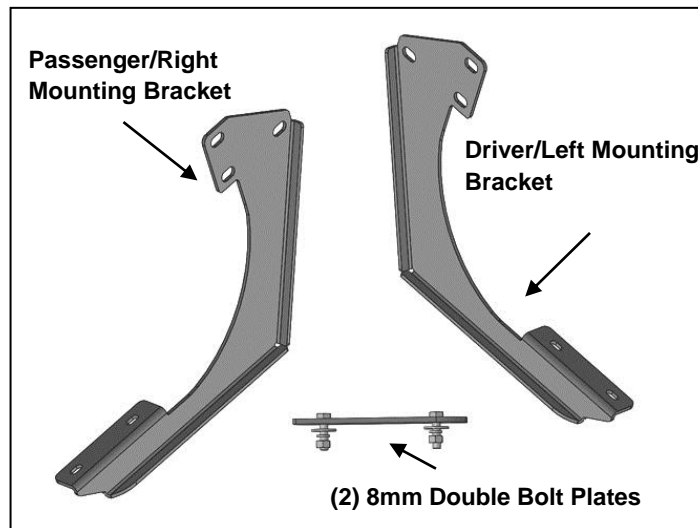

## INSTALLATION PROCEDURE:

**ASSISTANCE IS RECOMMENDED. LET EXHAUST COOL COMPLETELY BEFORE INSTALLATION.**

1. Start the installation under the driver side, rear of the vehicle, **(Figure 1)**. Locate the (4) factory holes in the end of the driver side frame channel, **(Figure 1)**. Select the driver side Mounting Bracket, **(Figure 2)**. Attach the Mounting Bracket to the outside of the frame with the included (3) 12mm x 110mm Hex Bolts, (6) 12mm Flat Washers and (3) 12mm Nylon Lock nuts. Do not fully tighten hardware, **(Figure 2)**.

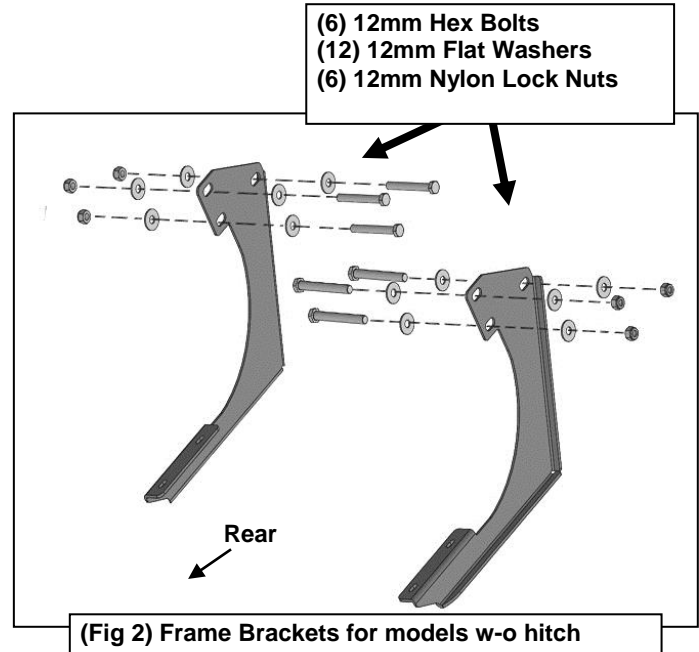
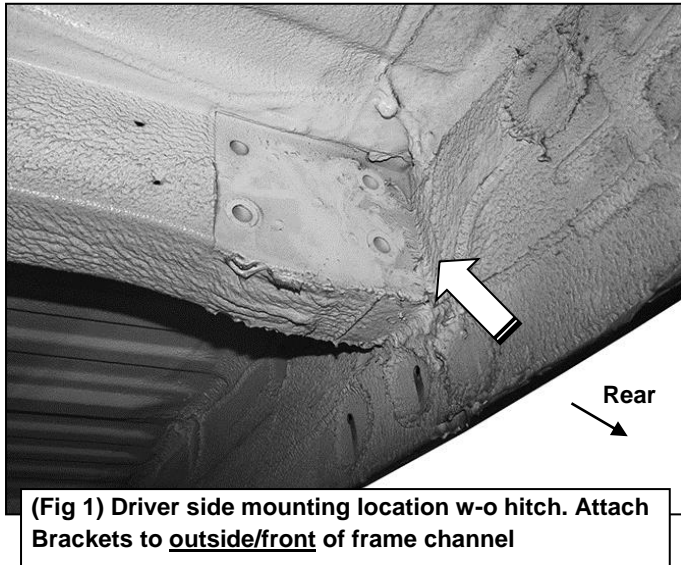

2. Locate the passenger side Mounting Location, **(Figure 3)**. Repeat the above Step to install the passenger side Mounting Bracket.

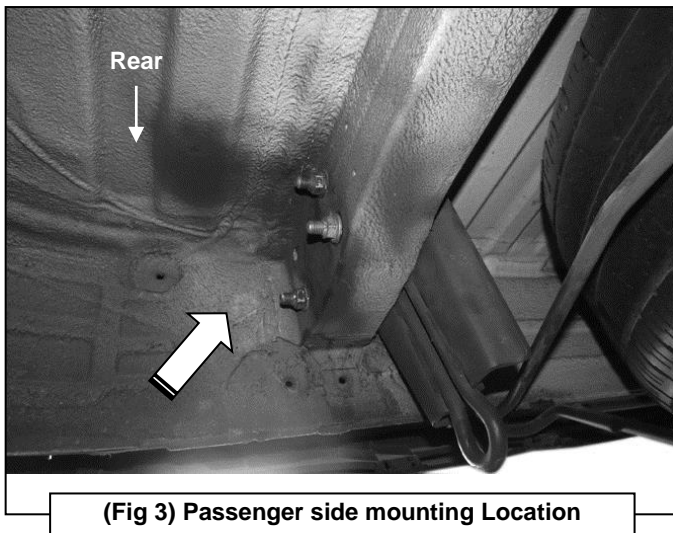

3. Carefully unwrap the Rear Step. Select the (2) 8mm Double Bolt Plates. Hold the Rear Step up to the (2) previously installed Brackets to determine correct location for Bolt Plates. Slide the (2) Double Bolt Plates into the track in the bottom of the Rear Step, **(Figure 4)**. Attach the Rear Step with Bolt Plates to the top of the (2) Brackets with (4) 8mm Flat Washers, (4) 8mm Lock Washers and (4) 8mm Hex Nuts, **(Figure 5)**. Leave loose at this time.

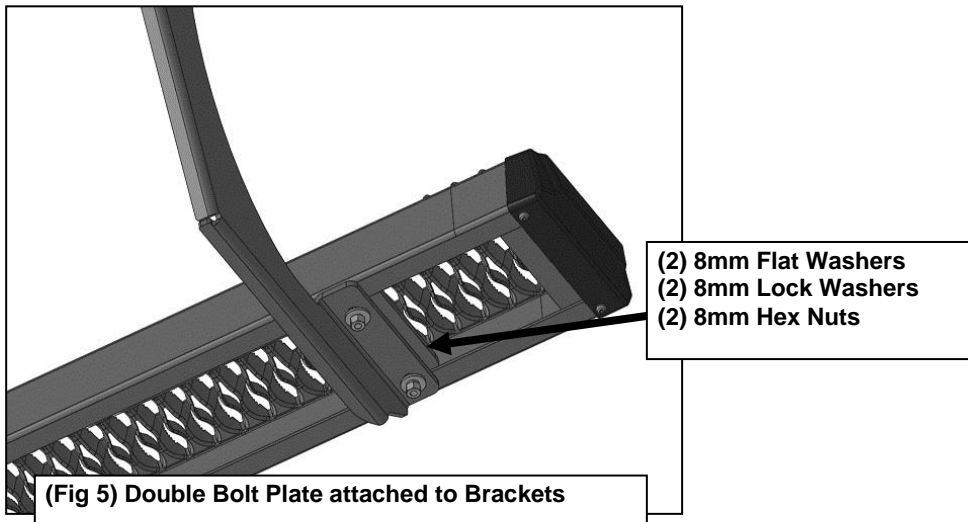
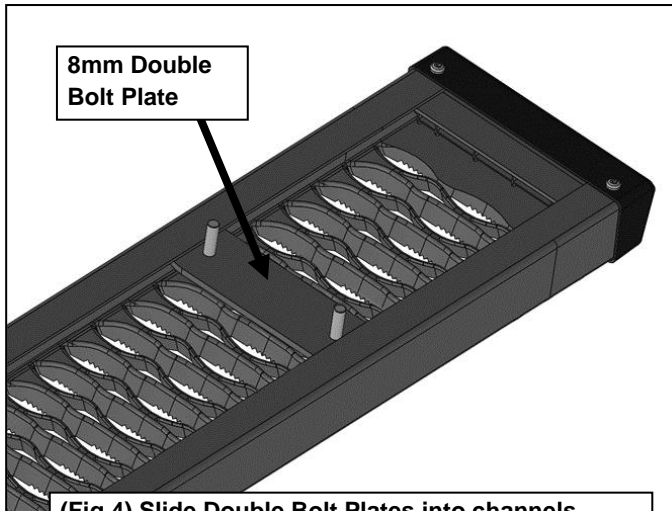

4. Adjust the Rear Step as desired and tighten all hardware.
5. Do periodic inspections to the installation to make sure that all hardware is secure and tight.

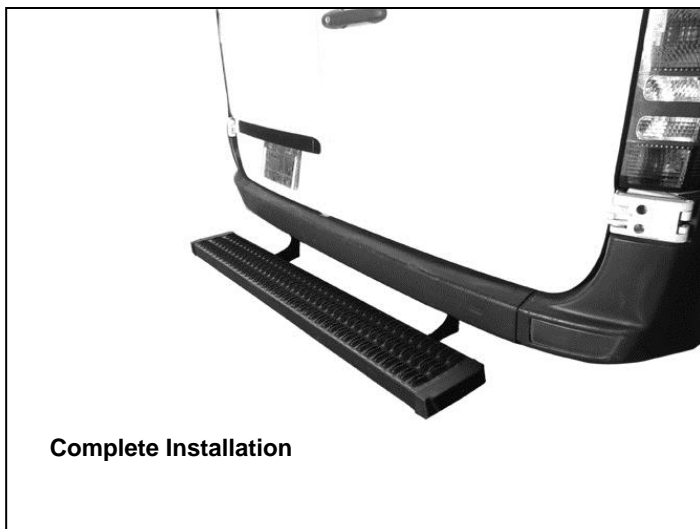

## PRODUCT CARE

- Periodically check the product to ensure all fasteners are tight and components are intact.
- Regular waxing is recommended to protect the finish of the product.
- **Use ONLY Non-Abrasive automotive wax.** Use of any soap, polish or wax that contains an abrasive is detrimental and can scratch the finish leading to corrosion.
- Aluminum polish may be used to polish small scratches and scuffs for **Stainless Steel finish.**
- Mild soap may be used to clean the product for both **Stainless Steel and Black finish.**

## FAQ's

**1. Hardware's are not of correct size.**

*In GMC / Chevrolet truck model 2006 & up, customer needs to reuse the factory body bolts to install the bracket. If your vehicle is not GMC / Chevrolet 2006 & up, ensure that holes are not partially covered with any plastic grommet or rust? If it is, remove the plastic grommet & rust from the thread holes & re-try the installation.*

**2. Mounting Bracket are not getting Installed properly.**

*In some cases Illustration images shown in Installation manual may not be the exactly same as per actual vehicle images ,also if Driver / Passenger side mounting brackets are very identical in the design, suggest referring Parts Identification guide to avoid fitment issue.*

**3. Products are thumping / rattling after installation.**

*Ensure that all required mounting brackets / hardware's are installed & tighten correctly. Suggest using white lithium / regular grease between the metal to metal contact surfaces.*

**4. Side Bar is not aligning with vehicle / Step Pads are not aligning with vehicle doors.**

*Side bar may be interchanged or mounting brackets are not installed at the correct position in the vehicle. Refer Parts identification guide.*

**5. Missing / Excess Hardware.**

*Recheck hardware count as per the part list.*

**6. Product not installing properly.**

*Ensure make model year, cab length and bed size of your vehicle is listed in the application. All installation steps are followed correctly.*

## Check out these other TrailFX Products!!



Keystone Automotive Operations Inc. (KAO) warrants this product to be free of defects in material and workmanship at the time of purchase by the original retail consumer. KAO disclaims any other warranties, express or implied, including the warranty of fitness for a particular purpose or an intended use. If the product is found to be defective, KAO may replace or repair the product at our option, when the product is returned prepaid, with proof of purchase. Alteration to, improper installation, or misuse of this product voids the warranty. KAO's liability is limited to repair or replacement of products found to be defective, and specifically excludes liability for any incidental or consequential loss or damage.