

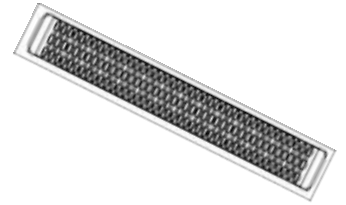

Aggressive Rear Bumper Step

Part No. ABSV001B



Fits: 2015 - Current

Ford Transit



REMOVE CONTENTS FROM BOX. VERIFY ALL PARTS ARE PRESENT.



READ INSTRUCTIONS CAREFULLY BEFORE STARTING INSTALLATION.

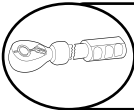

DO NOT OVER TORQUE. STANDARD OPERATING LOAD FOR TIGHTEN BODY MOUNT NUTS & BOLTS VARIES FROM 45 TO 65 FOOT POUND.



60-180 min

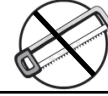

Cutting Not Required



Drilling Not Required

PARTS LIST:

Qty	Part Description	Qty	Part Description
1	Aggressive Rear Step (53")	2	10mm Plastic Retainer
1	Driver/Left Rear Mounting Bracket	2	10mm x 30mm x 2mm Flat Washers
1	Passenger/Right Rear Mounting Bracket	2	10mm Lock Washers
2	12-1.75mm x 22mm Bolt Plates	2	10mm Hex Nuts
2	12mm Plastic Retainer	2	8mm Double Bolt Plates
2	12mm x 32mm x 3mm Flat Washers	4	8mm x 24mm x 2mm Flat Washers
2	12mm Lock Washers	4	8mm Lock Washers
2	12mm Hex Nuts	4	8mm Hex Nuts
2	10-1.5mm Bolt Plates		

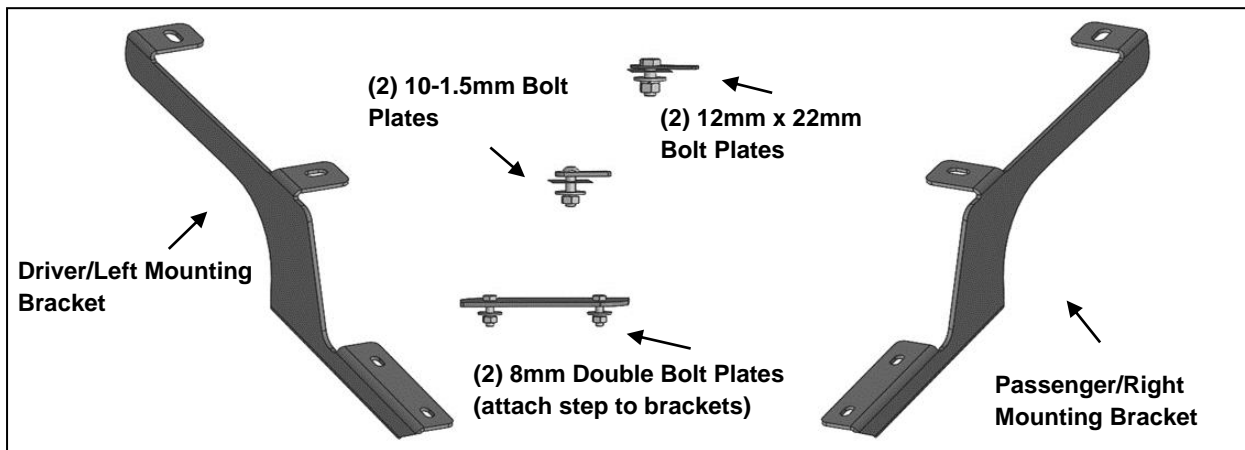

INSTALLATION PROCEDURE:

ASSISTANCE IS RECOMMENDED. LET EXHAUST COOL COMPLETELY BEFORE INSTALLATION.

1. Start the installation under the Passenger/right side, rear of the vehicle, **(Figure 1)**. Select (1) 12mm Bolt Plate and (1) 12mm Plastic Retainer, **(Figure 2)**. Insert the Bolt Plate into the forward open end of the rear frame channel and out the first hole in the bottom of the channel, **(Figures 3 & 7)**. Thread the Retainer onto the Bolt Plate to help hold it in place.
2. Next, locate the oval hole in the rearward end of the frame channel closest to the rear bumper, **(Figure 4)**. Select (1) 10mm Bolt Plate and (1) 10mm Plastic Retainer, **(Figure 5)**. Insert the Bolt Plate into the oval hole toward the front then thread the Retainer onto it to hold it in place, **(Figures 6 & 7)**.
3. Select (1) Passenger/right Side Bracket. Attach the Bracket to the forward 12mm Bolt Plate with (1) 12mm Flat Washer, (1) 12mm Lock Washer and (1) 12mm Hex Nut. Attach the Bracket to the 10mm Bolt Plate with (1) 10mm Flat Washer, (1) 10mm Lock washer and (1) 10mm Hex Nut. **VERY IMPORTANT:** With the Bolt Plate hardware loose, pull the Bracket toward the rear, then fully tighten hardware.
4. Repeat **Steps 1—3** to install the driver side Bracket.
5. Carefully unwrap the Rear Step. Select (2) 8mm Double Bolt Plates. Hold the Rear Step up to the (2) previously installed Brackets to determine correct location for Bolt Plates. Slide the (2) Double Bolt Plates into the track in the bottom of the Rear Step, **(Figure 9)**. Attach the Rear Step with Bolt Plates to the top of the (2) Brackets with (4) 8mm Flat Washers, (4) 8mm Lock Washers and (4) 8mm Hex Nuts, **(Figure 10)**. Leave loose at this time.
6. Adjust the Rear Step as desired and tighten all hardware.
7. Do periodic inspections to the installation to make sure that all hardware is secure and tight.

Passenger/right Side Installation Pictured

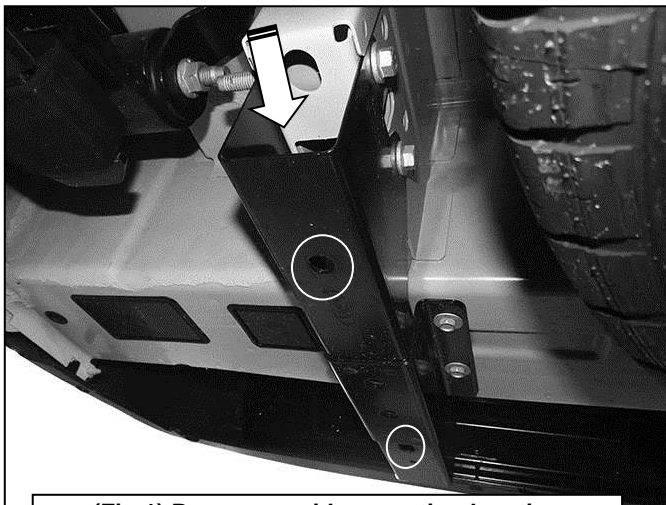

(Fig 1) Passenger side mounting location

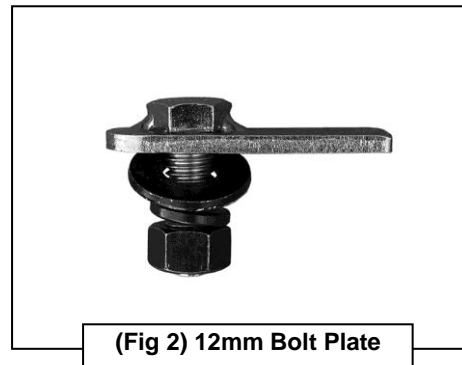

(Fig 2) 12mm Bolt Plate

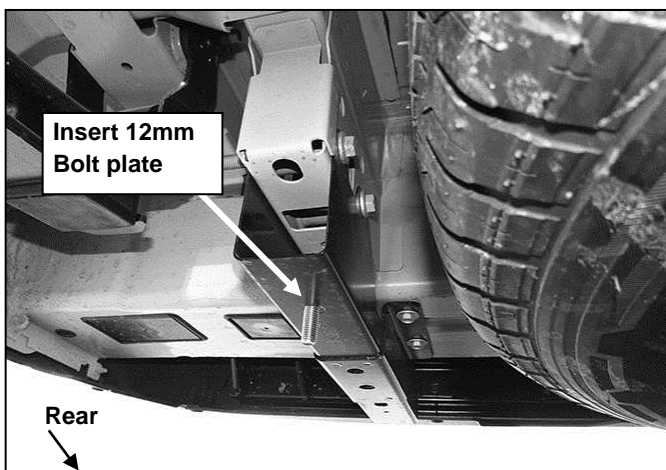

(Fig 3) Passenger side front mounting location

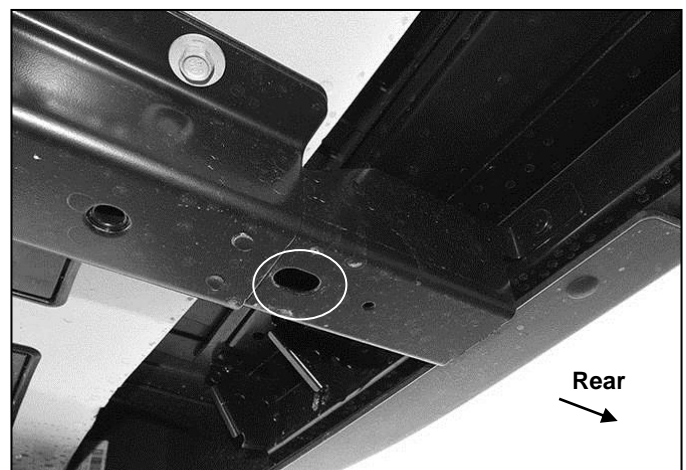

(Fig 4) Passenger side rear mounting location



(Fig 5) 10mm Bolt Plate

- (1) 12mm Bolt Plate
- (1) 12mm Plastic Retainer

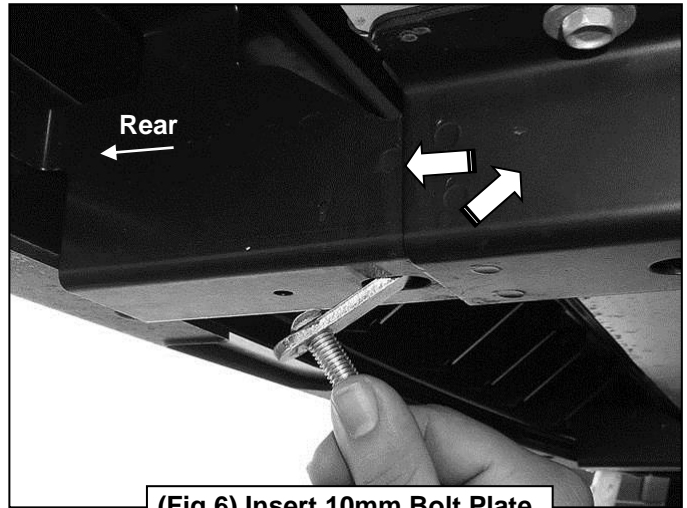

(Fig 6) Insert 10mm Bolt Plate

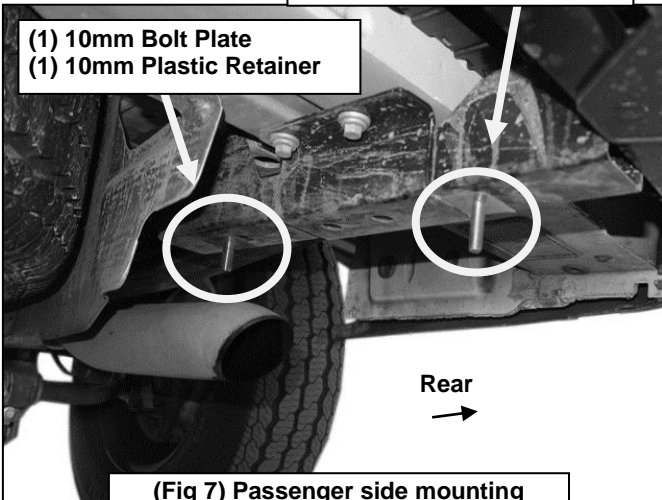

- (1) 10mm Bolt Plate
- (1) 10mm Plastic Retainer

(Fig 7) Passenger side mounting location with Bolt Plates installed

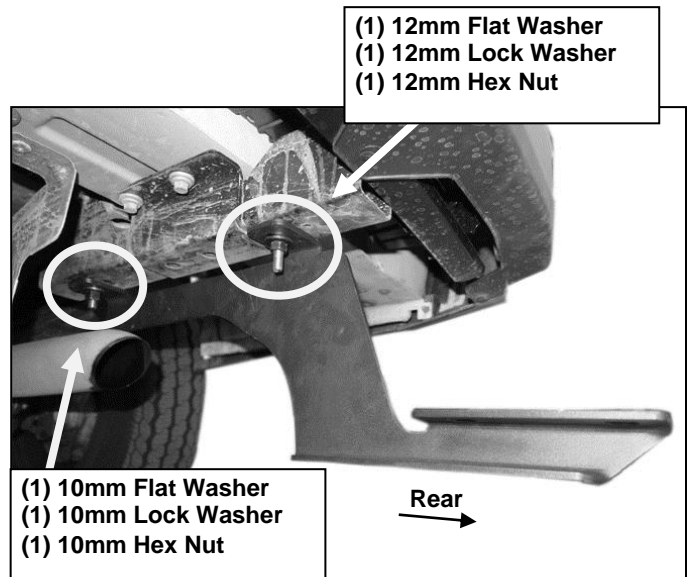

- (1) 12mm Flat Washer
- (1) 12mm Lock Washer
- (1) 12mm Hex Nut

- (1) 10mm Flat Washer
- (1) 10mm Lock Washer
- (1) 10mm Hex Nut

(Fig 8) Passenger side Mounting Bracket installed

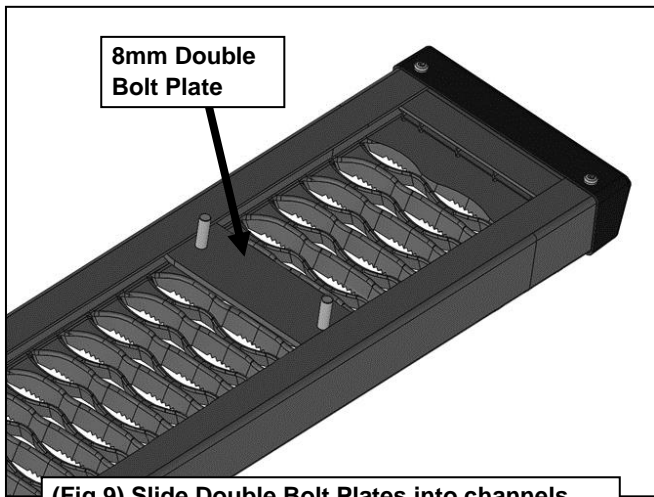

- 8mm Double Bolt Plate

(Fig 9) Slide Double Bolt Plates into channels

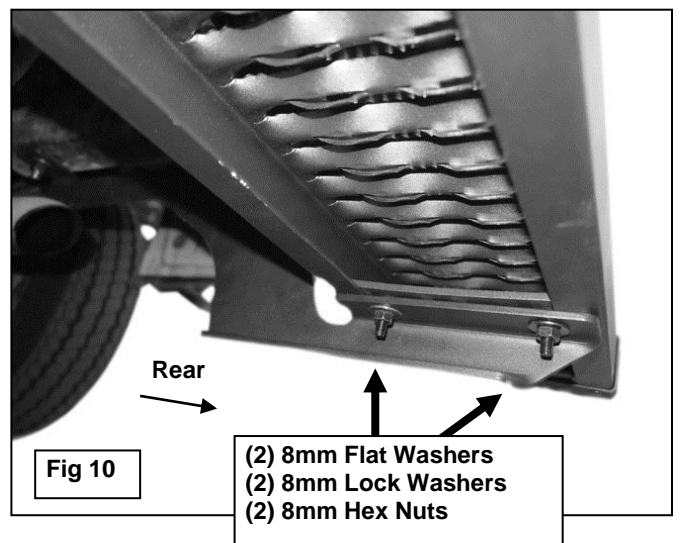

Fig 10

- (2) 8mm Flat Washers
- (2) 8mm Lock Washers
- (2) 8mm Hex Nuts



Complete Installation

PARTS IDENTIFICATION GUIDE

Driver Side tube packed using "Green" color foam sheet. Passenger Side tube packed using "White" color foam sheet

No.	Parts Identification
1	Passenger / Right 'Rear' Bracket marked "PR"
2	Driver / Left 'Rear' Bracket marked "DR"
3	Passenger / Right 'Center' Bracket marked "PC"
4	Driver / Left 'Center' Bracket marked "DC"
5	Passenger / Right 'Front' Bracket marked "PF"
6	Driver / Left 'Front' Bracket marked "DF"

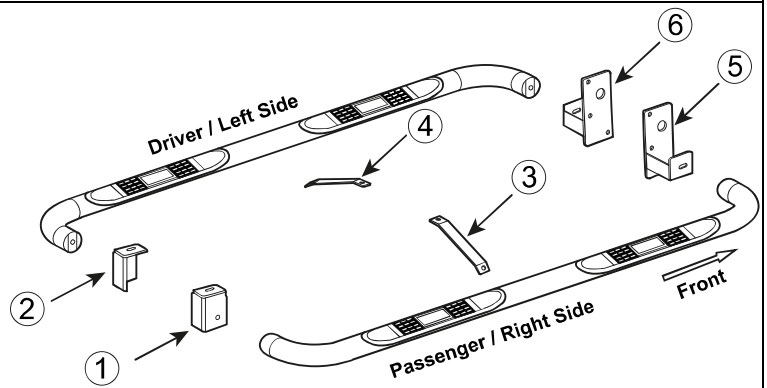

Note:

- This guide is to identify the parts and not a reference for part count.
- For part count, refer Parts List.
- Product / Bracket image is representative and actual design may vary.

PRODUCT CARE

- Periodically check the product to ensure all fasteners are tight and components are intact.
- Regular waxing is recommended to protect the finish of the product.
- **Use ONLY Non-Abrasive automotive wax.** Use of any soap, polish or wax that contains an abrasive is detrimental and can scratch the finish leading to corrosion.
- Aluminum polish may be used to polish small scratches and scuffs for **Stainless Steel finish.**
- Mild soap may be used to clean the product for both **Stainless Steel and Black finish.**

FAQ's

1. Hardware's are not of correct size.

In GMC / Chevrolet truck model 2006 & up, customer needs to reuse the factory body bolts to install the bracket. If your vehicle is not GMC / Chevrolet 2006 & up, ensure that holes are not partially covered with any plastic grommet or rust? If it is, remove the plastic grommet & rust from the thread holes & re-try the installation.

2. Mounting Bracket are not getting Installed properly.

In some cases Illustration images shown in Installation manual may not be the exactly same as per actual vehicle images ,also if Driver / Passenger side mounting brackets are very identical in the design, suggest referring Parts Identification guide to avoid fitment issue.

3. Products are thumping / rattling after installation.

Ensure that all required mounting brackets / hardware's are installed & tighten correctly. Suggest using white lithium / regular grease between the metal to metal contact surfaces.

4. Side Bar is not aligning with vehicle / Step Pads are not aligning with vehicle doors.

Side bar may be interchanged or mounting brackets are not installed at the correct position in the vehicle. Refer Parts identification guide.

5. Missing / Excess Hardware.

Recheck hardware count as per the part list.

6. Product not installing properly.

Ensure make model year, cab length and bed size of your vehicle is listed in the application. All installation steps are followed correctly.

Check out these other TrailFX Products!!



Keystone Automotive Operations Inc. (KAO) warrants this product to be free of defects in material and workmanship at the time of purchase by the original retail consumer. KAO disclaims any other warranties, express or implied, including the warranty of fitness for a particular purpose or an intended use. If the product is found to be defective, KAO may replace or repair the product at our option, when the product is returned prepaid, with proof of purchase. Alteration to, improper installation, or misuse of this product voids the warranty. KAO's liability is limited to repair or replacement of products found to be defective, and specifically excludes liability for any incidental or consequential loss or damage.