

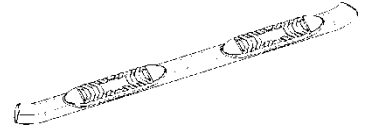

5" Oval WTW Sidebar

Part No. A7083S /B



Dodge Ram 1500 Crew Cab

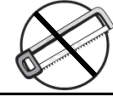

60-180 min

Cutting Not Required

Drilling Is Required



REMOVE CONTENTS FROM BOX. VERIFY ALL PARTS ARE PRESENT.



READ INSTRUCTIONS CAREFULLY BEFORE STARTING INSTALLATION.

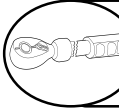

DO NOT OVER TORQUE. STANDARD OPERATING LOAD FOR TIGHTEN BODY MOUNT NUTS & BOLTS VARIES FROM 45 TO 65 FOOT POUND.

PARTS LIST:

Qty	Part Description	Qty	Part Description
1	Driver/left Side 5in WTW Sidebar	2	10mm Lock Washers
1	Passenger/right Side 5in Sidebar	2	10-1.50 Hex Nuts
4	Front & Center Brackets (use left or right)	2	8-1.25mm x 30mm Hex Bolts
1	Driver/left Side Rear Bracket	12	8-1.25mm x 25mm Combo Bolts
1	Passenger/right Side Rear Bracket	16	8mm x 24mm x 2mm Flat Washers
1	Driver/left Side Rear Support Bracket	14	8-1.25mm Nylon Lock Nuts
1	Passenger/right Side Rear Support Bracket	2	6-1.00mm x 30mm Hex Bolts
2	10-1.50mm Bolt Plate	4	6mm x 18mm x 1.6mm Flat Washers
2	10mm Plastic Retainers	2	6-1.00mm Nylon Lock Nuts
2	10mm x 30mm x 2.5mm Flat Washers		

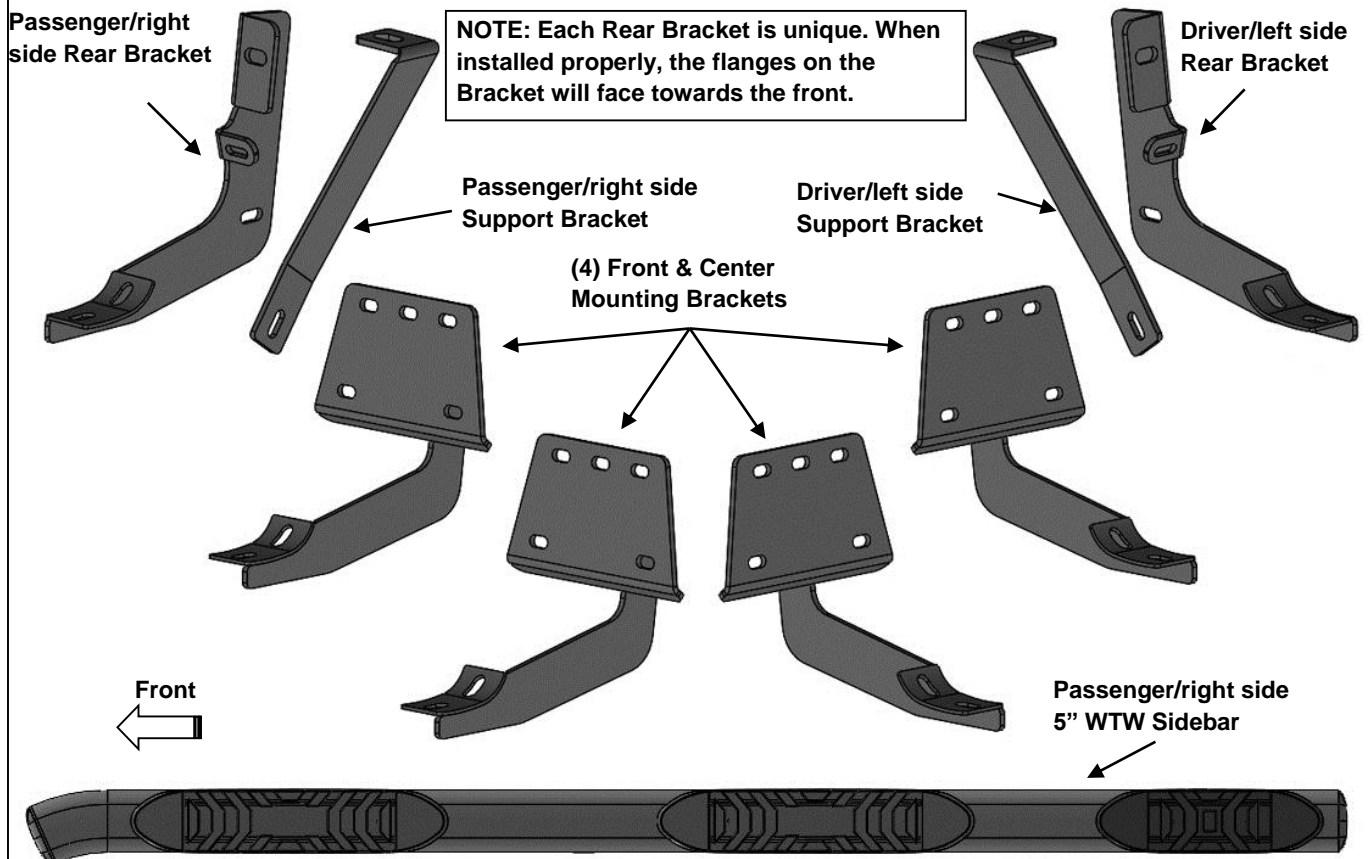

INSTALLATION PROCEDURE:

1. Start the installation under the passenger side of the vehicle. Locate the front (3) factory studs along the inner side of the body panel, **(Figure 1)**. **NOTE:** Chase threads on the studs first before installing Brackets to remove paint buildup.
2. Select (1) Front & Center Bracket. **NOTE:** There are (4) Front & Center Brackets that will fit left or right side. Attach the Mounting Bracket to the (3) factory studs with (3) 8mm Flat Washers and (3) 8mm Nylon Lock Nuts, **(Figures 2 & 3)**. Leave brackets loose at this time.
3. Move to the center mounting location, **(Figure 4)**. Repeat **Steps 1 & 2** to install (1) Front/Center Bracket in the center mounting location, **(Figure 5)**.
4. Move to the end of the cab and locate mounting slot, **(Figure 6)**. Remove the sealing tape from the mounting slot on the body panel.
5. Select (1) 10mm Bolt Plate and (1) 10mm Plastic Retainer, **(Figure 7)**. Partially thread the Plastic Retainer onto the Bolt Plate. Insert the Bolt Plate with Retainer into the rear mounting slot, **(Figure 8)**. **NOTE:** The Plastic Retainer is used to help prevent the Bolt Plate from falling inside the body panel and to aid in Bracket installation.
6. Next, select the Passenger/right side Rear Bracket, **(Figure 9)**. **NOTE:** Each Rear Bracket is unique. When installed properly, the Rear Bracket flanges will face towards the front, **(Figure 9)**. Attach the Bracket to the Bolt Plate using (1) 10mm Flat Washer, (1) 10mm Lock Washer and (1) 10mm Hex Nut, **(Figure 9)**. Do not tighten hardware.
7. Select the Passenger/right side Support Bracket. Use the illustration above and **Figure 10** to help determine the correct Bracket.
8. Remove the rear body bolt from the body mount, **(Figure 11)**. Reuse the factory bolt to attach the top end of the Support Bracket to the body mount. Attach the bottom end of the Support Bracket to the front side of the Rear Bracket with (1) 8mm Hex Bolt, (2) 8mm Flat Washers and (1) 8mm Nylon Lock Nut, **(Figure 12)**. Do not tighten hardware.
9. Carefully unwrap and select the Passenger/right Sidebar. Use the illustration above to help identify the correct Sidebar. Place the Sidebar on top of the Brackets. **IMPORTANT:** Do not slide, (front to back or rotate), the Sidebar on the Brackets or damage to the finish on the Sidebar may result.
10. Attach the Sidebar to the Brackets with (6) 8mm Combo Hex Bolts, **(Figures 13—16)**. Do not tighten hardware at this time.
11. Level the Sidebar to the vehicle. Make sure all (3) Brackets are tight against the bottom of the body panel and tighten all mounting hardware.
12. Mark drilling location onto the pinch weld, **(Figure 17)**.
13. Temporarily remove the Rear Bracket. Drill (1) 1/4" hole through the pinch weld. **IMPORTANT:** Do not drill too close to the bottom edge of the pinch weld.
14. Repeat **Steps 6 & 8** to attach Rear Bracket to Bolt Plate and Support Bracket.
15. Use (1) 6mm Hex Bolt, (2) 6mm Flat Washers and (1) 6mm Nylon Lock Nut to attach the Bracket to the pinch weld, **(Figure 18)**. **NOTE:** Insert the Bolt from outside the pinch weld and out through the Bracket.
16. Check for level then fully tighten all hardware.
17. Repeat **Steps 1—16** for Driver/left Sidebar installation.
18. Do periodic inspections to the installation to make sure that all hardware is secure and tight.

Passenger/right Side Installation Pictured

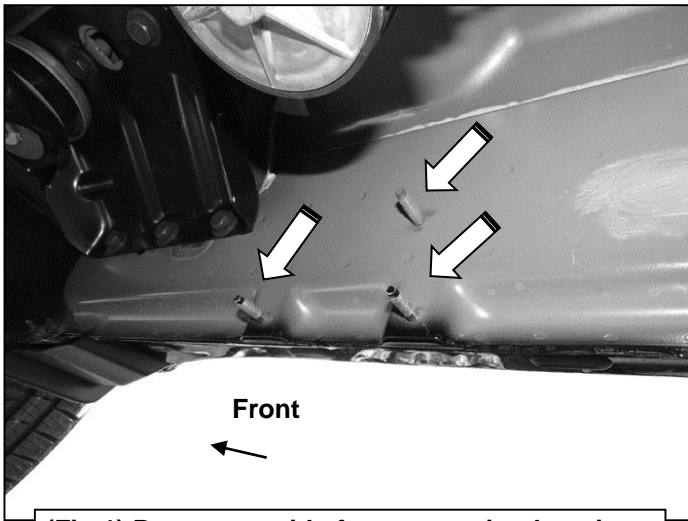

(Fig 1) Passenger side front mounting location

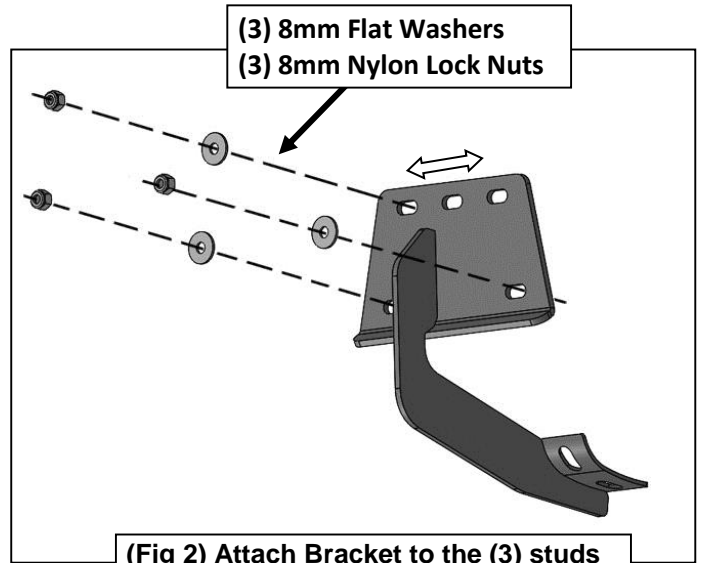

(Fig 2) Attach Bracket to the (3) studs

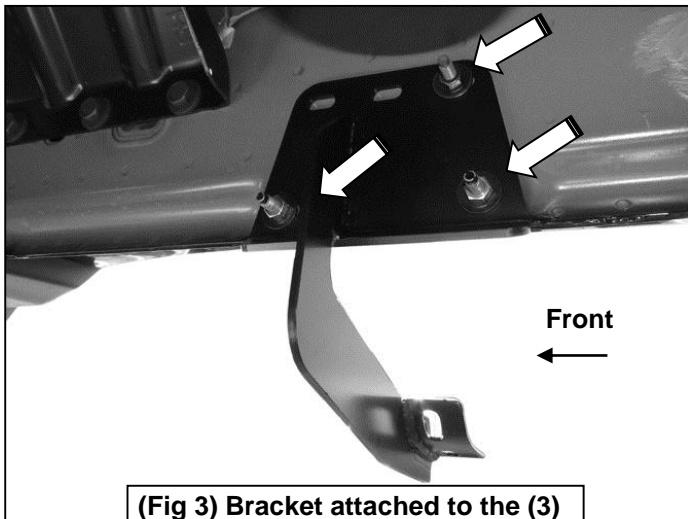

(Fig 3) Bracket attached to the (3) front studs on the passenger side

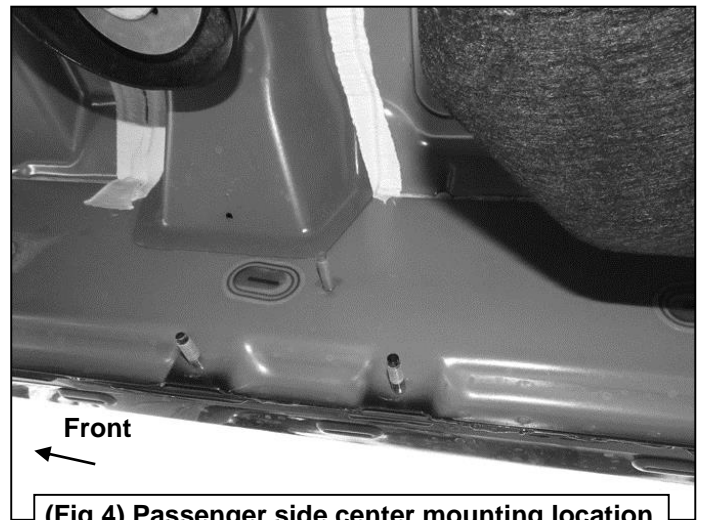

(Fig 4) Passenger side center mounting location

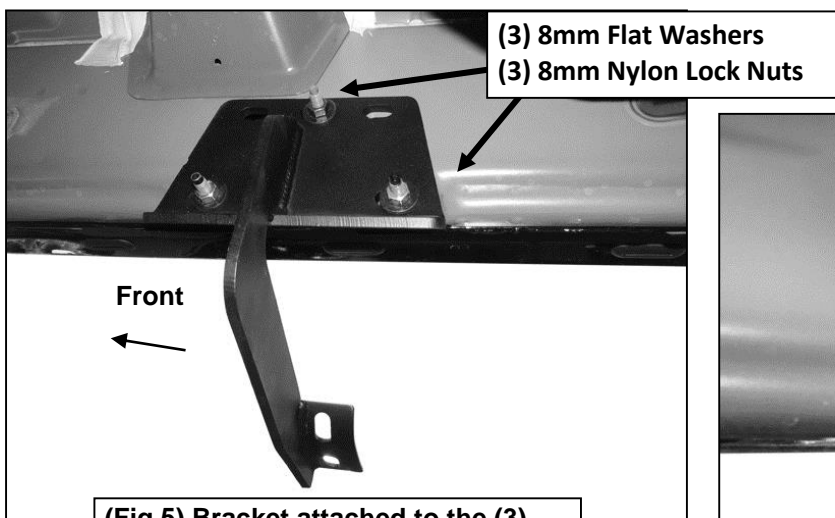

(Fig 5) Bracket attached to the (3) center studs on the passenger side

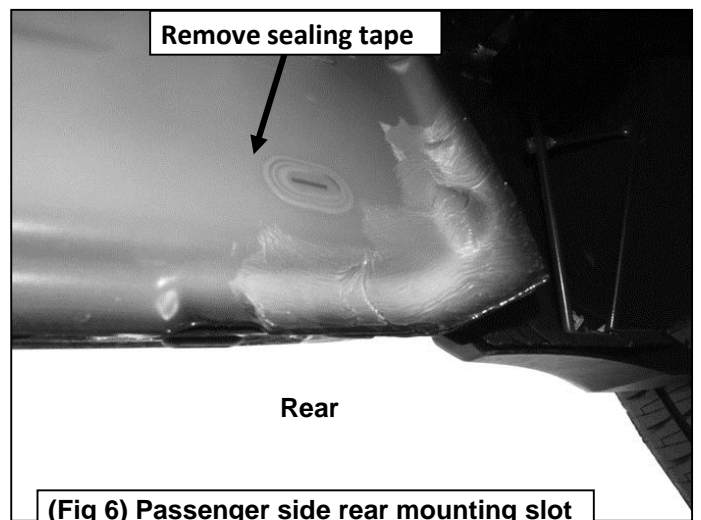

(Fig 6) Passenger side rear mounting slot

Passenger/right Side Installation Pictured

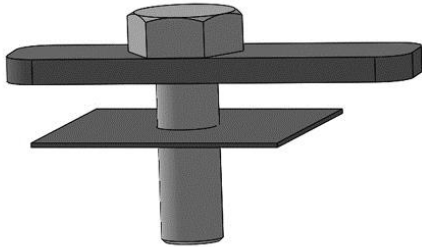

(Fig 7) 10mm Bolt Plate with Plastic Retainer

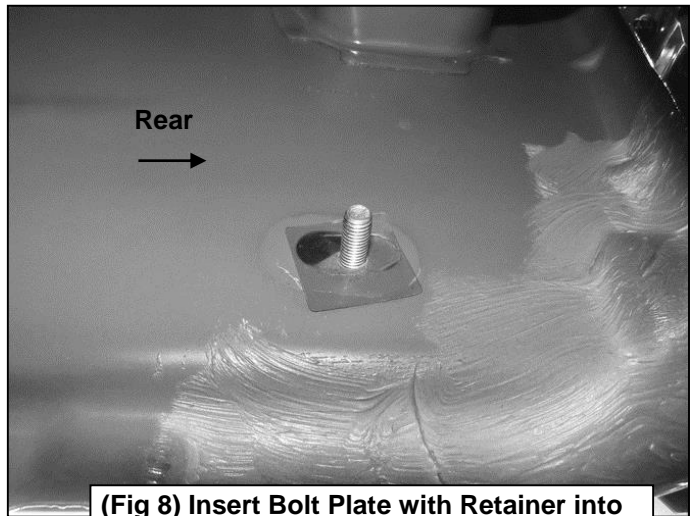

(Fig 8) Insert Bolt Plate with Retainer into the rear slot on the body panel. Plastic Retainer is used to help prevent the Bolt Plate from falling inside the body panel.

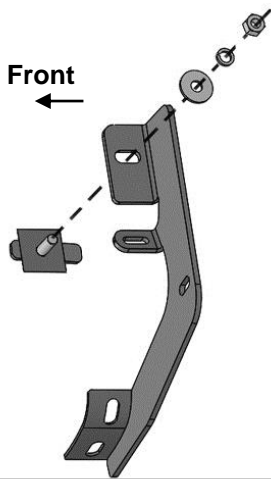

10mm Flat Washer
10mm Lock Washer
10mm Hex Nut

(Fig 9) Passenger/right side Rear Bracket

NOTE: Each Rear Bracket is unique. When installed properly, the flanges on the Bracket will face towards the front.

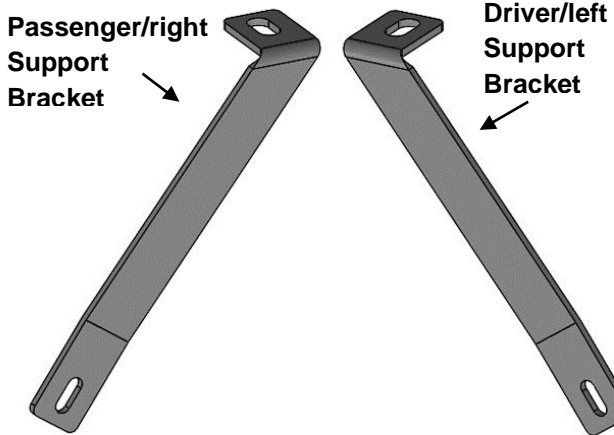

(Fig 10) Rear Support Bracket

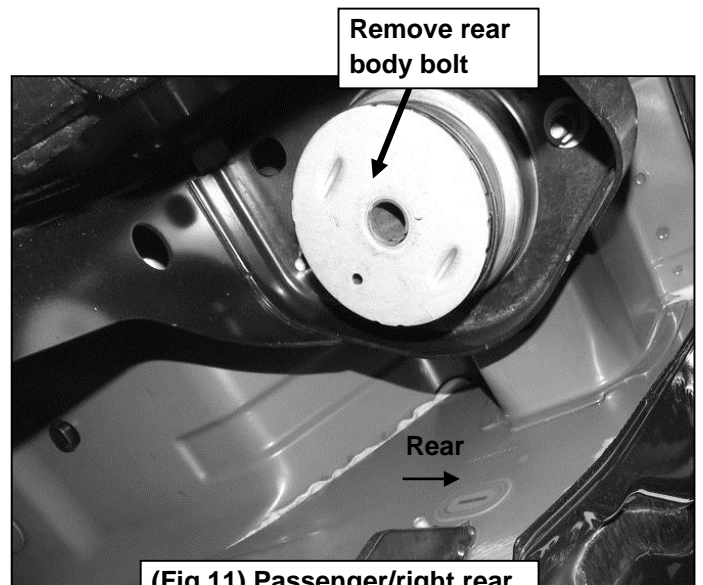

(Fig 11) Passenger/right rear body bolt mounting location

Passenger/right Side Installation Pictured

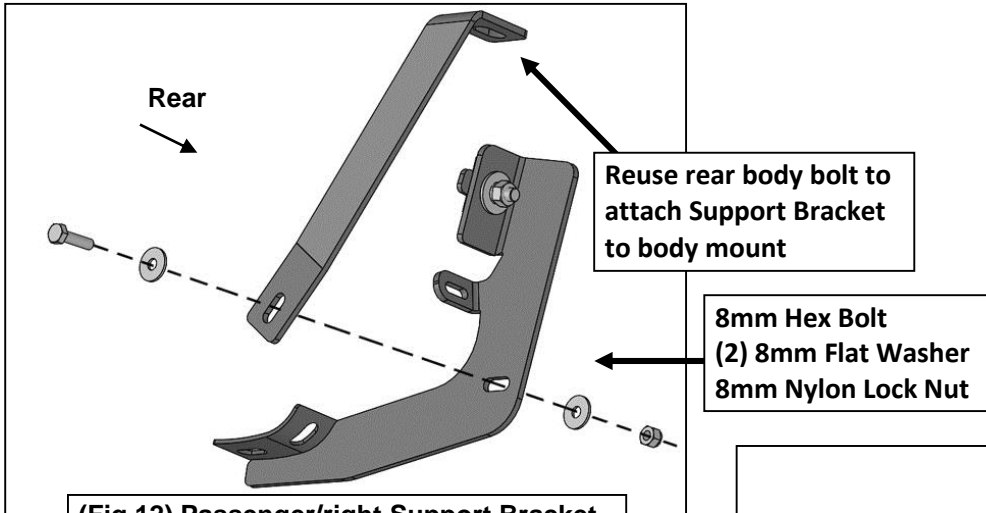

(Fig 12) Passenger/right Support Bracket attached to Rear Bracket illustrated

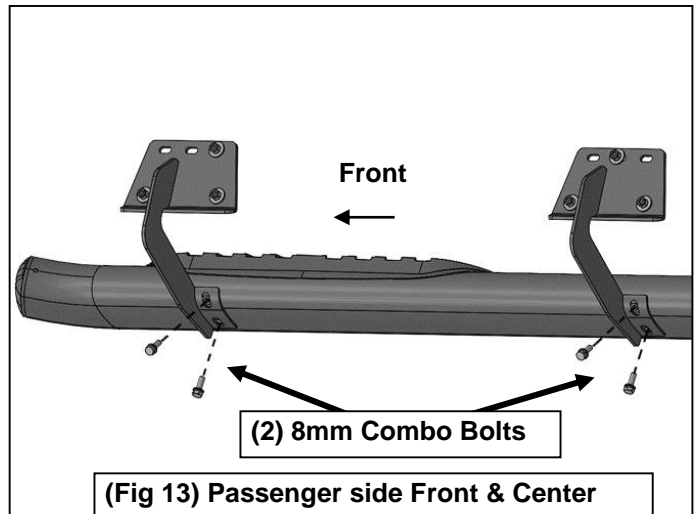

(Fig 13) Passenger side Front & Center Brackets attached to Sidebar illustrated

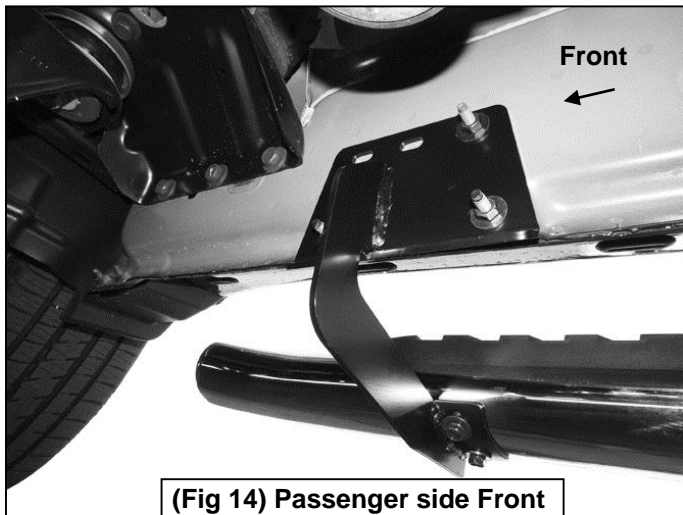

(Fig 14) Passenger side Front Bracket attached to Sidebar

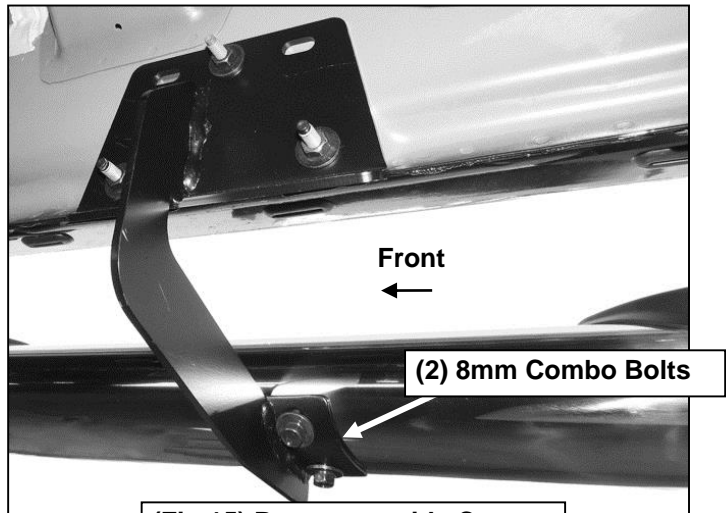

(Fig 15) Passenger side Center Bracket attached to Sidebar

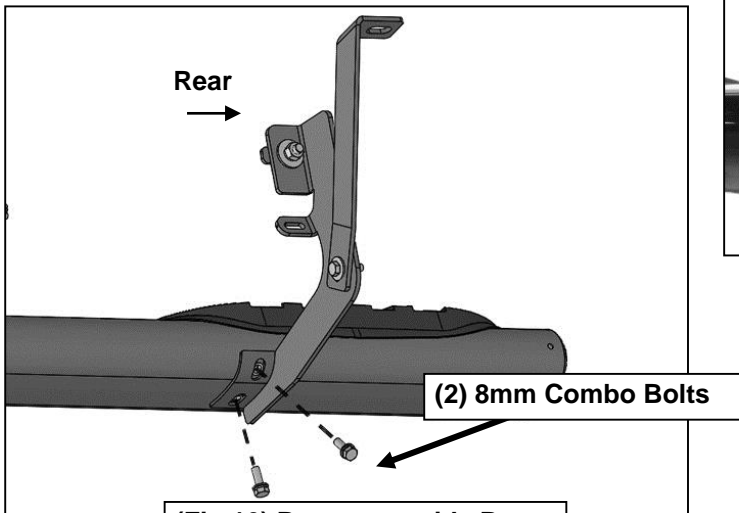

(Fig 16) Passenger side Rear Bracket attached to Sidebar

Passenger/right Side Installation Pictured

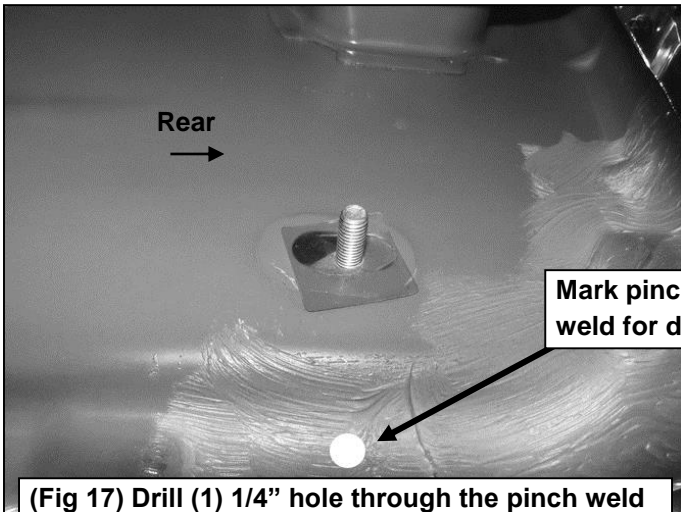

(Fig 17) Drill (1) 1/4" hole through the pinch weld to attach the Rear Bracket to the pinch weld

IMPORTANT: Drilling is required. Drill 1/4" hole through pinch weld to attach the bracket. Complete installation of Sidebar first and level Sidebar before drilling hole for bracket.

6mm Hex Bolt
(2) 6mm Flat Washers
6mm Nylon Lock Nut

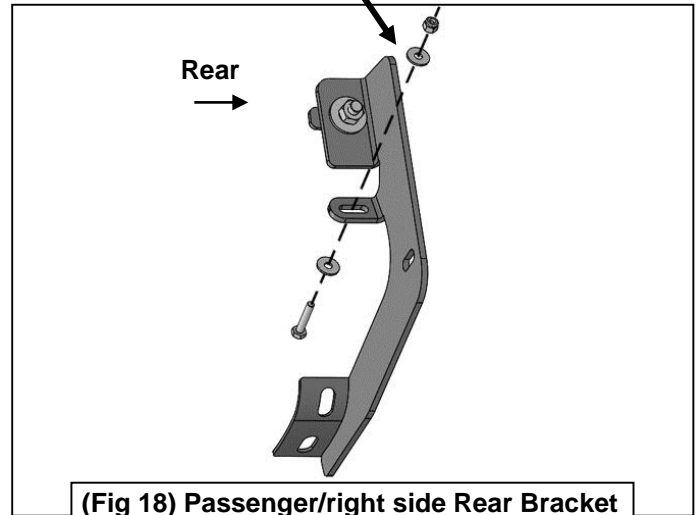

(Fig 18) Passenger/right side Rear Bracket attached to the pinch weld illustrated

No.	Parts Identification
1	Passenger / Right 'Rear' Bracket marked "PR"
2	Driver / Left 'Rear' Bracket marked "DR"
3	Passenger / Right 'Center' Bracket marked "PC"
4	Driver / Left 'Center' Bracket marked "DC"
5	Passenger / Right 'Front' Bracket marked "PF"
6	Driver / Left 'Front' Bracket marked "DF"

Note:

- This guide is to identify the parts and not a reference for part count.
- For part count, refer Parts List.
- Product / Bracket image is representative and actual design may vary.

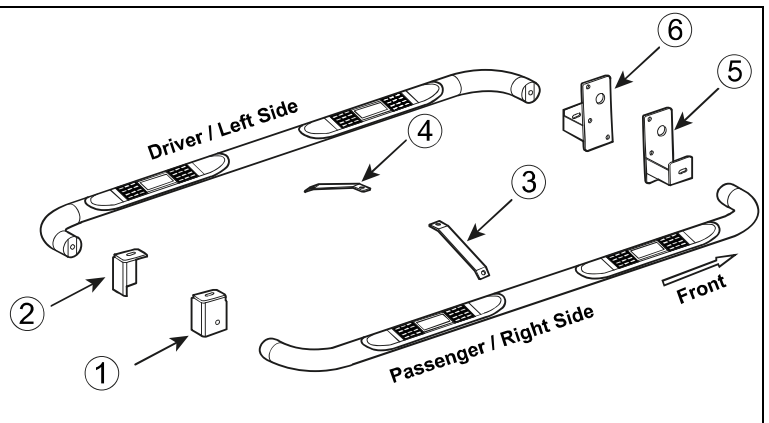

PRODUCT CARE

- Periodically check the product to ensure all fasteners are tight and components are intact.
- Regular waxing is recommended to protect the finish of the product.
- **Use ONLY Non-Abrasive automotive wax.** Use of any soap, polish or wax that contains an abrasive is detrimental and can scratch the finish leading to corrosion.
- Aluminum polish may be used to polish small scratches and scuffs for **Stainless Steel finish.**
- Mild soap may be used to clean the product for both **Stainless Steel and Black finish.**

FAQ's

1. Hardware's are not of correct size.

In GMC / Chevrolet truck model 2006 & up, customer needs to reuse the factory body bolts to install the bracket. If your vehicle is not GMC / Chevrolet 2006 & up, ensure that holes are not partially covered with any plastic grommet or rust? If it is, remove the plastic grommet & rust from the thread holes & re-try the installation.

2. Mounting Bracket are not getting Installed properly.

In some cases Illustration images shown in Installation manual may not be the exactly same as per actual vehicle images ,also if Driver / Passenger side mounting brackets are very identical in the design, suggest referring Parts Identification guide to avoid fitment issue.

3. Products are thumping / rattling after installation.

Ensure that all required mounting brackets / hardware's are installed & tighten correctly. Suggest using white lithium / regular grease between the metal to metal contact surfaces.

4. Side Bar is not aligning with vehicle / Step Pads are not aligning with vehicle doors.

Side bar may be interchanged or mounting brackets are not installed at the correct position in the vehicle. Refer Parts identification guide.

5. Missing / Excess Hardware.

Recheck hardware count as per the part list.

6. Product not installing properly.

Ensure make model year, cab length and bed size of your vehicle is listed in the application. All installation steps are followed correctly.

Check out these other TrailFX Products!!



Keystone Automotive Operations Inc. (KAO) warrants this product to be free of defects in material and workmanship at the time of purchase by the original retail consumer. KAO disclaims any other warranties, express or implied, including the warranty of fitness for a particular purpose or an intended use. If the product is found to be defective, KAO may replace or repair the product at our option, when the product is returned prepaid, with proof of purchase. Alteration to, improper installation, or misuse of this product voids the warranty. KAO's liability is limited to repair or replacement of products found to be defective, and specifically excludes liability for any incidental or consequential loss or damage.