

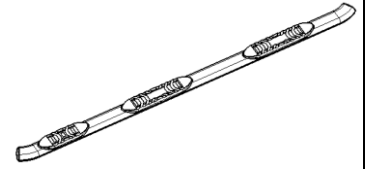

5" Oval W2W Nerf Bar

Part No. A7044S/B



Fits: 2007-2015 Chevrolet Silverado / GMC Sierra 2500/3500 Crew Cab Long Bed 8 Ft
 2007-2014 Chevrolet Silverado /GMC Sierra 1500 Crew Cab Long Bed 8 Ft

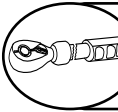

REMOVE CONTENTS FROM BOX. VERIFY ALL PARTS ARE PRESENT.

READ INSTRUCTIONS CAREFULLY BEFORE STARTING INSTALLATION.

DO NOT OVER TORQUE. STANDARD OPERATING LOAD FOR TIGHTEN BODY MOUNT NUTS & BOLTS VARIES FROM 45 TO 65 FOOT POUND.



60-180 min



Cutting Not Required



Drilling May be Required

PARTS LIST:

Qty	Part Description	Qty	Part Description
1	Driver/Left Side Bar	8	10-1.5mm x 30mm Hex Bolts
1	Passenger/Right Side Bar	12	10mm x 27mm OD x 3mm Flat Washers
5	5" Sidebar Brackets (use for left or right)	8	10mm Lock Washers
2	Bed Mounting Brackets (use for left or right)	4	10mm Hex Nuts
2	Tube Brackets (use for left or right)	4	10-1.5mm Nylon Lock Nuts
1	Passenger/right Front Upper Bracket (Incl. DEF)	13	8-1.25mm x 25mm Hex Bolt
1	Passenger/right Front Lower Bracket (Incl. DEF)	13	8mm x 24mm x 2mm Flat Washer
2	10mm Double Nut Plates	13	8mm Lock Washer
2	10mm U-Bolts	1	8mm Nylon Lock Nut (use w-bolt plate)
11	8-1.25mm Clip-On Nuts	16	8-1.25mm x 25mm Hex Bolts (Black-sidebars)
1	8mm Bolt Plate	16	8mm x 22mm OD x 2mm Flat Washers (Black-sidebars)
		16	8mm Lock Washers (Black-sidebars)

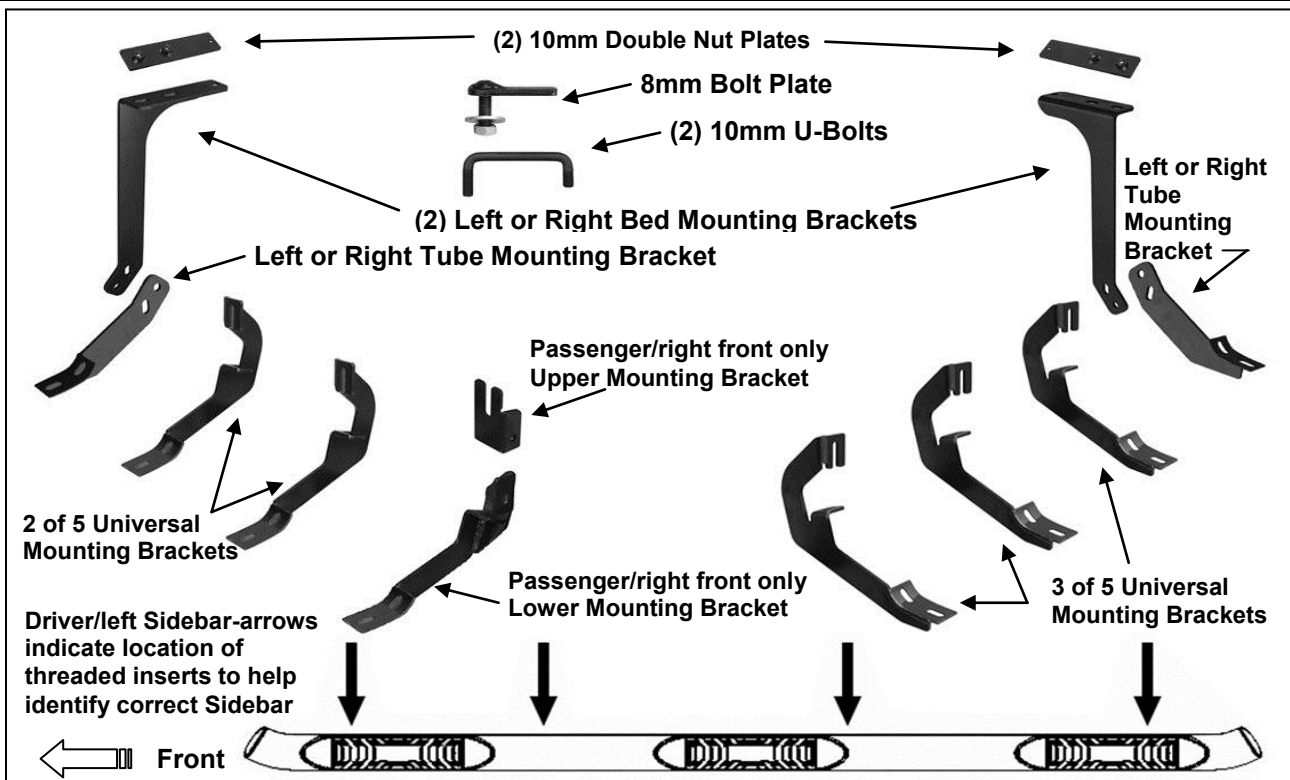

INSTALLATION PROCEDURE

1. **ASSISTANCE IS RECOMMENDED. ON MODELS WITH DEF TANK, SELECT A FLAT, LEVEL AREA FOR INSTALLATION.** Start the installation under the driver side of the vehicle. Locate the 5 tabs along the bottom edge of the body, (pinch weld). Cab Mounting Brackets will bolt to the 1st, 2nd, (just in front of center of cab), and 5th mounting tabs, **(Figure 1)**. Directly above each tab is a top mounting location on the side of the body panel. Hold a Bracket up in place to help determine the mounting holes to use along the body.

2. Determine the correct procedure for your model year and each Bracket location.

Bottom mounting location on the edge of the pinch weld.

Flat tab on pinch weld with factory installed weld nut:

Thread hex bolt into weld nut from the backside-down to clear paint from threads, **(Figure 2)**.

Flat tab on pinch weld with hole:

Select (1) 8mm Clip Nut. Slide the Clip Nut over the tab with the nut facing up behind the tab, **(Figures 3—5)**. Line up threaded nut with hole in tab. Repeat for each mounting location.

Top mounting location on the side of the body panel.

Models with factory installed threaded insert in body panel:

Thread 8mm Hex Bolt into threaded insert to clear paint as required, **(Figures 2 & 3)**.

Large and small hole in side of body panel:

Remove the rubber plug from the larger hole, **(Figure 4)**. Select (1) 8mm Clip Nut. Slide the Clip Nut into the larger hole. Line up the threaded nut with the smaller hole, **(Figure 5)**.

3. Select (1) Cab Mounting Bracket. **NOTE:** (5) Cab Brackets are universal and will fit left or right side. Bolt (1) Bracket to the Clip Nuts and/or the factory threaded holes with (2) 8mm Hex Bolts, (2) 8mm Lock Washers and (2) 8mm Flat Washers, **(Figures 6 & 7)**. Snug but do not fully tighten the hardware.
4. Repeat **Steps 1—3** to install the (2) remaining driver side Cab Brackets.
5. Move toward the bed along the side of the vehicle to just in front of the rear wheel opening. Locate the reinforcement channel welded to the bottom of the bed, **(Figures 8, 9B, 10 & 11)**. Select the appropriate installation for your year and/or model. Determine if the end of the channel is open or filled with a factory reinforcement welded into the end, **(Figures 8, 9B & 10)**.

Models with open channel, **(Figures 8 & 9B)**:

- a. Select (1) Double Nut Plate, **(Figure 9A)**. Insert the flat end of the Nut Plate into the open end of the channel. Line up the threaded hole and welded nut with the holes in the bottom of the channel, **(Figures 8 & 9B)**. **NOTE:** Nut Plate has (2) welded hex nuts to fit early, (long bed support-**Figure 8**), and late, (short bed support-**Figure 9B**), model years. Line up the welded nut with the correct hole in the outer end of the bed support.
- b. Select (1) Bed Mounting Bracket, **(Figure 13)**. Bolt the Bracket to the bottom of the channel and the Nut Plate with (2) 10mm x 30mm Hex Bolts, (2) 10mm Lock Washers and (2) 10mm Flat Washers, **(Figure 14)**. Remaining hole in the Nut Plate and Bracket will not be used. Leave hardware loose.

Models with welded-in factory reinforcement, **(Figure 10)**:

- a. Locate the blocked off hole toward the end of the channel, **(Figure 10)**. Drill a 1/2" hole through the channel, **(Figure 11)**. **IMPORTANT:** Do not drill through bottom of truck bed.
 - b. Insert the shorter end of the (1) 10mm U-Bolt into the hole closest to the frame mount and out the outer drilled hole, **(Figures 12A & 12B)**.
 - c. Select (1) Bed Mounting Bracket, **(Figure 13)**. Attach the Bracket to the bottom of the channel and U-Bolt with (2) 10mm Flat Washers, (2) 10mm Lock Washers and (2) 10mm Hex Nuts, **(Figure 15)**. Leave hardware loose at this time.
6. Select (1) Rear Tube Bracket, **(Figure 13)**. Bolt the Tube Bracket to the back of the Mounting Bracket with (2) 10mm x 30mm Hex Bolts, (4) 10mm Flat Washers and (2) 10mm Nylon Lock Nuts. **NOTE:** Cradles on all Brackets installed on the driver side will face the rear of the vehicle. Leave hardware loose at this time.
 7. Select the driver/left sidebar. With assistance, carefully position the Sidebar onto the (4) Mounting Brackets. **IMPORTANT:** Do not slide, (front to back or rotate), the Sidebar on the Brackets or damage to the finish on the Sidebar may result. Attach the

Sidebar to the Mounting Brackets with (8) 8mm x 25mm Hex Bolts, (8) 8mm Lock Washers and (8) 8mm Flat Washers, **(Figure 24)**. Do not tighten hardware.

8. Level and adjust the Sidebar and tighten all hardware.
9. Move to the passenger side of the vehicle. On the passenger side, determine if the vehicle is equipped with a plastic diesel exhaust fluid (DEF) tank, **(Figures 16 & 17)**.

Models without DEF tank, skip to Step 10.

Models with DEF tank: The tank sits close to the side of the body. With specialized tools, the passenger front upper and lower Bracket can be installed but room is limited. It may be easier to drop the tank down to access the inner side of the body panel for upper bracket installation. Tank will not need to be removed, only dropped down for access to mounting location. **IMPORTANT:** If tank is full, it will be very heavy and assistance is highly recommended to avoid injury or damage to the vehicle or the tank. It is recommended that installation is performed when the DEF tank is low on fluid and vehicle is on hard, level ground before dropping the tank.

- a. On models with plastic lower tray under the tank, remove the (3) hex bolts attaching the tray to the frame, **(Figure 16)**.
 - b. Release the tank filler hose. Release the plug for the sending unit on the top of the tank.
 - c. Support the tank with a floor jack. Place a smooth flat surface, (wooden block for example), between the floor jack and the tank to avoid damaging the plastic tank. Do not push up on the tank; only support the weight of the tank with the jack.
 - d. Remove the (2) bolts securing the tank straps to the vehicle, **(Figure 17)**. Tilt the straps to release from the brackets. Slowly lower the tank until the top of the tank is almost visible. Use blocks or stands to support the tank while installing the front Upper and Lower Brackets.
10. Locate the first tab on the edge of the pinch weld, **(Figures 2—4, 19 & 20B)**. Select the Upper Bracket, **(Figure 18)**. Repeat **Steps 2 & 3** to attach the passenger front Upper Bracket to the side of the body panel, **(Figure 19)**. Do not tighten hardware at this time.
 11. Line up the hole in the bottom of the Upper Bracket with the hole in the tab on the pinch weld.
 - a. **Models with a weld-nut:** Slide the Bracket over the weld-nut, **(Figure 19)**. Attach the Lower Bracket to the bottom of the body and weld-nut with (1) 8mm x 25mm Hex Bolt, (1) 8mm Lock Washer and (1) 8mm Flat Washer, **(Figures 21 & 22)**. Leave loose at this time.
 - b. **Models with flat tab and hole:** Insert the 8mm Bolt Plate down through the hole in the Upper Bracket and mounting tab, **(Figures 20A & 20B)**. Attach the Lower Bracket to the bottom of the body and Bolt Plate with (1) 8mm Flat Washer and (1) 8mm Nylon Lock Nut, **(Figures 21 & 22)**. Leave loose at this time.
 12. Line up the side tab on the Lower Bracket with the threaded hole in the side of the Upper Bracket. Attach the Lower Bracket to the Upper Bracket with (1) 8mm x 25mm Hex Bolt, (1) 8mm Lock Washer and (1) 8mm Flat Washer, **(Figure 22)**. Leave loose at this time.
 13. Repeat **Steps 1—3** for the (2) remaining passenger side cab Bracket installations.
 14. Repeat the appropriate **Step 5** to install (1) Bed Mounting Bracket on the passenger side. Select (1) Rear Tube Bracket, **(Figure 23)**. Bolt the Tube Bracket to the front of the Mounting Bracket with (2) 10mm x 30mm Hex Bolts, (4) 10mm Flat Washers and (2) 10mm Nylon Lock Nuts. **NOTE:** Cradles on all Brackets installed on passenger side will face forward. Leave hardware loose at this time.
 15. Repeat **Steps 7 & 8** to install the passenger Sidebar, **(Figure 24)**.
 16. Once the Sidebars are installed and all hardware fully tightened, reinstall the DEF tank and cover, if equipped, as described in **Step 9**.
 17. Do periodic inspections to the installation to make sure that all hardware is secure and tight.

Driver/Left Side Installation Pictured

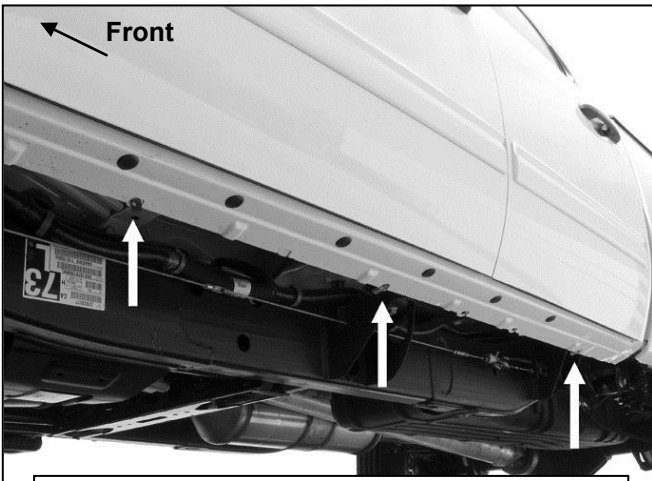

(Fig 1) Driver side (3) cab mounting locations

Factory 8mm threaded insert in body panel

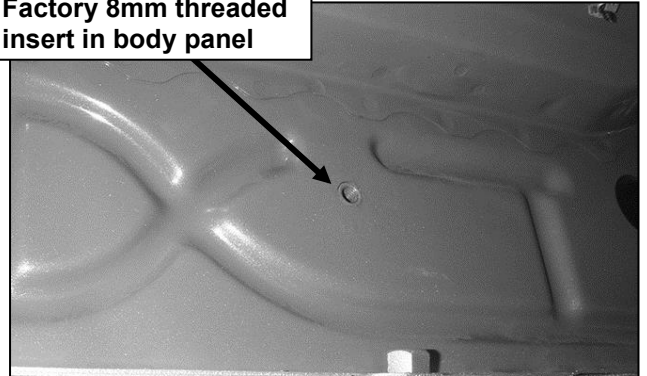

8mm Weld Nut

Front

(Fig 2) Passenger side front mounting location

Factory 8mm threaded insert in body panel

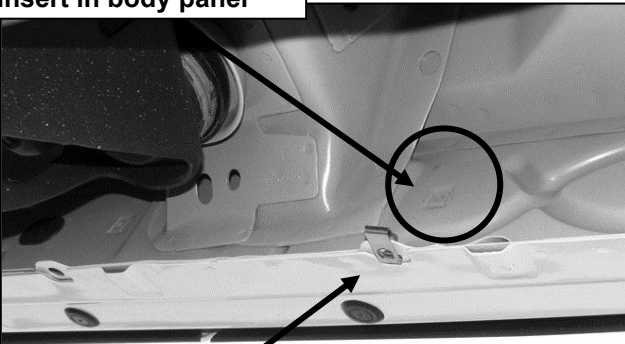

8mm Clip Nut

Front

(Fig 3) Driver side 2nd mounting location

Remove plug

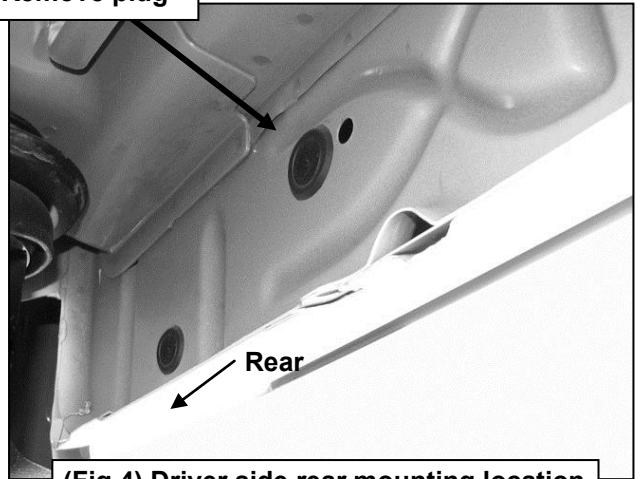

(Fig 4) Driver side rear mounting location

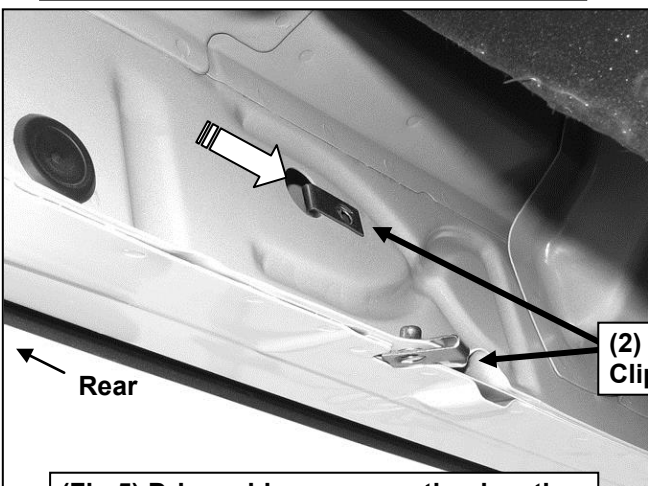

(2) 8mm Clip Nuts

(Fig 5) Driver side rear mounting location

Driver/Left Side Installation Pictured

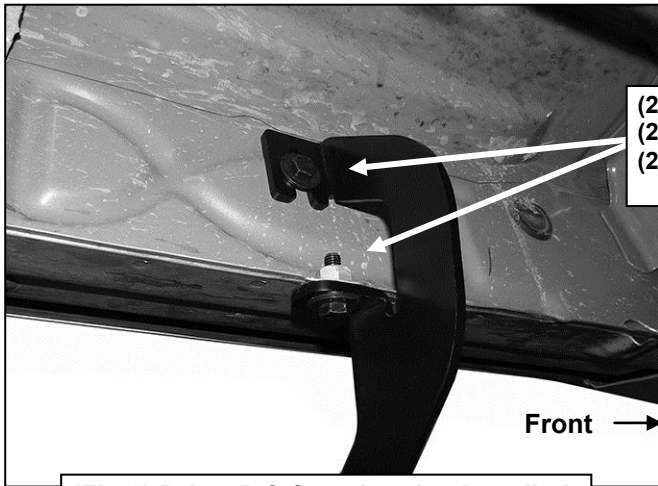

- (2) 8mm x 25mm Hex Bolts
- (2) 8mm Lock Washers
- (2) 8mm Flat Washers

(Fig 6) Driver/left front bracket installed

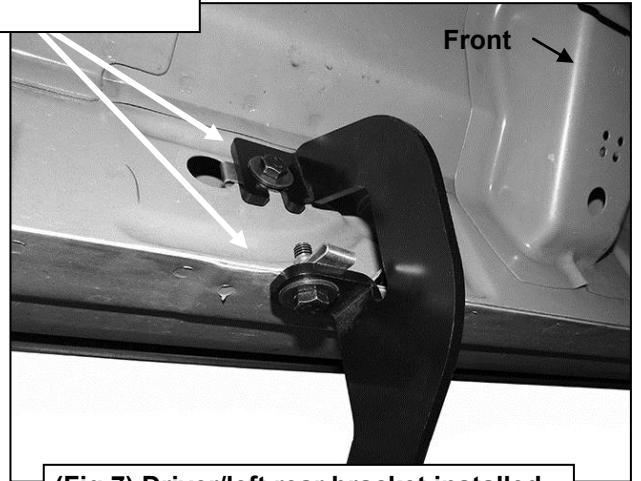

(Fig 7) Driver/left rear bracket installed

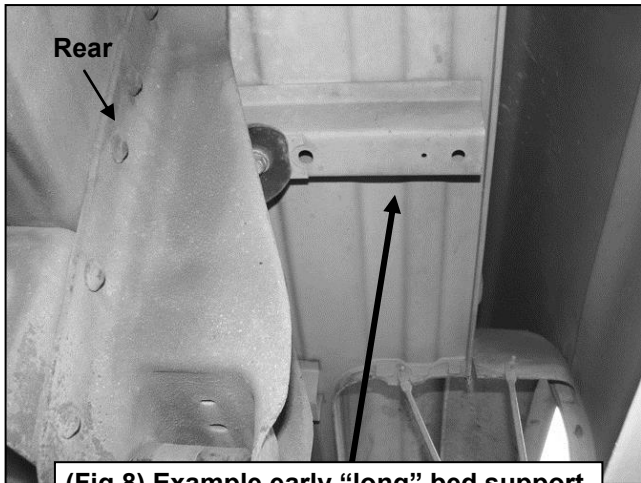

(Fig 8) Example early "long" bed support

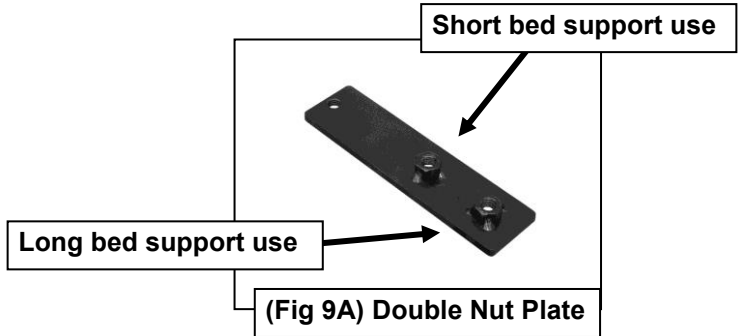

(Fig 9A) Double Nut Plate

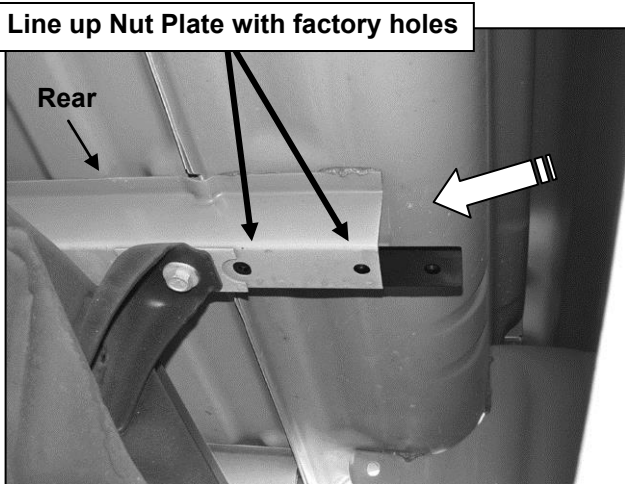

(Fig 9B) Late "short open end" bed support

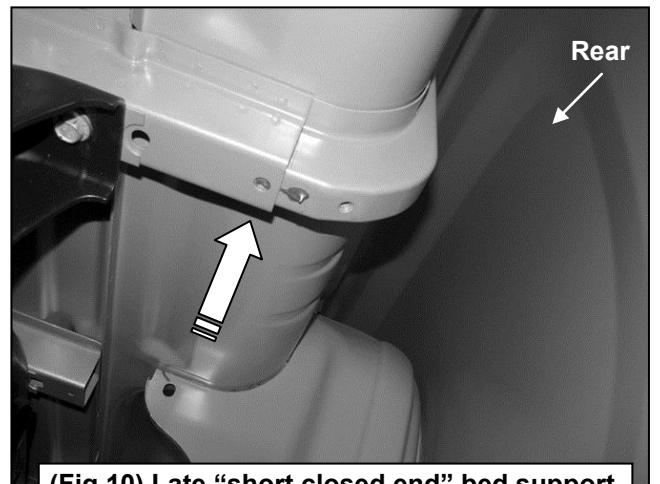

(Fig 10) Late "short closed end" bed support

Driver/Left Side Installation Pictured



(Fig 11) Use 1/2" drill bit to open blocked off hole in bed support. Do not drill through bottom of bed

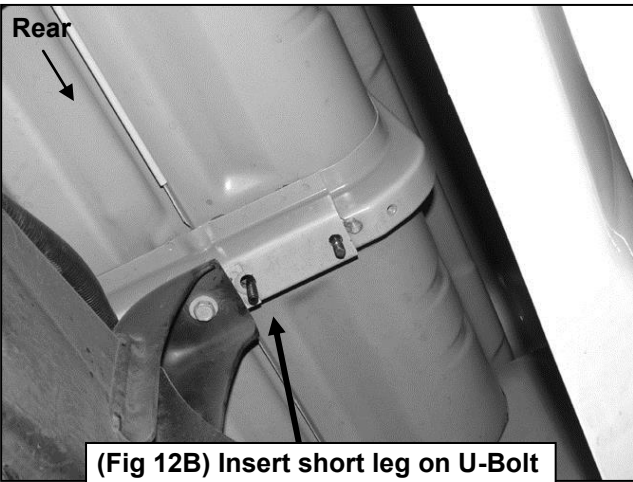

(Fig 12B) Insert short leg on U-Bolt into one hole and back out other



(Fig 14) Bolt Bed Bracket to Double Nut Plate

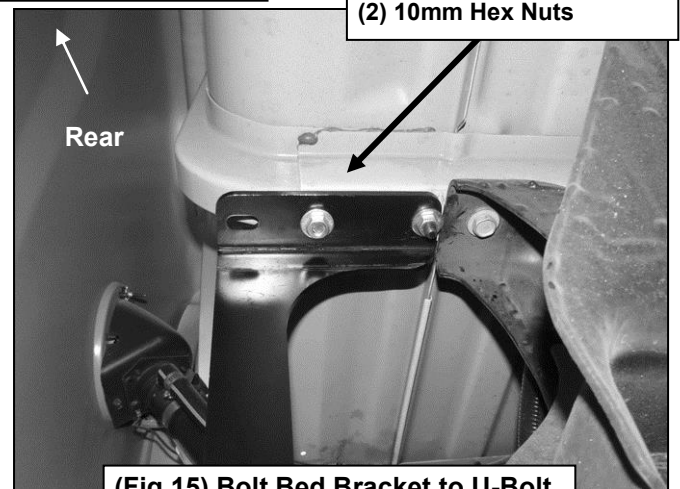

(Fig 15) Bolt Bed Bracket to U-Bolt



(Fig 12A) 10mm U-Bolt

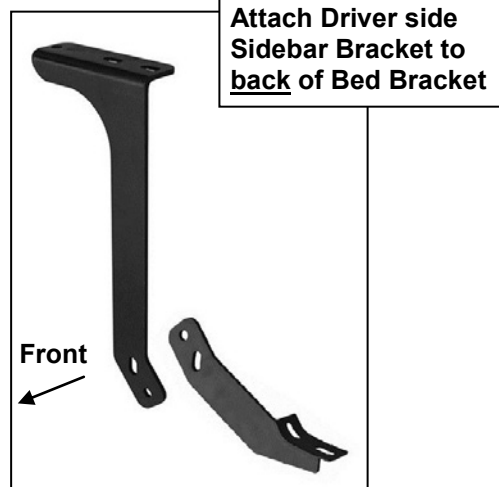

(Fig 13) Driver side Bed Bracket and Sidebar Bracket illustrated

- (2) 10mm x 30mm Hex Bolts
- (2) 10mm Lock Washers
- (2) 10mm Flat Washers

- (2) 10mm Flat Washers
- (2) 10mm Lock Washers
- (2) 10mm Hex Nuts

Passenger/right Side Installation Pictured

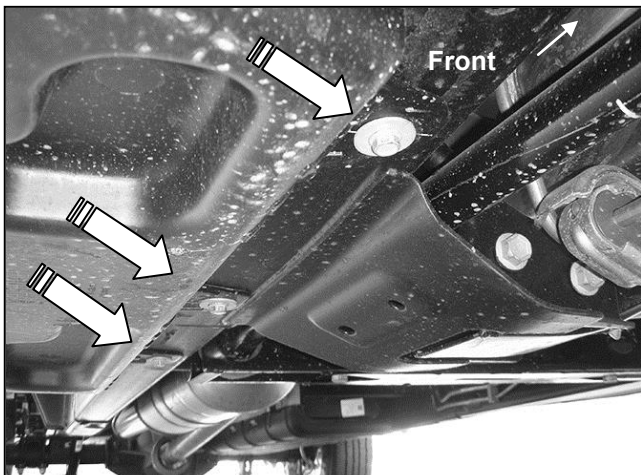

(Fig 16) Passenger side front pictured with DEF tank cover. Remove (3) hex bolts to remove cover

Remove (2) factory bolts to remove tank straps

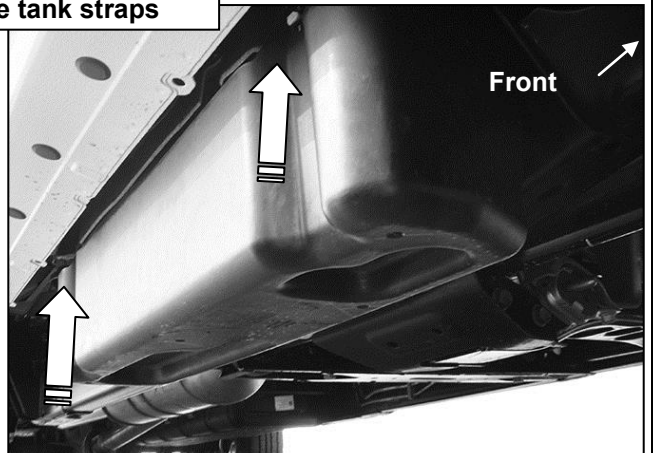

(Fig 17) Passenger side DEF tank and cover



(Fig 18) Passenger/right Front Upper Bracket (all models)

**8mm x 25mm Hex Bolt
8mm Lock Washer
8mm Flat Washer**

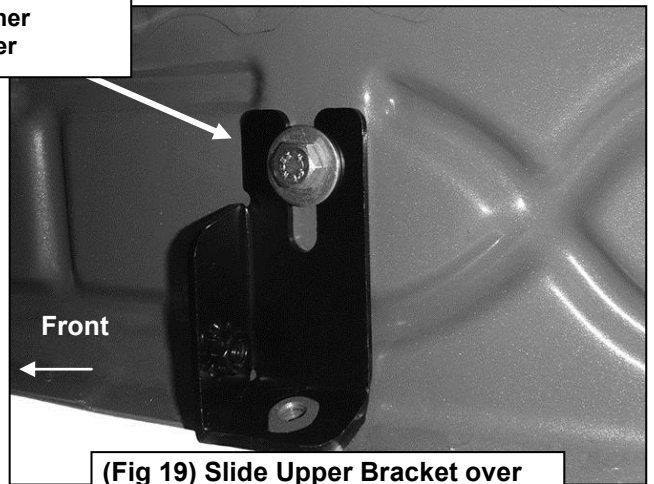

(Fig 19) Slide Upper Bracket over weld nut (if equipped-see Figure 2)



(Fig 20A) 8mm x 35mm Bolt Plate

On models with flat tab (see Fig. 3, 4 and 16), insert 8mm Bolt Plate (Fig 13) down through Upper Bracket and mounting tab

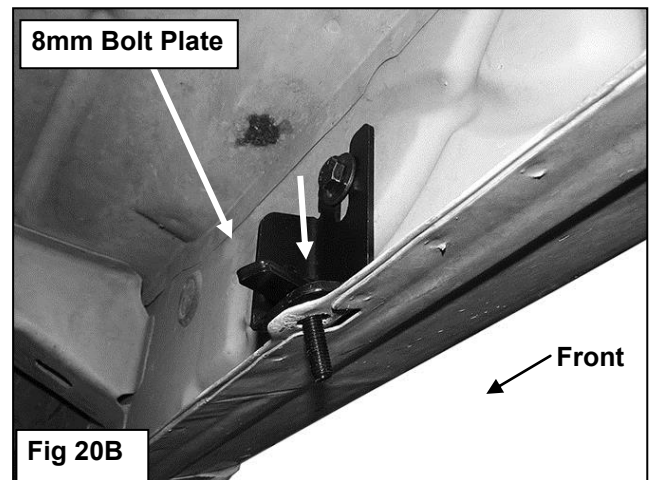

Fig 20B

Passenger/Right Side Installation Pictured



(Fig 21) Passenger/right Front only Lower Bracket

8mm x 25mm Hex Bolt
8mm Lock Washer
8mm Flat Washer

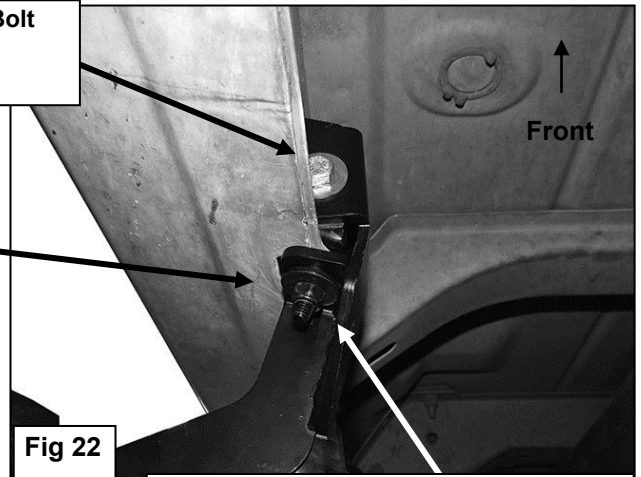
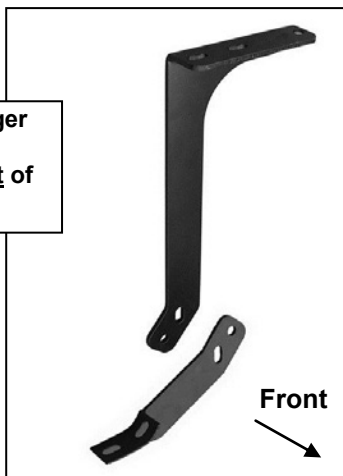

Fig 22

Models with weld nut on tab use:
8mm x 25mm Hex Bolt
8mm Lock Washer
8mm Flat Washer
to attach Lower Bracket to weld nut

Attach Passenger side Sidebar Bracket to front of Bed Bracket



(Fig 23) Passenger side Bed Bracket and Sidebar Bracket illustrated

On models with flat tab and 8mm Bolt Plate (see Fig. 20B) use:
8mm Flat Washer
8mm Nylon Lock Nut
to attach Lower Bracket to Bolt Plate

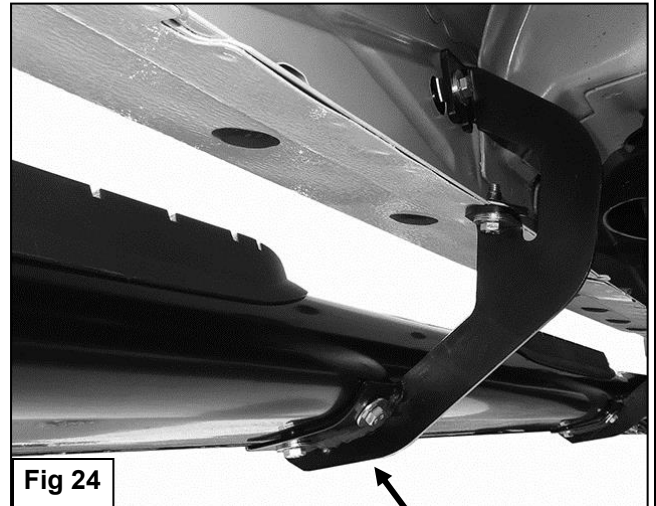

Fig 24

(2) 8mm x 25mm Hex Bolts
(2) 8mm Lock Washers
(2) 8mm Flat Washers



Complete Installation

PARTS IDENTIFICATION GUIDE

Driver Side tube packed using "Green" color foam sheet. Passenger Side tube packed using "White" color foam sheet

No.	Parts Identification
1	Passenger / Right 'Rear' Bracket marked "PR"
2	Driver / Left 'Rear' Bracket marked "DR"
3	Passenger / Right 'Center' Bracket marked "PC"
4	Driver / Left 'Center' Bracket marked "DC"
5	Passenger / Right 'Front' Bracket marked "PF"
6	Driver / Left 'Front' Bracket marked "DF"

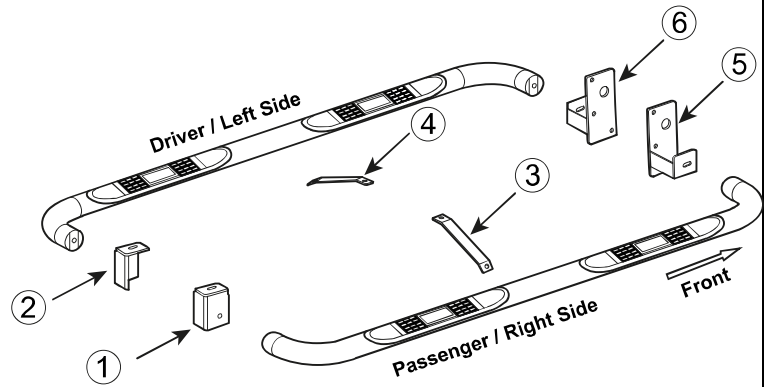

Note:

- This guide is to identify the parts and not a reference for part count.
- For part count, refer Parts List.
- Product / Bracket image is representative and actual design may vary.

PRODUCT CARE

- Periodically check the product to ensure all fasteners are tight and components are intact.
- Regular waxing is recommended to protect the finish of the product.
- **Use ONLY Non-Abrasive automotive wax.** Use of any soap, polish or wax that contains an abrasive is detrimental and can scratch the finish leading to corrosion.
- Aluminum polish may be used to polish small scratches and scuffs for **Stainless Steel finish.**
- Mild soap may be used to clean the product for both **Stainless Steel and Black finish.**

1. Hardware's are not of correct size.

In GMC / Chevrolet truck model 2006 & up, customer needs to reuse the factory body bolts to install the bracket. If your vehicle is not GMC / Chevrolet 2006 & up, ensure that holes are not partially covered with any plastic grommet or rust? If it is, remove the plastic grommet & rust from the thread holes & re-try the installation.

2. Mounting Bracket are not getting Installed properly.

In some cases Illustration images shown in Installation manual may not be the exactly same as per actual vehicle images ,also if Driver / Passenger side mounting brackets are very identical in the design, suggest referring Parts Identification guide to avoid fitment issue.

3. Products are thumping / rattling after installation.

Ensure that all required mounting brackets / hardware's are installed & tighten correctly. Suggest using white lithium / regular grease between the metal to metal contact surfaces.

4. Side Bar is not aligning with vehicle / Step Pads are not aligning with vehicle doors.

Side bar may be interchanged or mounting brackets are not installed at the correct position in the vehicle. Refer Parts identification guide.

5. Missing / Excess Hardware.

Recheck hardware count as per the part list.

6. Product not installing properly.

Ensure make model year, cab length and bed size of your vehicle is listed in the application. All installation steps are followed correctly.