

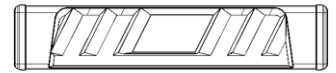

4" Side Bar

Part No. A5006S



Fits: 1999-2016 Ford Superduty With 8Ft Long Bed



REMOVE CONTENTS FROM BOX. VERIFY ALL PARTS ARE PRESENT.



READ INSTRUCTIONS CAREFULLY BEFORE STARTING INSTALLATION.



DO NOT OVER TORQUE. STANDARD OPERATING LOAD FOR TIGHTEN BODY MOUNT NUTS & BOLTS VARIES FROM 45 TO 65 FOOT POUND.



60-180 min



CUTTING NOT
REQUIRED



DRILLING
REQUIRED

PARTS LIST:

Qty	Part Description	Qty	Part Description
1	Driver/Left Side Box Board	8	10mm Bolt Plates
1	Passenger/Right Side Box Board	8	10mm x 27mm x 3mm Flat Washers
1	Driver/Left Side Front Mounting Bracket	8	10mm Hex Nuts
1	Passenger/Right Side Front Mounting Bracket	8	10mm Lock Washers
1	Driver/Left Side Rear Mounting Bracket	2	10mm Fish Wires
1	Passenger/Right Side Rear Mounting Bracket	8	8mm Nylon Lock Nuts
1	Driver/Left Side Front Box Bracket	16	8mm x 24mm x 2mm Flat Washers
1	Passenger/Right Side Front Box Bracket	8	8-1.25mm x 30mm Hex Bolts
1	Driver/Left Side Rear Box Bracket	8	8mm Combo Bolts
1	Passenger/Right Side Rear Box Bracket	8	8mm Plastic Clips
		4	Plastic Covers

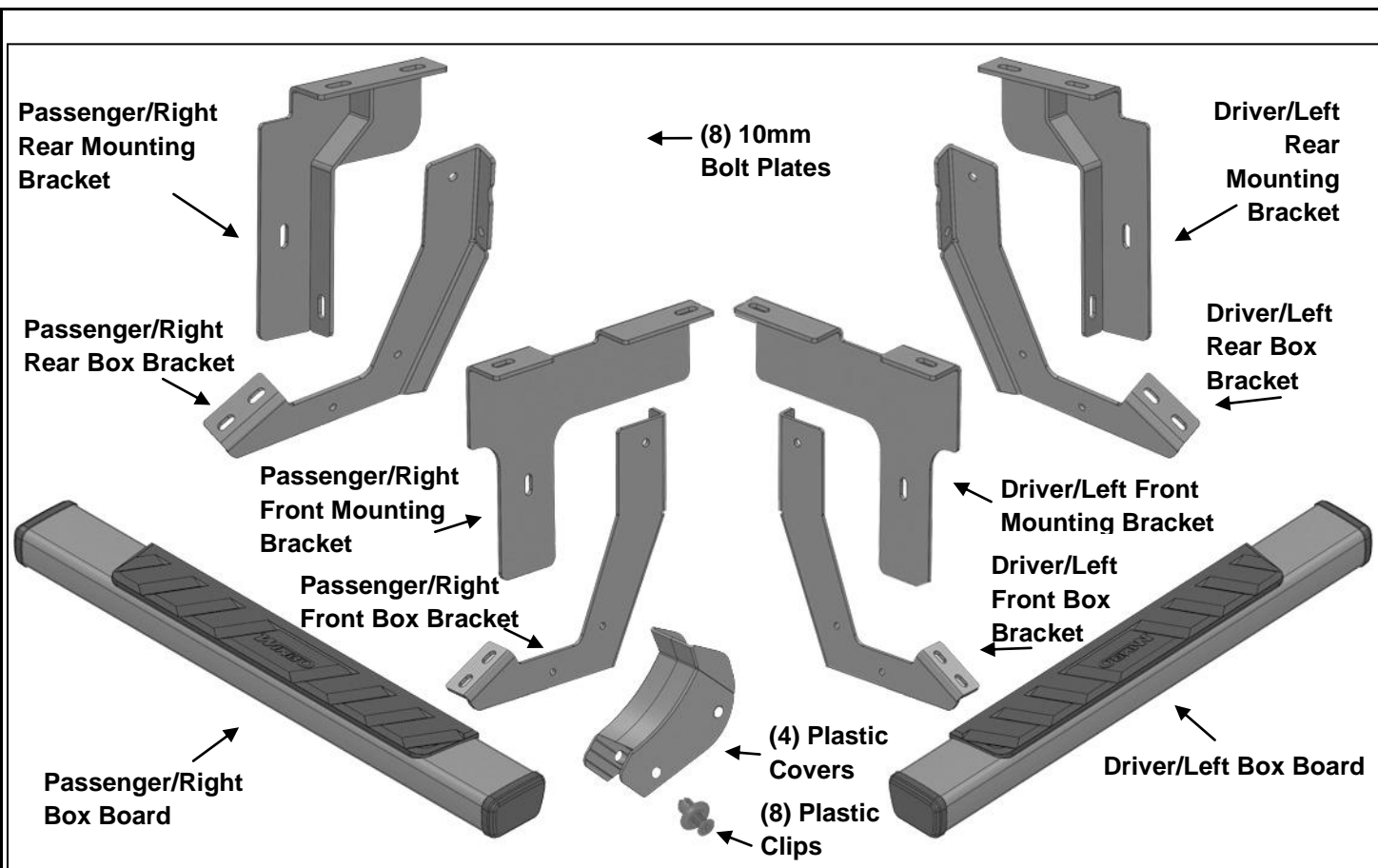

PROCEDURE:

REMOVE CONTENTS FROM BOX. VERIFY ALL PARTS ARE PRESENT. READ INSTRUCTIONS CAREFULLY BEFORE STARTING INSTALLATION. ASSISTANCE IS RECOMMENDED. DRILLING IS REQUIRED.

1. Starting on the driver side of the vehicle, locate the square reinforcing channel welded to the bottom of the bed above and in front of the rear tire, **(Figures 1 & 8)**.
 - 1999-2010 models:**
 - a. Select the driver side Rear Mounting Bracket. Align the bracket with the inner oval hole in the square reinforcing channel. Place a mark for a second hole on the bottom of the square reinforcing channel for drilling **(Figure 1)**. Drill the mark with a 1/2" Drill Bit.
 - b. To install the (1) 10mm Bolt Plate into the factory hole, select (1) 10mm Fish Wire. Leave the length of the Bolt Plate coiled and uncoil the rest of the Fish Wire. Hold onto the uncoiled end of the Fish Wire and insert the coiled end in through the factory oval hole and out of the rectangular channel, **(Figures 2—3)**. Thread the coiled end of the fish wire onto (1) 10mm Bolt Plate, **(Figures 4—5)**. Gently pull the coil back into the rectangular channel until the plate sits flatly on top of the opening of the factory hole. Unthread Fish Wire from Bolt Plate, **(Figure 6)**.
 - c. Insert (1) 10mm Bolt Plate through the channel and out through the drilled hole using the fish wire as necessary, **(Figure 6)**.
 - 2011-2016 models:**
 - a. Release the plastic vent tube from the from the plastic vent holder. Remove the factory screw from the side of channel, **(Figure 8)**. Pull the plastic vent tube holder out of channel, **(Figure 9)**.
 - b. Select the driver side Rear Mounting Bracket. Align the bracket with the inner hole in the square reinforcing channel. Place a mark for a second hole on the bottom of the square reinforcing channel for drilling, **(Figure 10)**. Drill the mark with a 1/2" Drill Bit.
 - c. To install the (1) 10mm Bolt Plate into the factory hole. Select (1) 10mm Fish Wire. Leave the length of the Bolt Plate coiled and uncoil the rest of the Fish Wire. Hold onto the uncoiled end of the Fish

Wire and insert the coiled end in through the factory oval hole and out of the rectangular channel, **(Figures 2—3)**. Thread the coiled end of the fish wire onto (1) 10mm Bolt Plate, **(Figures 4—5)**. Gently pull the coil back into the rectangular channel until the plate sits flatly on top of the opening of the factory hole. Unthread Fish Wire from Bolt Plate, **(Figure 6)**.

- d. Insert (1) 10mm Bolt Plate through the channel and out through the drilled hole. Reinstall the plastic bracket and factory screw, **(Figures 11—12)**.
2. Hang the driver side rear Mounting Bracket from the (2) 10mm Bolt Plates with (2) 10mm Flat Washers, (2) 10mm Lock Washers and (2) 10mm Hex Nuts, **(Figures 13—14)**. Snug but do not tighten.
3. Select the driver side rear Box Bracket. Bolt the Bracket to the Mounting Bracket with (2) 8mm Hex Bolts, (4) 8mm Flat Washers and (2) 8mm Nylon Lock Nuts, **(Figures 13 & 15)**. Leave loose.
4. Move along the cab toward the driver side front mounting location, **(Figure 16)**. Select (2) 10mm Bolt Plates. Insert the (2) 10mm Bolt Plates into the square opening of the channel and thread the bolts through the 1st and 4th hole using Fish Wire as necessary, **(Figure 17)**. Hang the driver side front Mounting Bracket from the (2) 10mm Bolt Plates with (2) 10mm Flat Washers, (2) 10mm Lock Washers and (2) 10mm Hex Nuts, **(Figures 18—19)**. Snug but do not tighten hardware at this time.
5. Select the driver side front Box Bracket. Attach the driver side front Box Bracket to the driver side front Mounting Bracket with (2) 8mm Hex Bolts, (4) 8mm Flat Washers and (2) 8mm Nylon Lock Nuts, **(Figures 18 & 20)**. **NOTE:** Bracket cradles must be facing towards the rear. Leave loose.
6. Select (1) Plastic Bracket Cover and (2) Plastic Clips. Slide the Plastic Cover over the Box Bracket. Line up the holes in the Cover with the holes in the Bracket. Attach the Cover to the Bracket with the included (2) Plastic Clips, **(Figures 21—22)**. Push the Clip into the hole and push the center pin in to expand the Clip in the hole in the Bracket. Repeat this Step to install driver side Plastic Covers.
7. Select the driver side T4 Box Board. **Note:** Front inserts in bottom of Tube are farther from the end of the tube, **(Figure 23)**. Attach the Box Board to the Brackets with (4) 8mm Combo Bolts, **(Figure 24)**. Leave hardware loose at this time.
8. Level and adjust the Box Board and tighten all hardware.
9. Repeat **Steps 1—8** for passenger side Box Board installation.
10. Do periodic inspections to the installation to make sure that all hardware is secure and tight

Driver/Left Side Installation Pictured

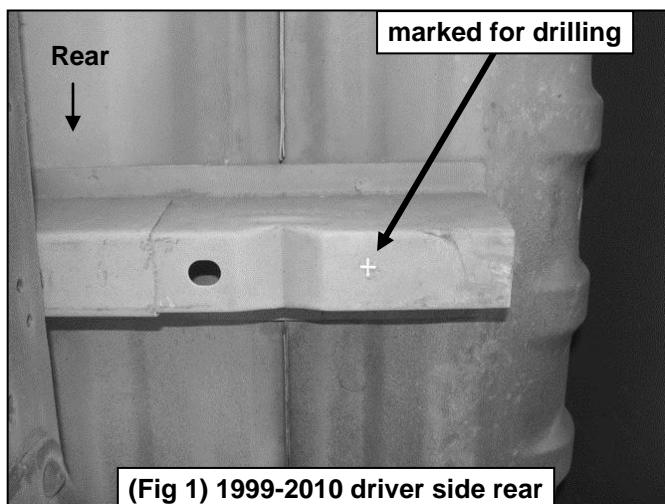

(Fig 1) 1999-2010 driver side rear bracket location pictured

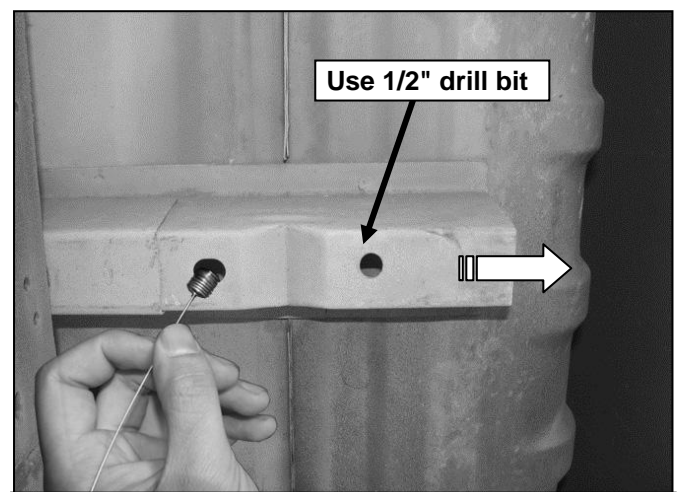

(Fig 2) Insert coiled end of Fish Wire into oval hole

Driver/Left Side Installation Pictured

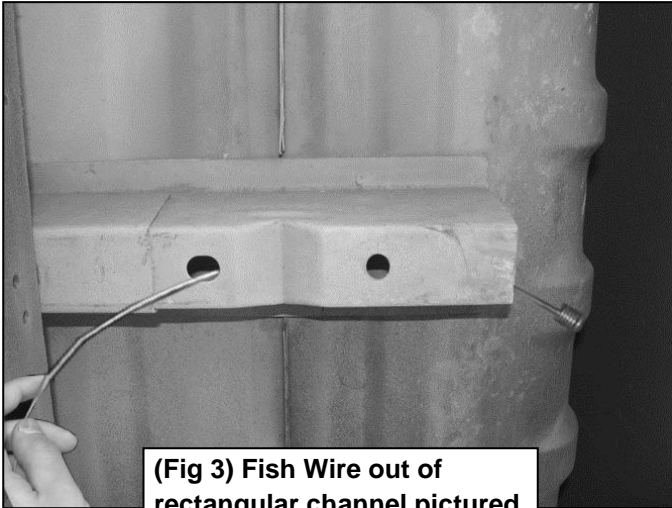

(Fig 3) Fish Wire out of rectangular channel pictured



(Fig 4) 10mm Bolt Plate

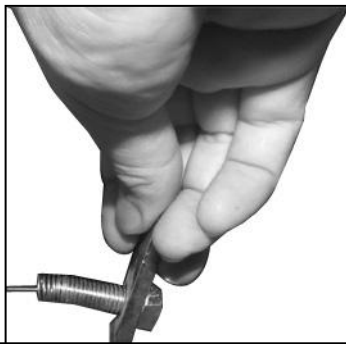

(Fig 5) Thread coiled end of Fish Wire onto Bolt Plate

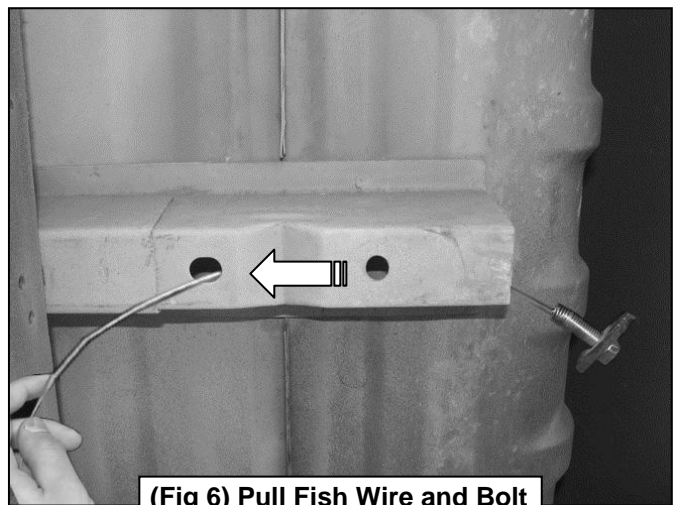

(Fig 6) Pull Fish Wire and Bolt Plate back into the oval hole

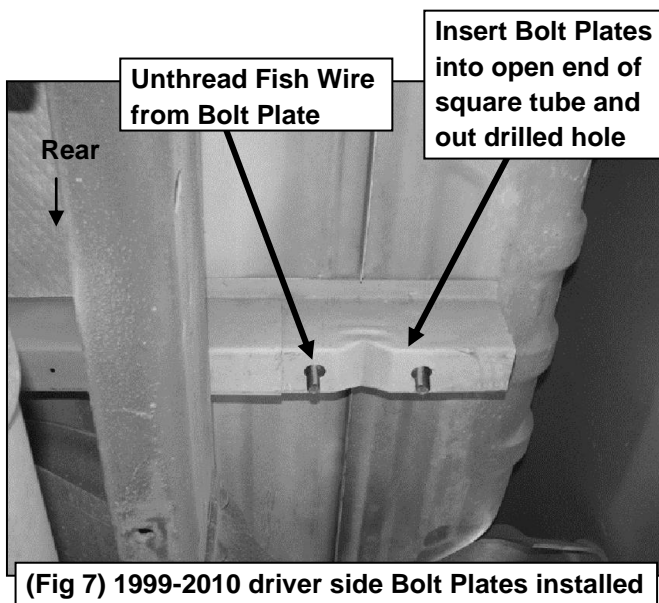

(Fig 7) 1999-2010 driver side Bolt Plates installed

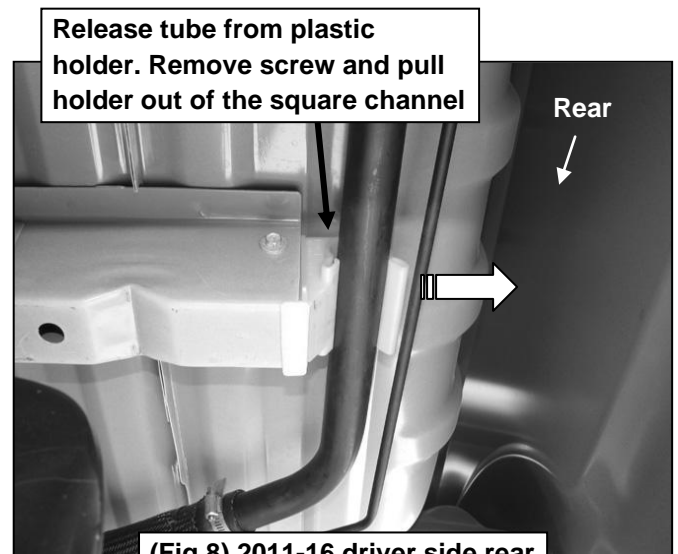

(Fig 8) 2011-16 driver side rear bracket location pictured

Driver/Left Side Installation Pictured

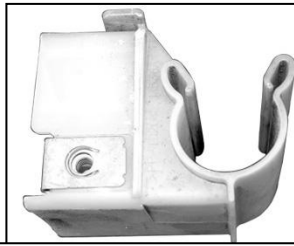

(Fig 9) 2011-16 plastic vent tube holder removed

Insert Bolt Plates into open end of square tube and out factory hole (See Fig 2—7 on how to use fish wire)

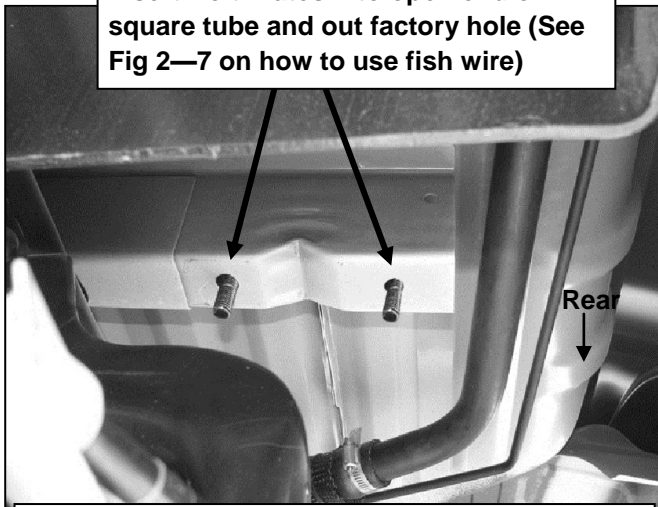

(Fig 11) 2011-16 driver side Bolt Plates Installed

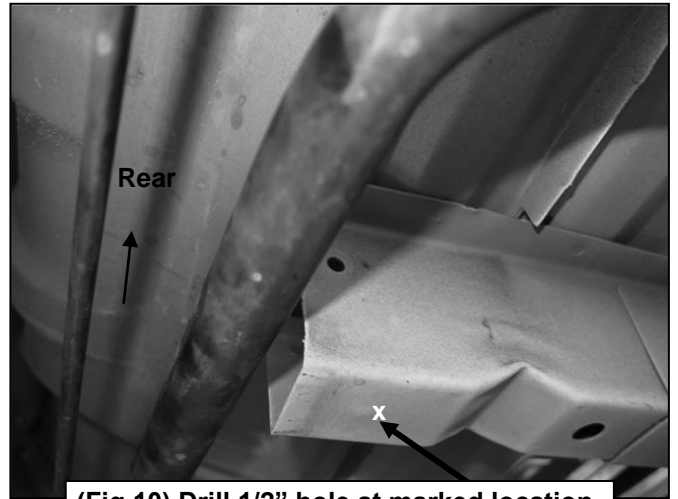

(Fig 10) Drill 1/2" hole at marked location

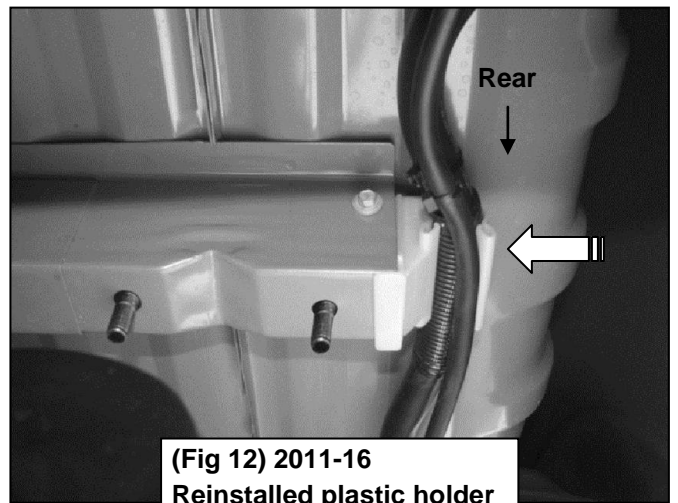

(Fig 12) 2011-16 Reinstalled plastic holder

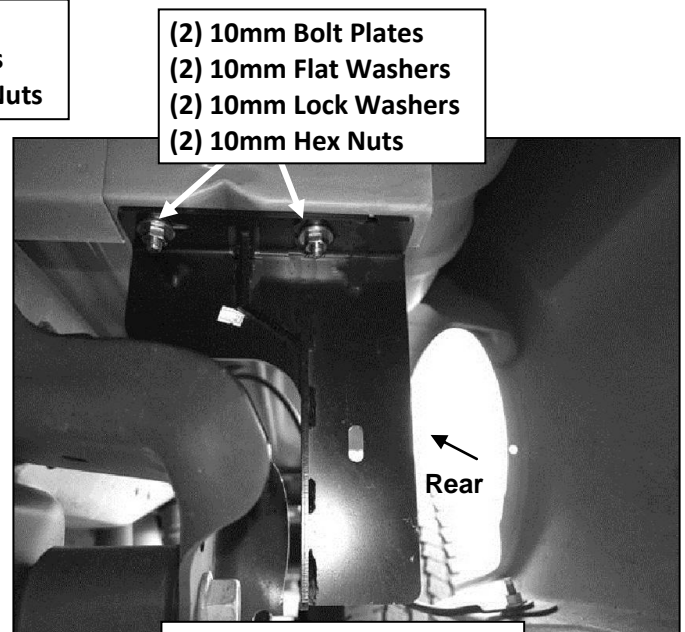
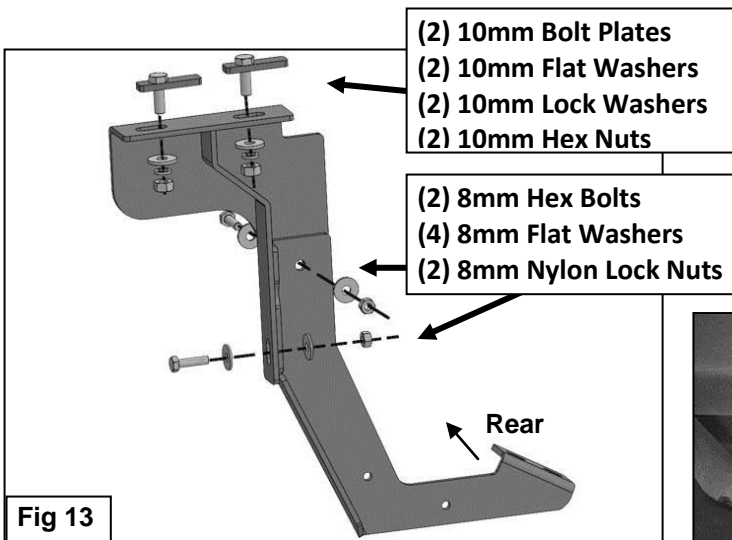

(Fig 14) Driver side rear Mounting Bracket Installed

Driver/Left Side Installation Pictured

- (2) 8mm Hex Bolts
- (4) 8mm Flat Washers
- (2) 8mm Nylon Lock Nuts

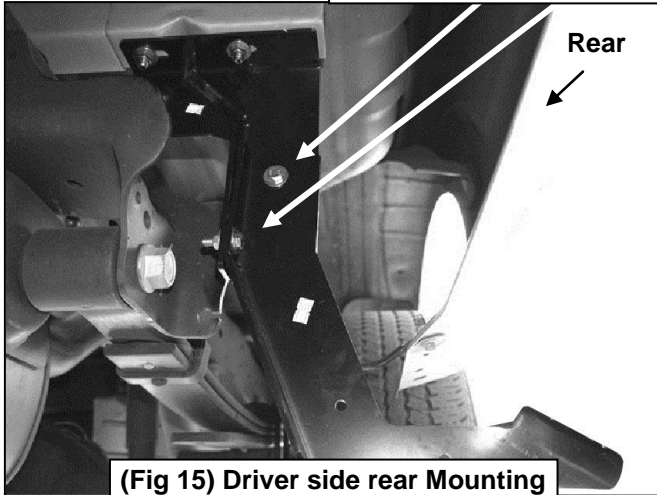

(Fig 15) Driver side rear Mounting and Box Bracket Installed

Mounting Points: 1st and 4th hole

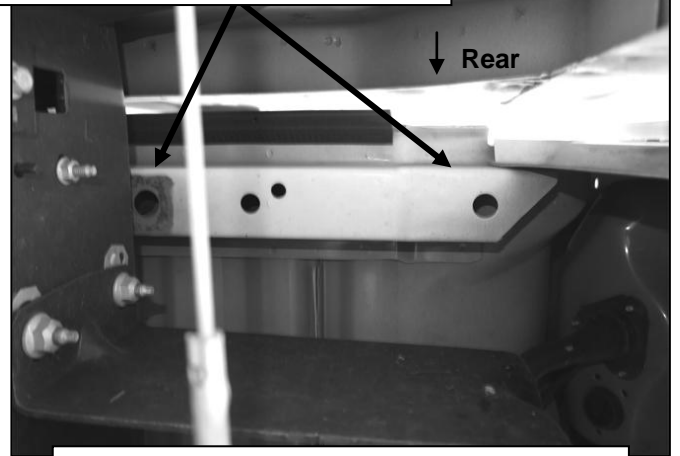

(Fig 16) driver side front mounting location

Insert (2) Bolt Plates using Fish Wire as necessary

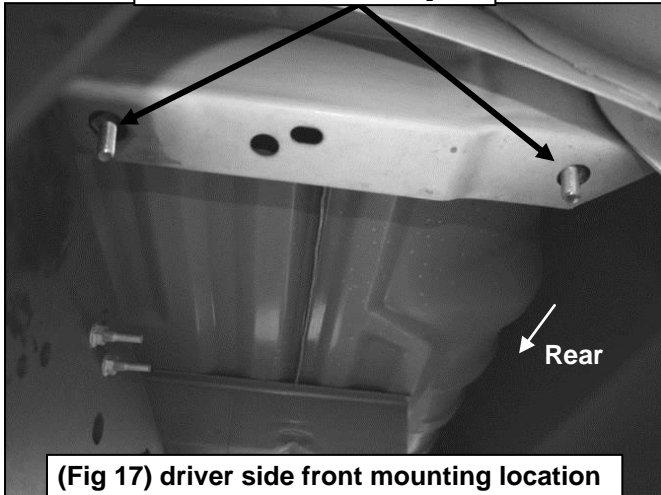

(Fig 17) driver side front mounting location

- (2) 10mm Bolt Plates
- (2) 10mm Flat Washers
- (2) 10mm Lock Washers
- (2) 10mm Hex Nuts

- (2) 8mm Hex Bolts
- (4) 8mm Flat Washers
- (2) 8mm Nylon Lock Nuts

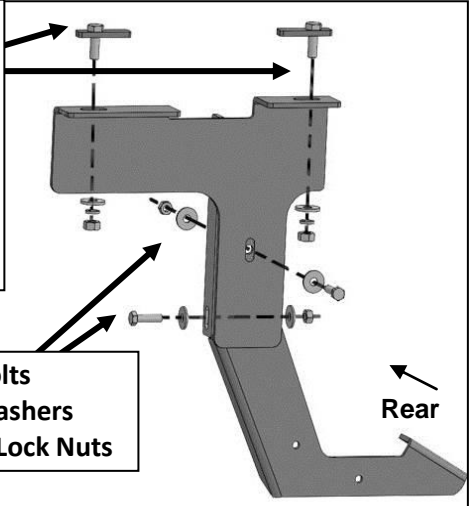
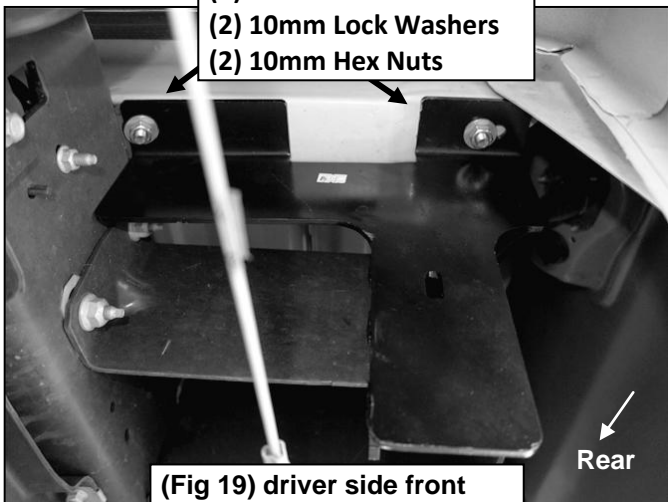

Fig 18

- (2) 10mm Bolt Plates
- (2) 10mm Flat Washers
- (2) 10mm Lock Washers
- (2) 10mm Hex Nuts

- (2) 8mm Hex Bolts
- (4) 8mm Flat Washers
- (2) 8mm Nylon Lock Nuts



(Fig 19) driver side front Mounting Bracket installed

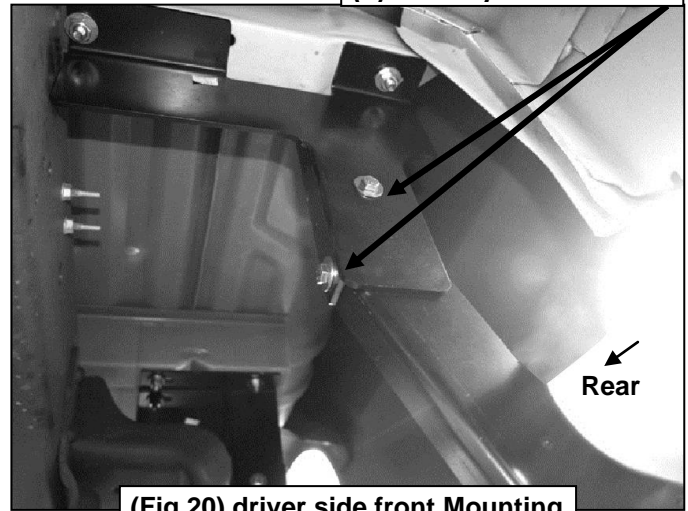

(Fig 20) driver side front Mounting and Bed Bracket installed

Driver/Left Side Installation Pictured

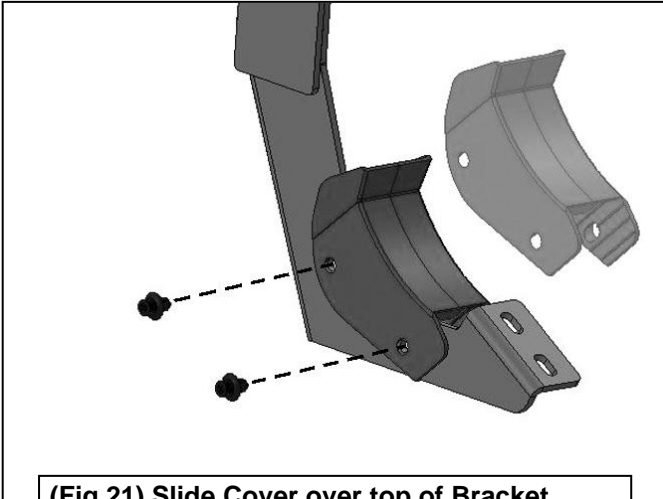

(Fig 21) Slide Cover over top of Bracket. Attach Cover to Bracket with (2) Plastic Clips

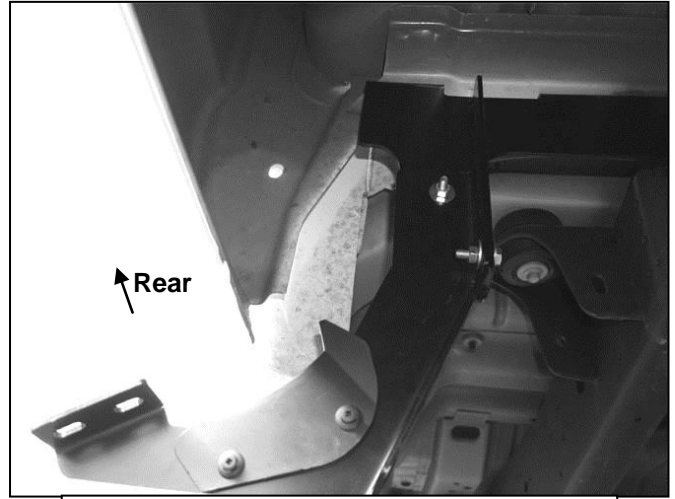

(Fig 22) driver side Plastic Cover installed

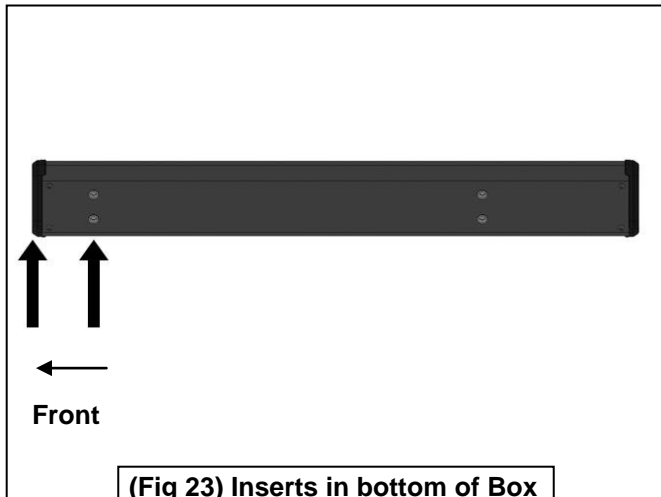

(Fig 23) Inserts in bottom of Box Board are closer to front end

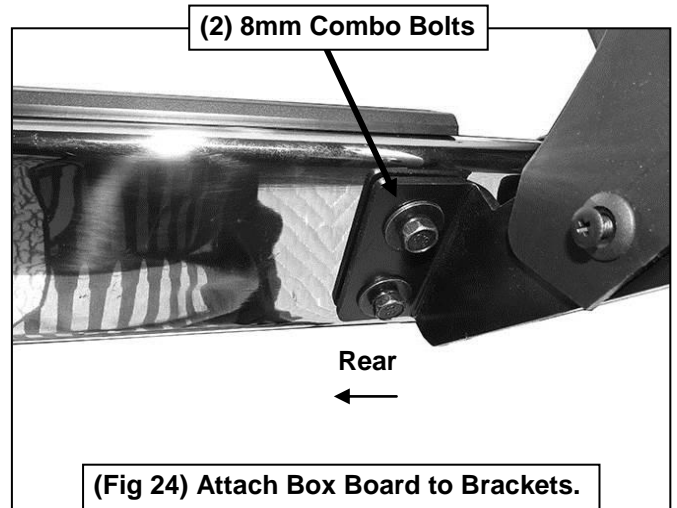

(Fig 24) Attach Box Board to Brackets. Note: All cradles must face rear



Complete Installation

PARTS IDENTIFICATION GUIDE

Driver Side tube packed using "Green" color foam sheet. Passenger Side tube packed using "White" color foam sheet

No.	Parts Identification
1	Passenger / Right „Rear“ Bracket marked "PR"
2	Driver / Left „Rear“ Bracket marked "DR"
3	Passenger / Right „Center“ Bracket marked "PC"
4	Driver / Left „Center“ Bracket marked "DC"
5	Passenger / Right „Front“ Bracket marked "PF"
6	Driver / Left „Front“ Bracket marked "DF"

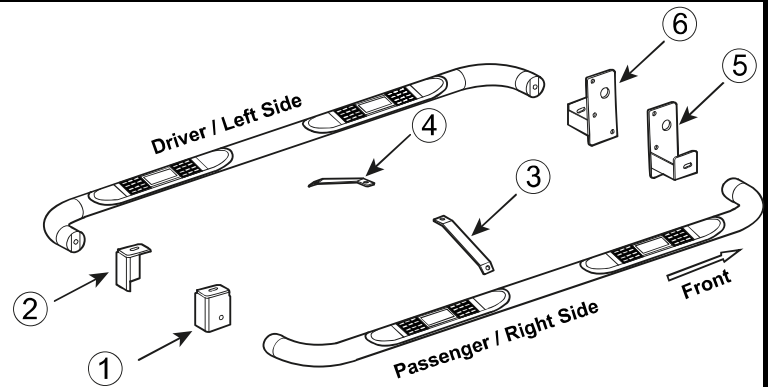

Note:

- This guide is to identify the parts and not a reference for part count.
- For part count, refer Parts List.
- Product / Bracket image is representative and actual design may vary.

PRODUCT CARE

- Periodically check the product to ensure all fasteners are tight and components are intact.
- Regular waxing is recommended to protect the finish of the product.
- **Use ONLY Non-Abrasive automotive wax.** Use of any soap, polish or wax that contains an abrasive is detrimental and can scratch the finish leading to corrosion.
- Aluminum polish may be used to polish small scratches and scuffs for **Stainless Steel finish.**
- Mild soap may be used to clean the product for both **Stainless Steel and Black finish.**

FAQ's

1. Hardware's are not of correct size.

In GMC / Chevrolet truck model 2006 & up, customer needs to reuse the factory body bolts to install the bracket. If your vehicle is not GMC / Chevrolet 2006 & up, ensure that holes are not partially covered with any plastic grommet or rust? If it is, remove the plastic grommet & rust from the thread holes & re-try the installation.

2. Mounting Bracket are not getting Installed properly.

In some cases Illustration images shown in Installation manual may not be the exactly same as per actual vehicle images ,also if Driver / Passenger side mounting brackets are very identical in the design, suggest referring Parts Identification guide to avoid fitment issue.

3. Products are thumping / rattling after installation.

Ensure that all required mounting brackets / hardware's are installed & tighten correctly. Suggest using white lithium / regular grease between the metal to metal contact surfaces.

4. Side Bar is not aligning with vehicle / Step Pads are not aligning with vehicle doors.

Side bar may be interchanged or mounting brackets are not installed at the correct position in the vehicle. Refer Parts identification guide.

5. Missing / Excess Hardware.

Recheck hardware count as per the part list.

6. Product not installing properly.

Ensure make model year, cab length and bed size of your vehicle is listed in the application. All installation steps are followed correctly.

Check out these other TrailFX Products!!



BULL BAR



GRILLE GUARDS



BED RAILS



RUNNING BOARDS

Keystone Automotive Operations Inc. (KAO) warrants this product to be free of defects in material and workmanship at the time of purchase by the original retail consumer. KAO disclaims any other warranties, express or implied, including the warranty of fitness for a particular purpose or an intended use. If the product is found to be defective, KAO may replace or repair the product at our option, when the product is returned prepaid, with proof of purchase. Alteration to, improper installation, or misuse of this product voids the warranty. KAO's liability is limited to repair or replacement of products found to be defective, and specifically excludes liability for any incidental or consequential loss or damage.