

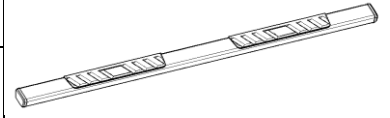

4" Side Bar

Part No. A4011S



Fits: 2009 - Current Dodge Ram 1500 Quad Cab



60-180 min

Cutting Not Required

Drilling Not Required



REMOVE CONTENTS FROM BOX. VERIFY ALL PARTS ARE PRESENT.



READ INSTRUCTIONS CAREFULLY BEFORE STARTING INSTALLATION.

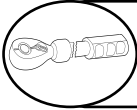

DO NOT OVER TORQUE. STANDARD OPERATING LOAD FOR TIGHTEN BODY MOUNT NUTS & BOLTS VARIES FROM 45 TO 65 FOOT POUND.

PARTS LIST:

Qty	Part Description	Qty	Part Description
1	Driver/Left Side Step	12	8-1.25mm x 30 Hex Bolts
1	Passenger/Right Side Step	12	8mm x 24mm x 2mm Flat Washers
3	Driver/left Front Bracket (also fits passenger/right center and rear locations)	12	8mm Lock Washers
3	Passenger/right Front Bracket (also fits driver/left center and rear locations)	6	8mm Hex Nuts
6	Plastic Bracket Covers	12	8-1.25mm x 25mm Combo Hex Bolts
12	Plastic Clips for Covers	12	6-1.0mm x 25mm Socket Head Bolt
6	8mm Nut/Bolt Plates	24	6mm x18mm x 1.6mm Flat Washers
6	8mm Plastic Retainers	12	6mm Flange Nuts
		1	Allen Key

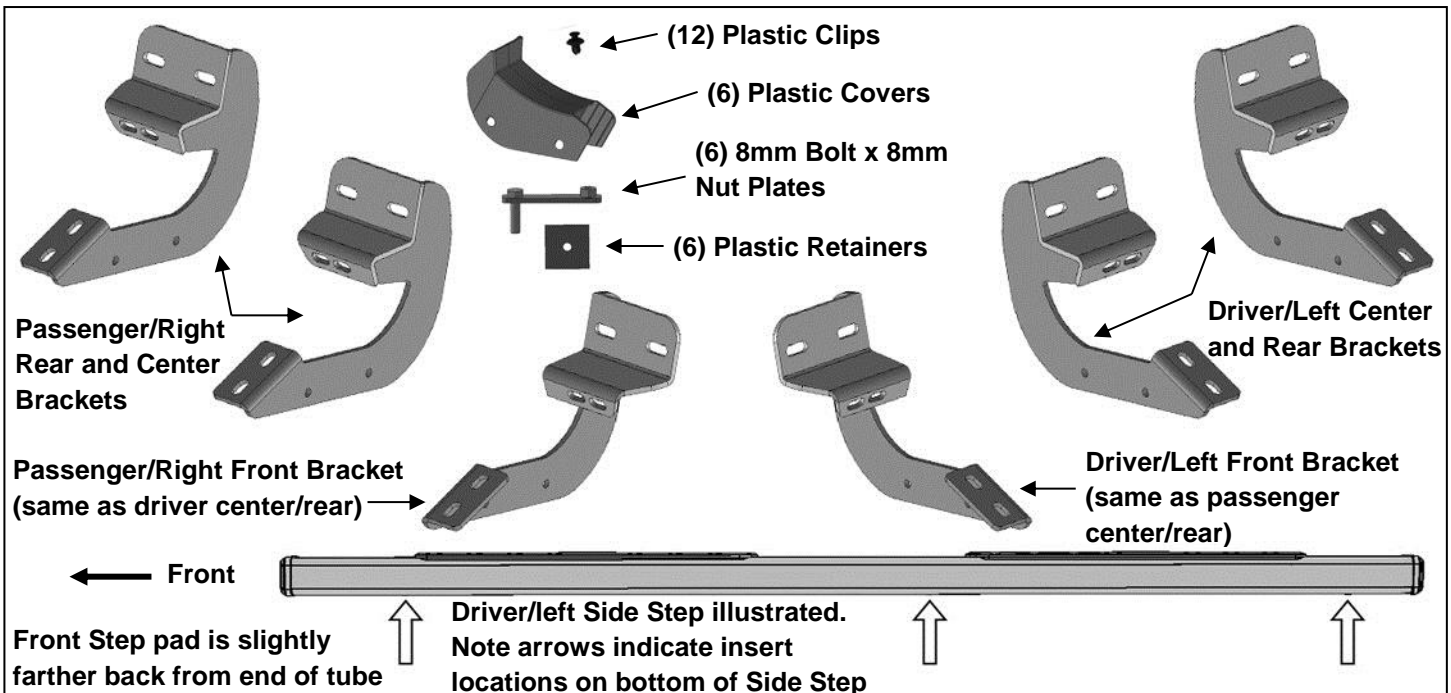

PROCEDURE:

1. REMOVE CONTENTS FROM BOX. VERIFY ALL PARTS ARE PRESENT. READ INSTRUCTIONS CAREFULLY BEFORE STARTING INSTALLATION. DRILLING MAY BE REQUIRED.

2. Starting at the driver side-front of the vehicle, remove the sealing tape covering the factory holes in the side of the inner panel, (Figure 1).

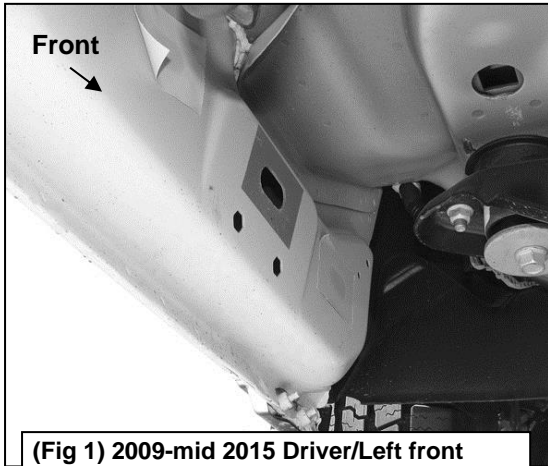

(Fig 1) 2009-mid 2015 Driver/Left front mounting location (No factory holes in pinch weld 2009-2011 models)

3. Determine the correct procedure to attach the driver side front Bracket for your model/year:

Models without factory threaded inserts in body panel:

- Select (1) 8mm Bolt/nut Plate, (Figure 2). Partially thread an 8mm Hex Bolt onto the threaded end of the Nut Plate, (Figure 3). Thread the Hex Bolt in until it is flush with the welded nut. Use the Hex Bolt as a handle and insert the Bolt and Nut Plate into the oval hole, (Figure 4). Feed the threaded bolt on the Bolt Plate through one of the hex shaped factory holes.
- Thread (1) 8mm Plastic Retainer onto the threaded end and down tight against the body panel, (Figure 5). **NOTE:** The Plastic Retainer is designed to keep the Bolt/Nut Plate from falling into the body panel and to aid in Bracket installation.

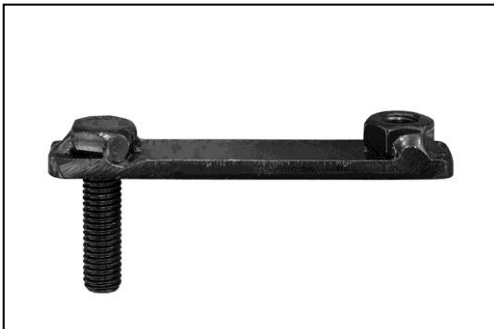

(Fig 2) 8mm Bolt-8mm Nut Plate, **NOTE:** 8mm Bolt-Nut Plate is not required on models with threaded inserts

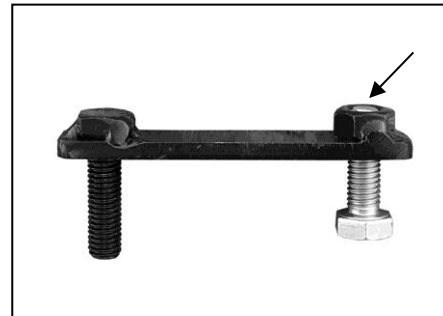

(Fig 3) Thread (1) 8mm Hex Bolt into the nut on the plate. Stop when bolt reaches end of nut as pictured

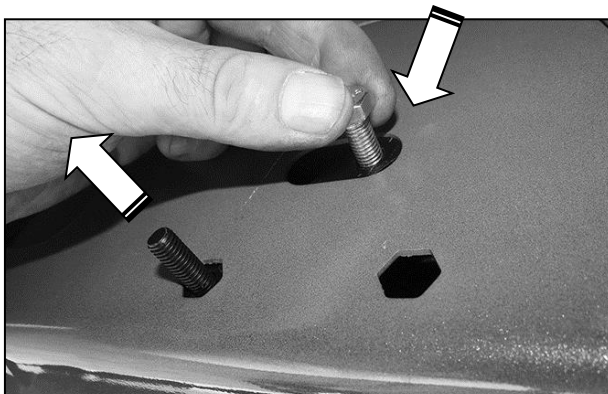

(Fig 4) Use the loose Hex Bolt as a handle. Insert the Bolt Plate into the oval hole and feed the threaded end out either factory hex shaped hole. **IMPORTANT:** Do not let go of the hex bolt until after Plastic Retainer has been threaded onto bolt (Fig 5)

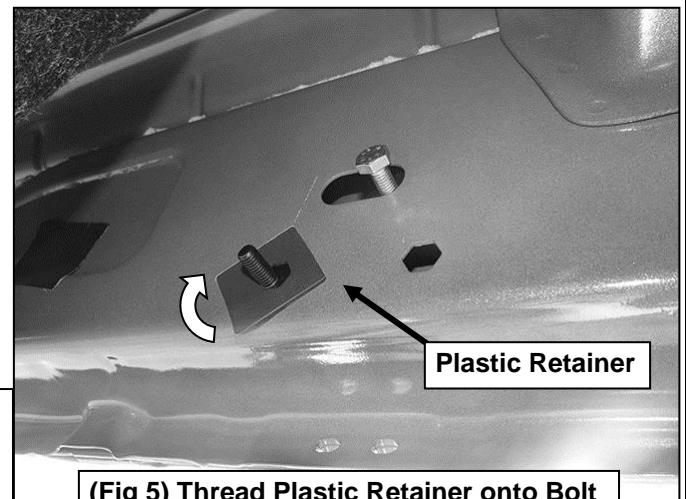

(Fig 5) Thread Plastic Retainer onto Bolt Plate to hold Bolt Plate in position.

- c. Select the driver side front Mounting Bracket, **(Figure 6)**. Attach the Bracket to the threaded end of the Bolt Plate with (1) 8mm Flat Washer, (1) 8mm Lock washer and (1) 8mm Hex Nut, **(Figure 7)**. **IMPORTANT:** Driver/left front Bracket is the same as the passenger/right center and rear Brackets. Do not tighten hardware at this time.
- d. Remove the 8mm Hex Bolt from the nut on the Bolt Plate from **Step 3a**. Rotate the Bolt on the Bolt Plate until the threaded nut lines up with the remaining hole in the Mounting Bracket and body panel, **(Figure 7)**. Attach the Bracket to the threaded Nut Plate with (1) 8mm x 30mm Hex Bolt, (1) 8mm Lock Washer and (1) 8mm Flat Washer, **(Figure 7)**. Do not tighten hardware.

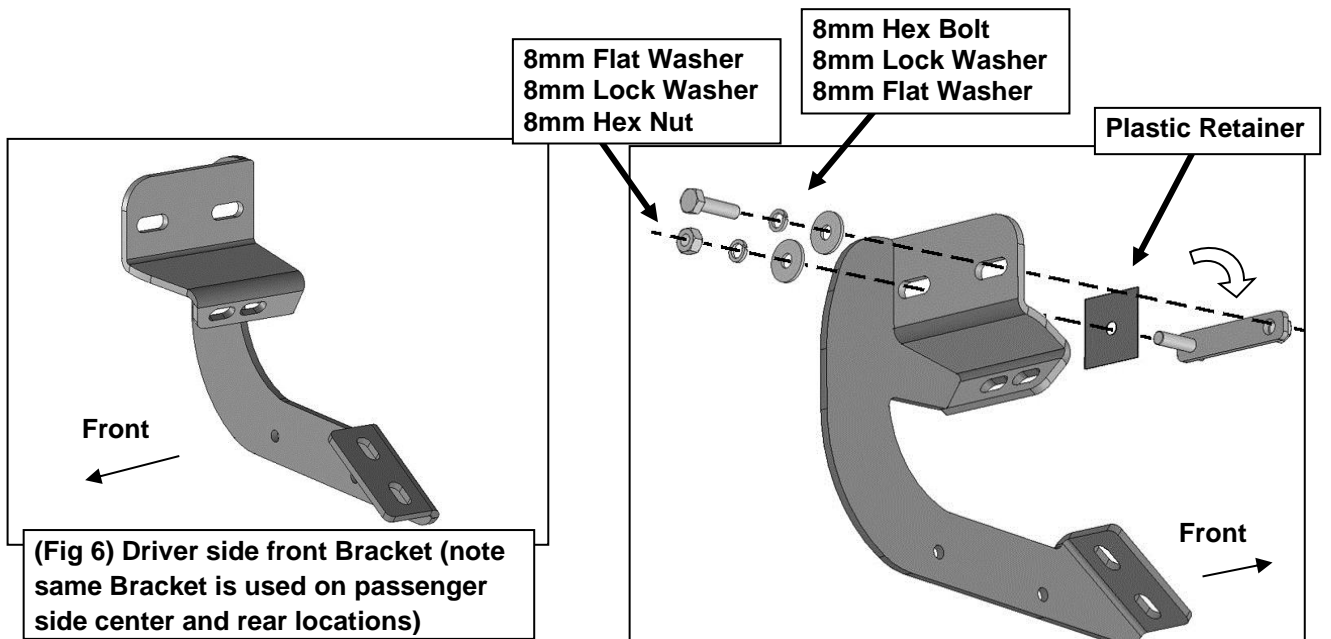

(Fig 6) Driver side front Bracket (note same Bracket is used on passenger side center and rear locations)

(Fig 7) Attach Bracket to threaded end of Bolt Plate first. Remove 8mm Hex Bolt (see Fig 3). Rotate Bolt Plate to line up with remaining factory hex shaped hole.

Models with factory threaded inserts:

- a. Attach the driver side Front Bracket to the threaded inserts with (2) 8mm x 30mm Hex Bolts, (2) 8mm Lock Washers and (2) 8mm Flat Washer, **(Figures 8 & 9)**. Leave hardware loose.

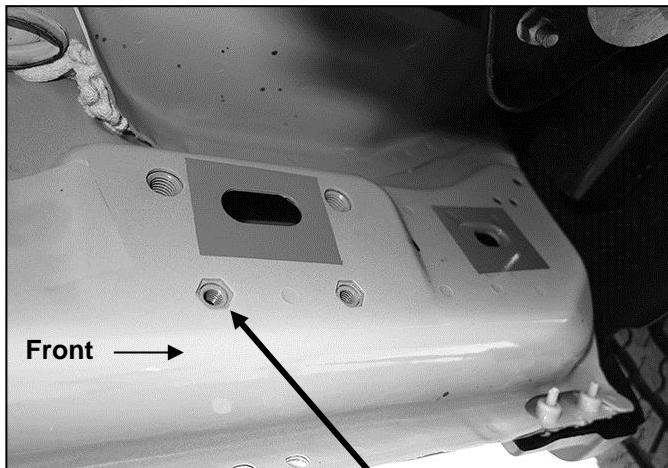

(Fig 8) Driver side front mid 2015-on, an example of models with factory installed threaded inserts

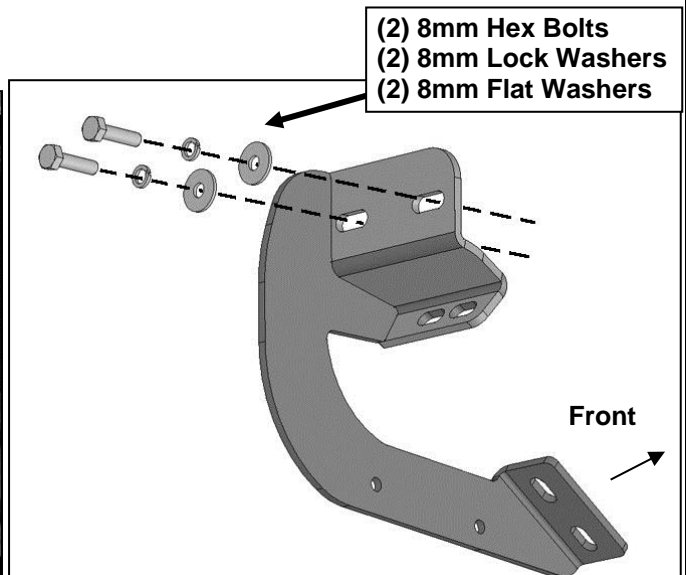

(Fig 9) Driver side front models with factory installed threaded inserts. Bolt Plate not required

4. Next, attach the Bracket to the back of the pinch weld with (2) 6mm x 25mm Socket Head Screws, (4) 6mm Flat Washers and (2) 6mm Flange Nuts, **(Figures 10 & 11)**. Do not fully tighten hardware at this time. **IMPORTANT:** 2009-10 models are not equipped with factory holes and will require drilling through the pinch weld to attach the Support Bracket. Do not drill through pinch weld at this time, (see **Step 8**).

(2) 6mm Screws
(4) 6mm Flat Washers
(2) 6mm Flange Nuts

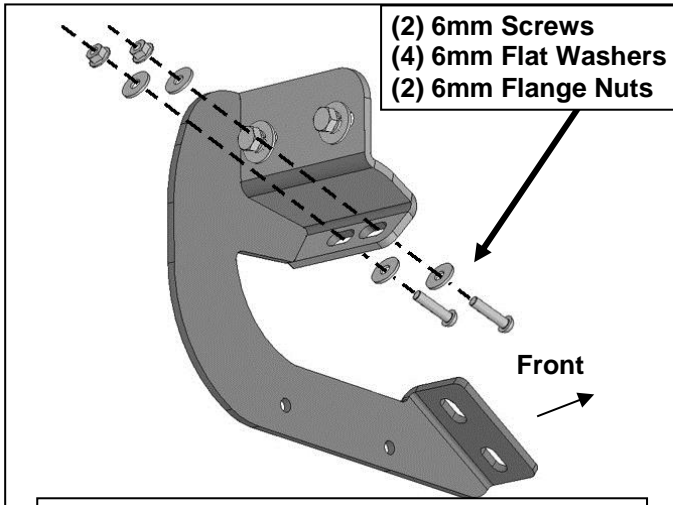

(Fig 10) Attach Bracket to back of pinch weld (models with factory holes in pinch weld only)

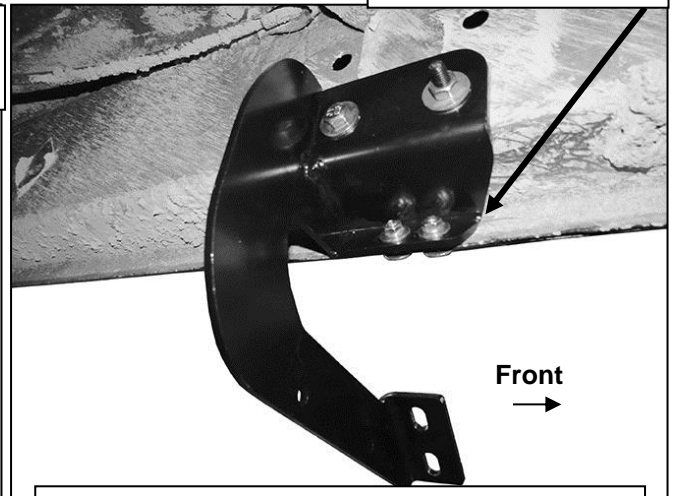

(Fig 11) Attach Bracket to back of pinch weld (models with factory holes in pinch weld only)

5. Select (1) Plastic Bracket Cover and (2) Retaining Clips. Slide the Cover over the driver side front Bracket. Line up the (2) mounting holes in the Cover with the holes in the Bracket. Insert the Clip into the holes and push center pin to expand Clip, **(Figure 12)**. Repeat this Step for all Cover installation.

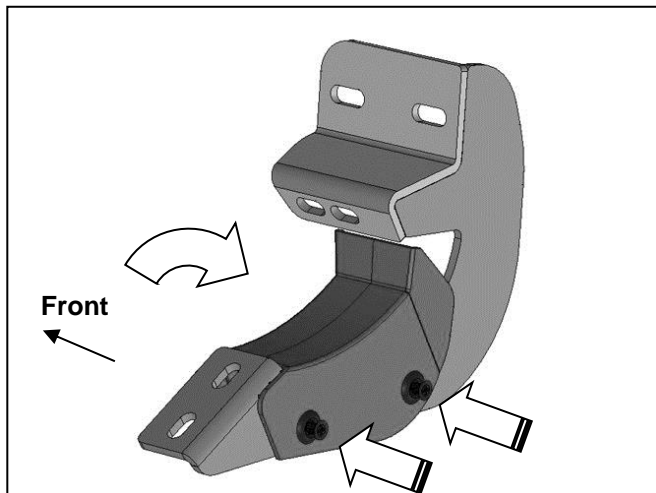

(Fig 12) Slide Cover over top of Bracket. Attach Cover to Bracket with (2) Retaining Clips

6. Move along the side of the body panel to the center mounting location, **(Figure 13)**. Repeat the appropriate **Steps 2—5** to install the driver side center Bracket, **(Figure 14)**. **IMPORTANT:** The front bracket is different from the center and rear Mounting Brackets, (see illustration above-note direction of mounting plate).

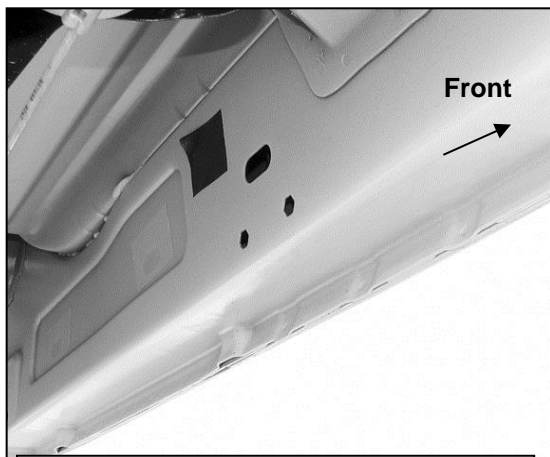

(Fig 13) Driver/Left center location

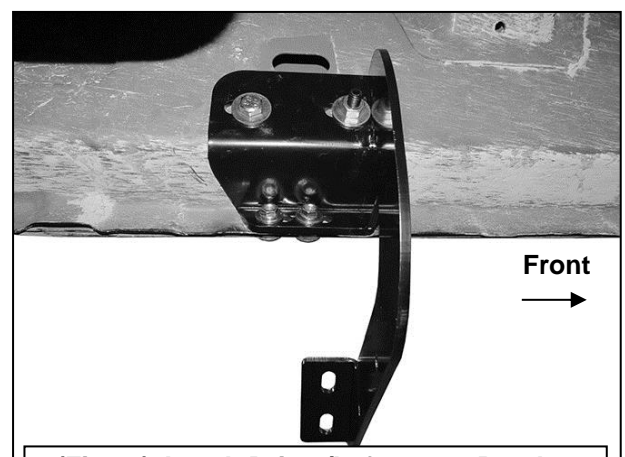

(Fig 14) Attach Driver/Left center Bracket

7. Move to the rear location, (Figure 15). Repeat Step 6 to install the rear Mounting Bracket, (Figure 16).

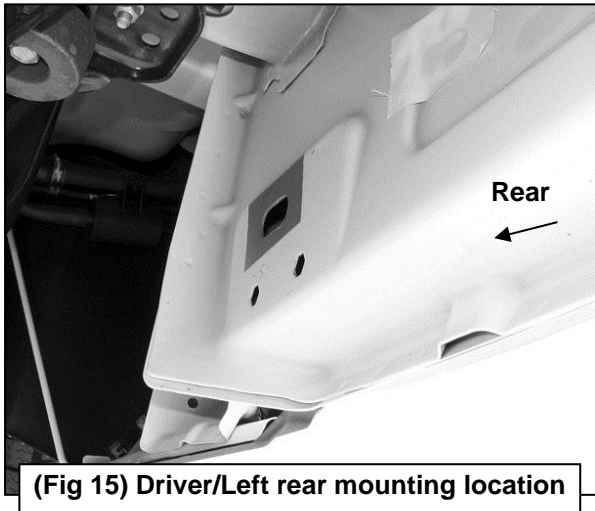

(Fig 15) Driver/Left rear mounting location

IMPORTANT: 2009-2010 models without holes in pinch weld will require drilling 1/4" holes through pinch weld to attach driver side front support bracket. Do complete installation of sidebars first, level sidebar before drilling holes for support bracket.

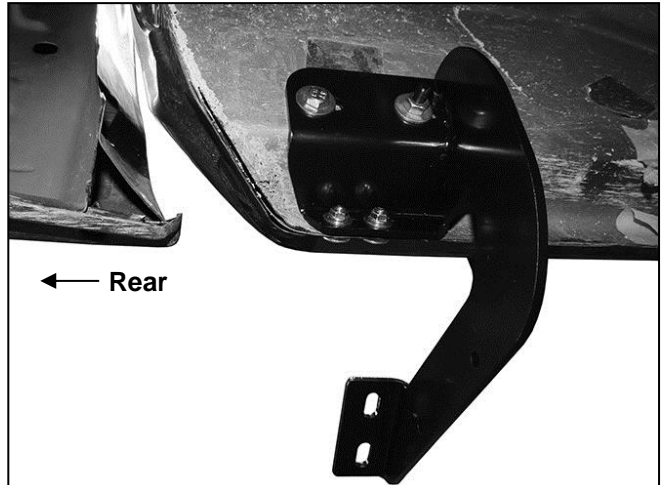

(Fig 16) Driver/Left rear Mounting Bracket assembly

8. Select the driver/left Sidebar. Carefully position the Driver Sidebar onto the (3) Mounting Brackets. **IMPORTANT:** Do not slide, (front to back or rotate), the Sidebar on the Brackets or damage to the finish on the Sidebar may result. Attach the Side Step to the (3) Brackets with (6) 8mm Combination Hex Bolts, (Figures 17—19). Do not fully tighten at this time.

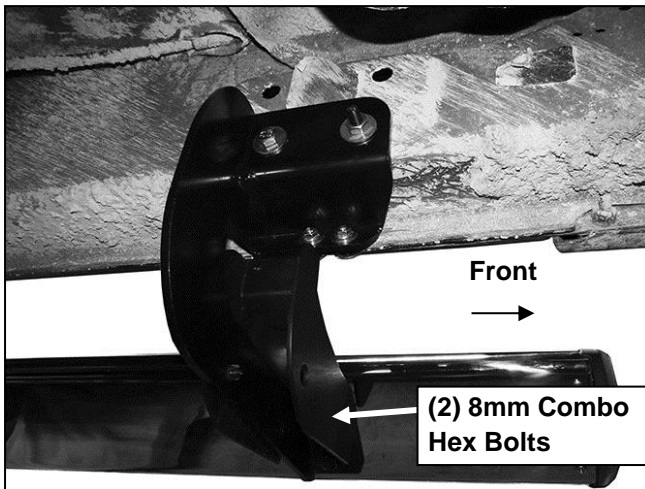

(Fig 17) Driver/Left front Mounting Brackets

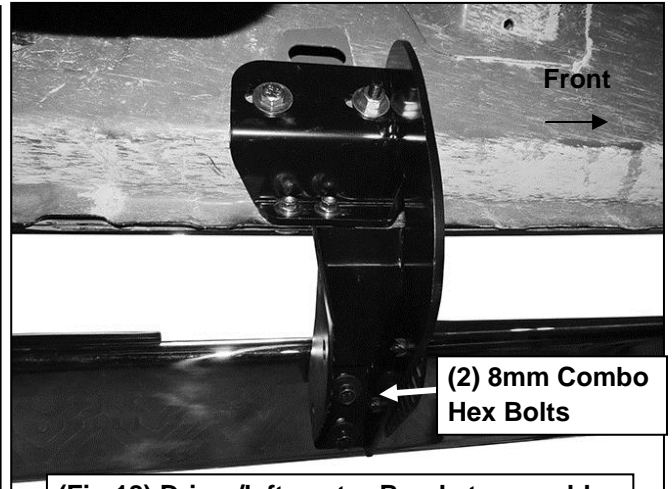

(Fig 18) Driver/left center Bracket assembly

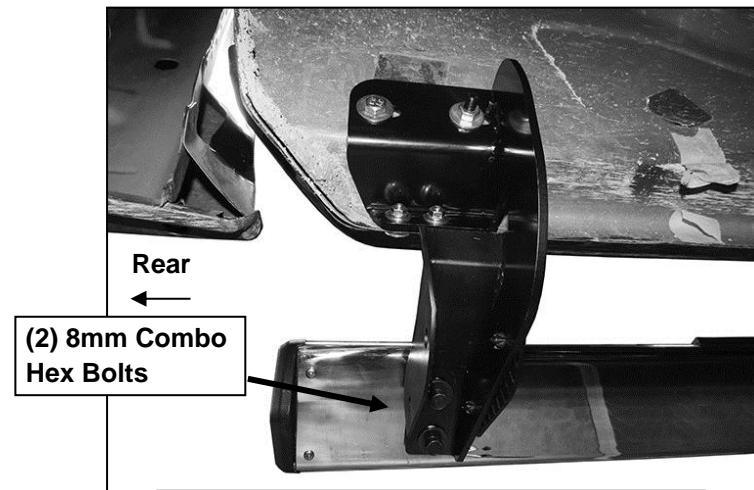

(Fig 19) Driver/left rear Bracket assembly

IMPORTANT: 2009-2010 models without holes in pinch weld will require drilling 1/4" holes through pinch weld to attach driver side front support bracket. Do complete installation of sidebars first, level sidebar before drilling holes for support bracket.

9. Properly level and adjust the Sidebar and fully tighten all hardware.

2009-10 models requiring drilling for driver side Support Brackets:

- a. Level the Side Step to the vehicle. Make sure all (3) Brackets are tight against the bottom of the body panel and tighten all mounting hardware.
 - b. Mark the location of the slots onto the pinch weld.
 - c. Drill (2) 1/4" holes through the pinch weld for each Support Bracket. **IMPORTANT:** Do not drill too close to the bottom edge of the pinch weld. Drill the holes in the center of the marked slots.
 - d. Repeat **Step 4** to attach the Brackets to the drilled holes in the pinch weld. Check for level then fully tighten all hardware.
10. Move to the passenger side of the vehicle. Remove tape covering front, center and rear locations. Repeat **Steps 2—9** for passenger side Mounting Bracket installation. **NOTE:** Refer to the illustration on **Page 1** to identify the correct Mounting Bracket for each of the remaining locations.
11. Do periodic inspections to the installation to make sure that all hardware is secure and tight.

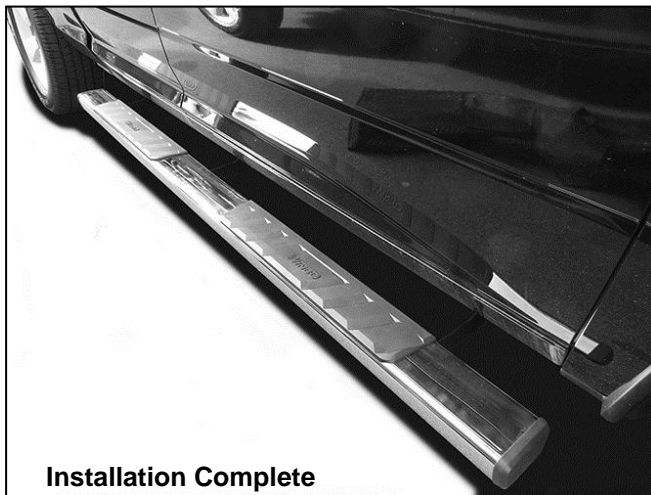

PARTS IDENTIFICATION GUIDE

Driver Side tube packed using "Green" color foam sheet. Passenger Side tube packed using "White" color foam sheet

No.	Parts Identification
1	Passenger / Right 'Rear' Bracket marked "PR"
2	Driver / Left 'Rear' Bracket marked "DR"
3	Passenger / Right 'Center' Bracket marked "PC"
4	Driver / Left 'Center' Bracket marked "DC"
5	Passenger / Right 'Front' Bracket marked "PF"
6	Driver / Left 'Front' Bracket marked "DF"

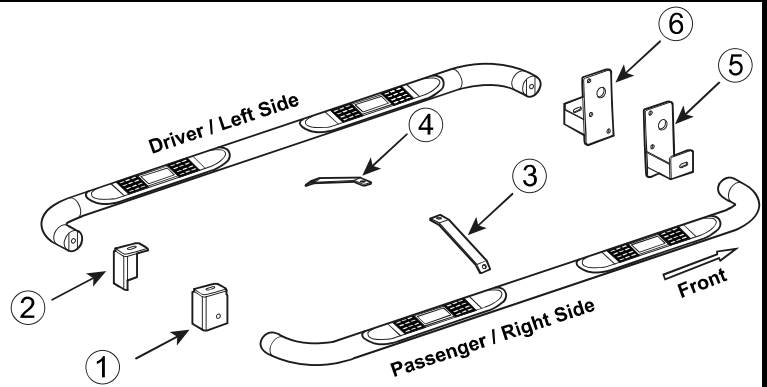

Note:

- This guide is to identify the parts and not a reference for part count.
- For part count, refer Parts List.
- Product / Bracket image is representative and actual design may vary.

PRODUCT CARE

- Periodically check the product to ensure all fasteners are tight and components are intact.
- Regular waxing is recommended to protect the finish of the product.
- **Use ONLY Non-Abrasive automotive wax.** Use of any soap, polish or wax that contains an abrasive is detrimental and can scratch the finish leading to corrosion.
- Aluminum polish may be used to polish small scratches and scuffs for **Stainless Steel finish.**
- Mild soap may be used to clean the product for both **Stainless Steel and Black finish.**

FAQ's

1. Hardware's are not of correct size.

In GMC / Chevrolet truck model 2006 & up, customer needs to reuse the factory body bolts to install the bracket. If your vehicle is not GMC / Chevrolet 2006 & up, ensure that holes are not partially covered with any plastic grommet or rust? If it is, remove the plastic grommet & rust from the thread holes & re-try the installation.

2. Mounting Bracket are not getting Installed properly.

In some cases Illustration images shown in Installation manual may not be the exactly same as per actual vehicle images ,also if Driver / Passenger side mounting brackets are very identical in the design, suggest referring Parts Identification guide to avoid fitment issue.

3. Products are thumping / rattling after installation.

Ensure that all required mounting brackets / hardware's are installed & tighten correctly. Suggest using white lithium / regular grease between the metal to metal contact surfaces.

4. Side Bar is not aligning with vehicle / Step Pads are not aligning with vehicle doors.

Side bar may be interchanged or mounting brackets are not installed at the correct position in the vehicle. Refer Parts identification guide.

5. Missing / Excess Hardware.

Recheck hardware count as per the part list.

6. Product not installing properly.

Ensure make model year, cab length and bed size of your vehicle is listed in the application. All installation steps are followed correctly.

Check out these other TrailFX Products!!



BULL BAR



GRILLE GUARDS



BED RAILS



RUNNING BOARDS

Keystone Automotive Operations Inc. (KAO) warrants this product to be free of defects in material and workmanship at the time of purchase by the original retail consumer. KAO disclaims any other warranties, express or implied, including the warranty of fitness for a particular purpose or an intended use. If the product is found to be defective, KAO may replace or repair the product at our option, when the product is returned prepaid, with proof of purchase. Alteration to, improper installation, or misuse of this product voids the warranty. KAO's liability is limited to repair or replacement of products found to be defective, and specifically excludes liability for any incidental or consequential loss or damage.