

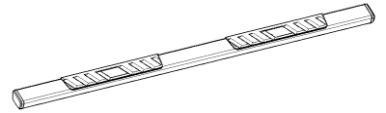

4" Side Bar

Part No. A4008S/B



Fits: **2007- Current** **Toyota Tundra Crew Max**



REMOVE CONTENTS FROM BOX. VERIFY ALL PARTS ARE PRESENT.



READ INSTRUCTIONS CAREFULLY BEFORE STARTING INSTALLATION.

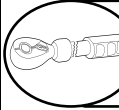

DO NOT OVER TORQUE. STANDARD OPERATING LOAD FOR TIGHTEN BODY MOUNT NUTS & BOLTS VARIES FROM **45** TO **65** FOOT POUND.



60-180 min

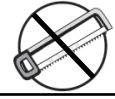

Cutting Not Required



Drilling Not Required

PARTS LIST:

Qty	Part Description	Qty	Part Description
1	Driver/left Side Step	1	Passenger/Right Rear Mounting Bracket
1	Passenger/right Side Step	12	8-1.25mm x 30mm Hex Bolts
1	Driver/Left Front Mounting Bracket	12	8mm x 24mm OD x 2mm Flat Washers
1	Passenger/Right Front Mounting Bracket	12	8mm Lock Washers
1	Driver/Left Center Mounting Bracket	12	8-1.25mm x 25mm Combination Bolts
1	Passenger/Right Center Mounting Bracket	12	Plastic Clips
1	Driver/Left Rear Mounting Bracket	6	Plastic Covers

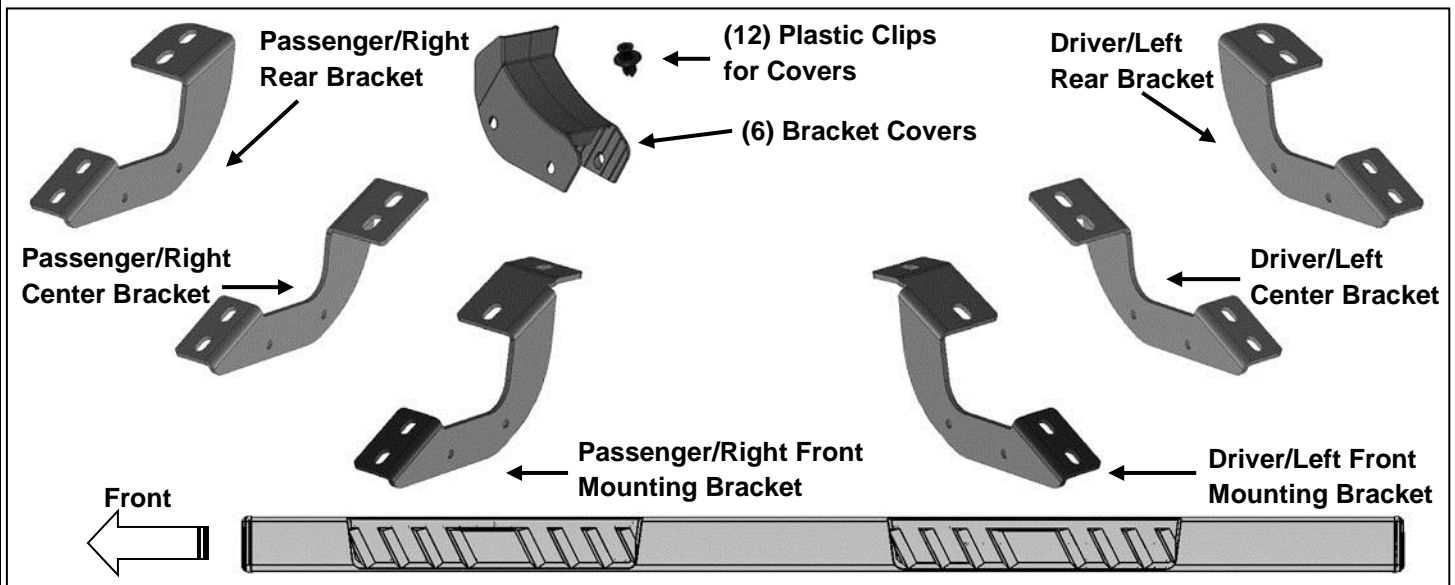

INSTALLATION PROCEDURE:

1. Starting on the passenger side front of the vehicle, remove the plastic plugs or bolts covering the threaded holes in the body panel, (**Figure 1**). Select the passenger side front Mounting Bracket, (**Figure 2**). Attach the Bracket to the vehicle using the included (2) 8mm x 30mm Hex Bolts, (2) 8mm Lock Washers and (2) 8mm Flat Washers, (**Figure 3**). Do not tighten hardware at this time.
2. Select (1) Plastic Bracket Cover and (2) Retaining Clips, (**Figure 4**). Slide the Cover over the front Bracket. Line up the mounting holes in the Cover with the holes in the Bracket. Insert (1) Clip into each hole and push center pin to expand Clip. Repeat this Step for all Cover installations.

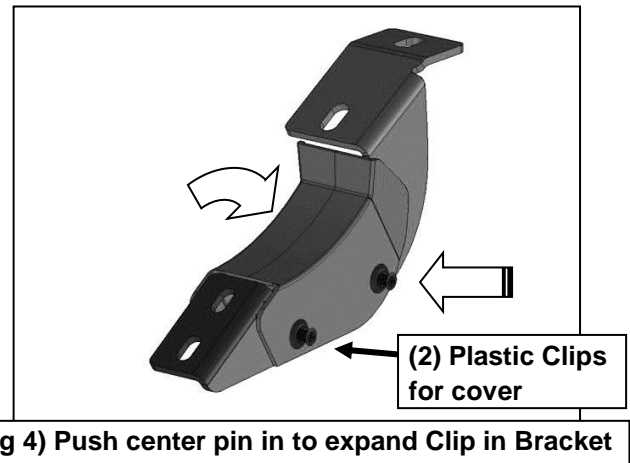
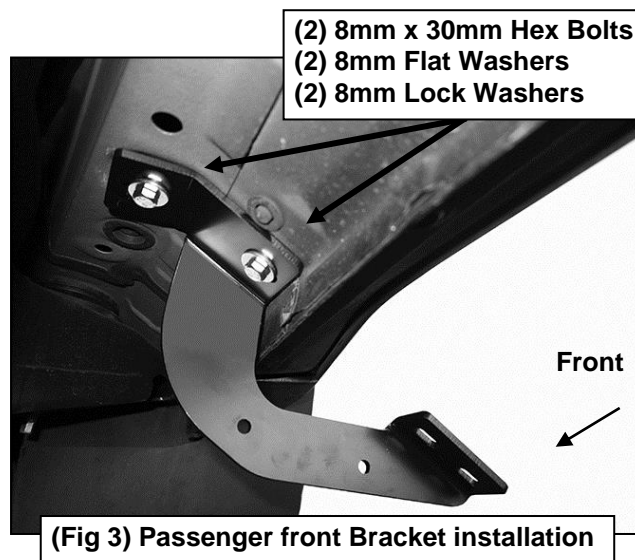
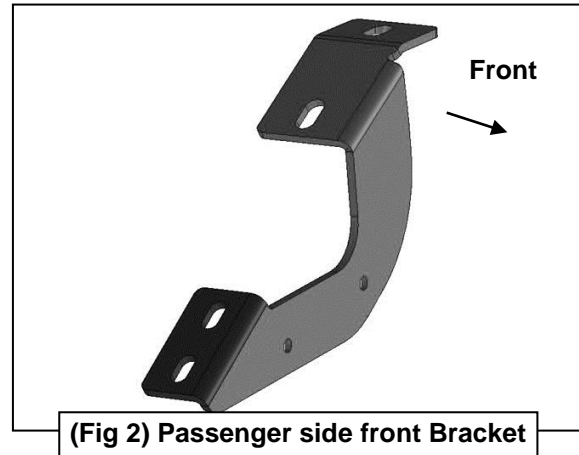
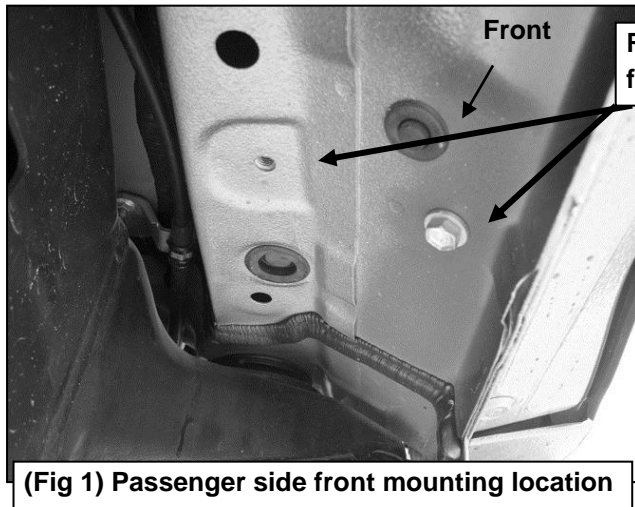

3. Move to the 2nd mounting location, (**Figure 5**). Repeat **Steps 2 & 3** for center Bracket installation, (**Figures 6—8**). **IMPORTANT:** There are (4) mounting locations along the side of the vehicle. Installation will use the 1st, 2nd and 4th mounting locations only.

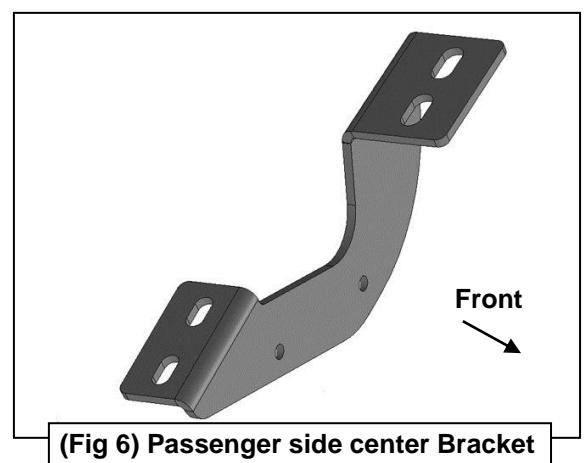
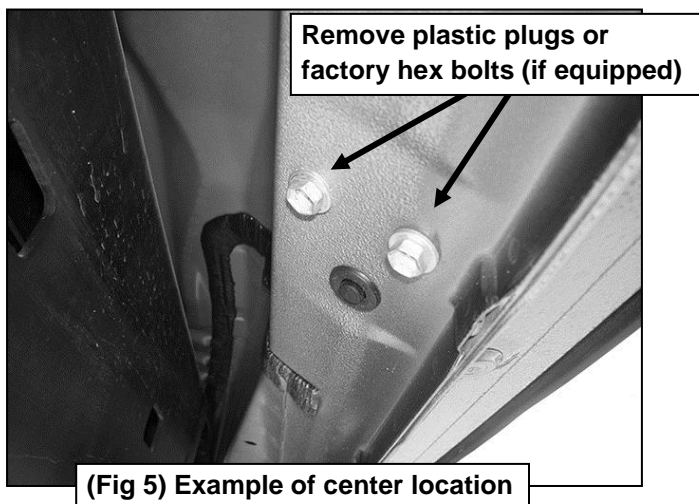

- (2) 8mm x 30mm Hex Bolts
- (2) 8mm Flat Washers
- (2) 8mm Lock Washers



(Fig 7) Passenger side center Bracket installation



(Fig 8) Passenger side center Bracket with cover

4. Continue along the body to the last mounting location at the rear of the cab, (Figure 9). Repeat Steps 2 & 3 for rear Mounting Bracket installation, (Figures 9—11).

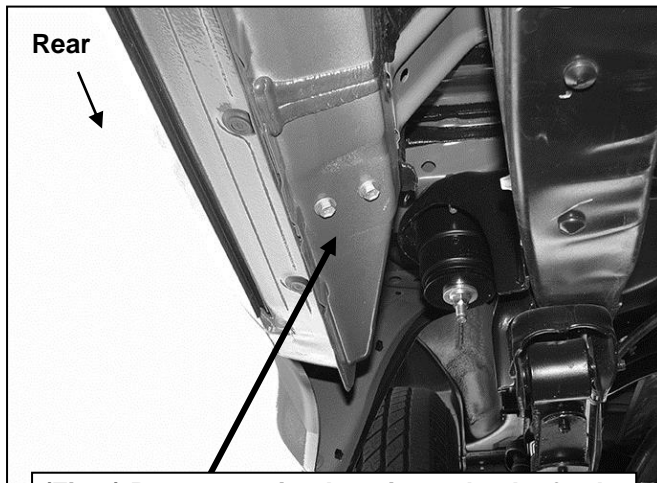

(Fig 9) Rear mounting location at back of cab

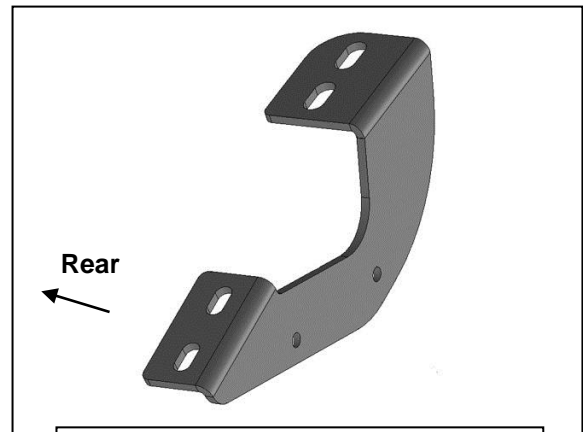

(Fig 10) Passenger side rear Bracket

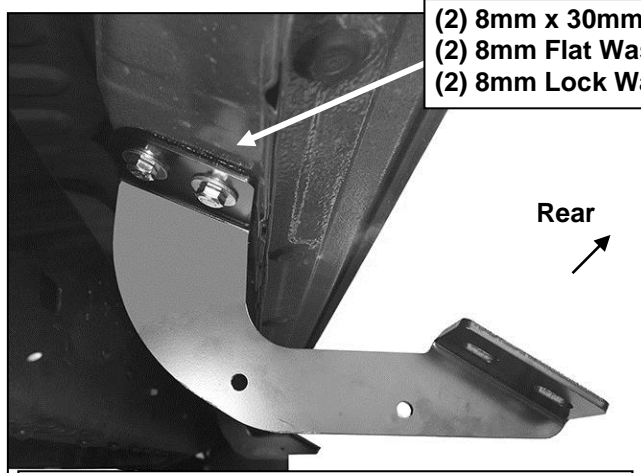

(Fig 11) Passenger side rear Bracket installed

- (2) 8mm x 30mm Hex Bolts
- (2) 8mm Flat Washers
- (2) 8mm Lock Washers

5. Select the passenger/right Side Step. Carefully position the Side Step onto the (3) Mounting Brackets. **IMPORTANT:** Do not slide the Side Step on the Brackets or damage to the finish may result. Attach the Side Step to the Mounting Brackets with (6) 8mm x 25mm Combination Hex Bolts, (Figures 12—14). Do not tighten hardware.
6. Level and adjust the Side Step and fully tighten all hardware.
7. Repeat Steps 2—7 for driver Side Step installation.
8. Do periodic inspections to the installation to make sure that all hardware is secure and tight.

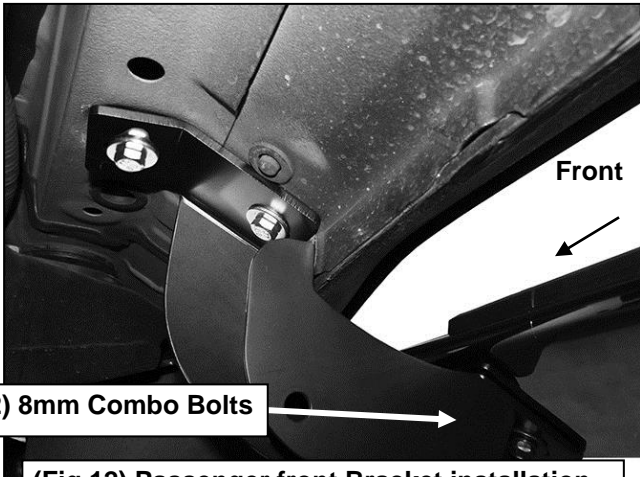

(2) 8mm Combo Bolts

(Fig 12) Passenger front Bracket installation



(2) 8mm Combo Bolts

(Fig 13) Passenger center Bracket installation

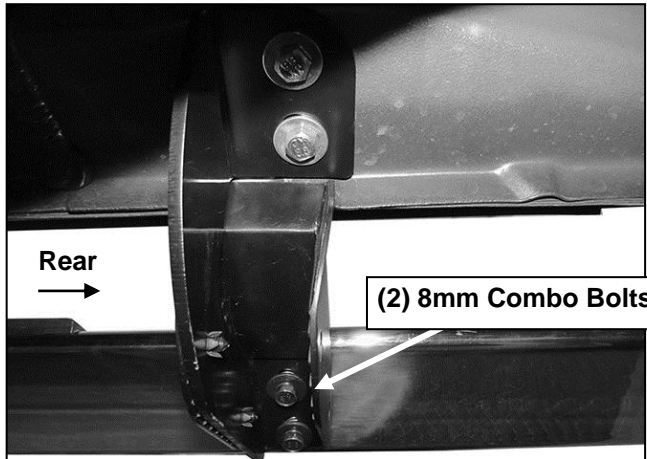

(2) 8mm Combo Bolts

(Fig 14) Passenger rear Bracket installation

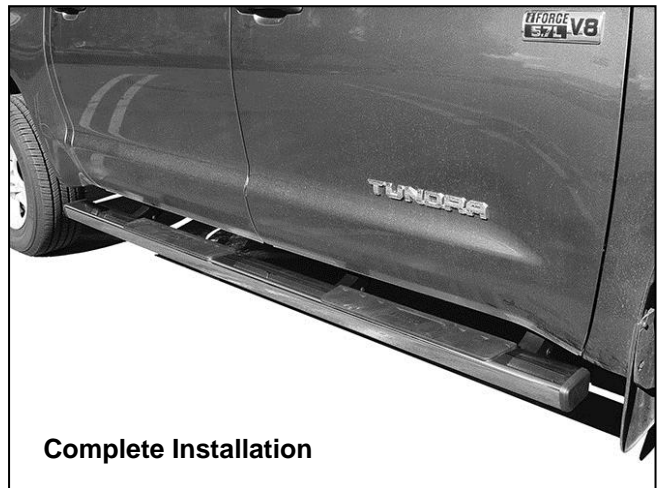

Complete Installation

PARTS IDENTIFICATION GUIDE

Driver Side tube packed using "Green" color foam sheet. Passenger Side tube packed using "White" color foam sheet

No.	Parts Identification
1	Passenger / Right 'Rear' Bracket marked "PR"
2	Driver / Left 'Rear' Bracket marked "DR"
3	Passenger / Right 'Center' Bracket marked "PC"
4	Driver / Left 'Center' Bracket marked "DC"
5	Passenger / Right 'Front' Bracket marked "PF"
6	Driver / Left 'Front' Bracket marked "DF"

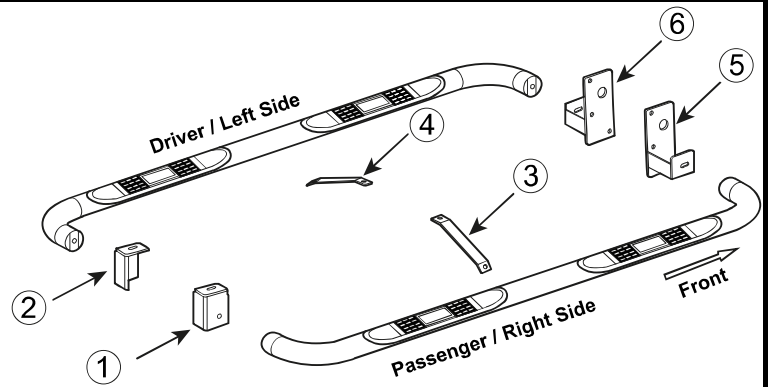

Note:

- This guide is to identify the parts and not a reference for part count.
- For part count, refer Parts List.
- Product / Bracket image is representative and actual design may vary.

PRODUCT CARE

- Periodically check the product to ensure all fasteners are tight and components are intact.
- Regular waxing is recommended to protect the finish of the product.
- **Use ONLY Non-Abrasive automotive wax.** Use of any soap, polish or wax that contains an abrasive is detrimental and can scratch the finish leading to corrosion.
- Aluminum polish may be used to polish small scratches and scuffs for **Stainless Steel finish.**
- Mild soap may be used to clean the product for both **Stainless Steel and Black finish.**

FAQ's

1. Hardware's are not of correct size.

In GMC / Chevrolet truck model 2006 & up, customer needs to reuse the factory body bolts to install the bracket. If your vehicle is not GMC / Chevrolet 2006 & up, ensure that holes are not partially covered with any plastic grommet or rust? If it is, remove the plastic grommet & rust from the thread holes & re-try the installation.

2. Mounting Bracket are not getting Installed properly.

In some cases Illustration images shown in Installation manual may not be the exactly same as per actual vehicle images ,also if Driver / Passenger side mounting brackets are very identical in the design, suggest referring Parts Identification guide to avoid fitment issue.

3. Products are thumping / rattling after installation.

Ensure that all required mounting brackets / hardware's are installed & tighten correctly. Suggest using white lithium / regular grease between the metal to metal contact surfaces.

4. Side Bar is not aligning with vehicle / Step Pads are not aligning with vehicle doors.

Side bar may be interchanged or mounting brackets are not installed at the correct position in the vehicle. Refer Parts identification guide.

5. Missing / Excess Hardware.

Recheck hardware count as per the part list.

6. Product not installing properly.

Ensure make model year, cab length and bed size of your vehicle is listed in the application. All installation steps are followed correctly.

Check out these other TrailFX Products!!



BULL BAR



GRILLE GUARDS



BED RAILS



RUNNING BOARDS

Keystone Automotive Operations Inc. (KAO) warrants this product to be free of defects in material and workmanship at the time of purchase by the original retail consumer. KAO disclaims any other warranties, express or implied, including the warranty of fitness for a particular purpose or an intended use. If the product is found to be defective, KAO may replace or repair the product at our option, when the product is returned prepaid, with proof of purchase. Alteration to, improper installation, or misuse of this product voids the warranty. KAO's liability is limited to repair or replacement of products found to be defective, and specifically excludes liability for any incidental or consequential loss or damage.