

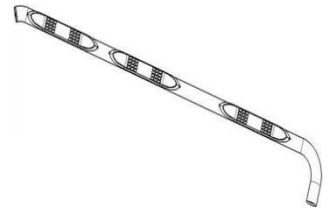

3" W2W Nerf Bar

Part No. A3004S/B



Fits: 2012 - Current Chevrolet Silverado/ GMC Sierra crew cab 2500HD/3500 8' bed



Excludes Vehicle with dual rear wheels.



60-180 min

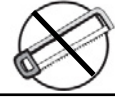

Cutting Not Required



Drilling Not Required



REMOVE CONTENTS FROM BOX. VERIFY ALL PARTS ARE PRESENT.



READ INSTRUCTIONS CAREFULLY BEFORE STARTING INSTALLATION.

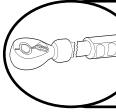

DO NOT OVER TORQUE. STANDARD OPERATING LOAD FOR TIGHTEN BODY MOUNT NUTS & BOLTS VARIES FROM 45 TO 65 FOOT POUND.

PARTS LIST:

Qty	Part Description	Qty	Part Description
1	Driver/Left Sidebar	2	12mm Plastic Retainers
1	Passenger/Right Sidebar	2	10mm Plastic Retainers
1	Driver/Left Front Mounting Bracket	2	1/2" x 2" Hex Bolts
1	Passenger/Right Front Mounting Bracket	2	1/2" x 1-1/4" OD x 3/32 Flat Washers
1	Driver/Left Center Mounting Bracket	2	1/2" Lock Washers
1	Passenger/Right Center Mounting Bracket	2	12mm x 32mm OD x 3mm flat washers
1	Driver/Left Rear Cab Mounting Bracket	2	12mm Lock Washers
1	Passenger/Right Rear Cab Mounting Bracket	2	12mm Hex Nuts
1	Driver/Left Rear Cab Support Bracket	8	10-1.50mm x 30mm Hex Bolts
1	Passenger/Right Rear Cab Support Bracket	18	10mm x 20mm OD x 2mm Flat Washers
1	Driver/Left Bed Rear Bed Mounting Bracket	10	10mm Lock Washers
1	Passenger/Right Rear Bed Mounting Bracket	10	10mm Hex Nuts
1	Driver/Left Rear Tube Bracket	14	8-1.25mm x 25mm Hex Bolts
1	Passenger/Right Rear Tube Bracket	2	8mm x 28mm OD x 3mm Large Flat Washers
1	Driver/Left Bed Rear Bed Support Bracket	12	8mm x 22mm OD x 1.5mm Flat Washers
1	Passenger/Right Rear Bed Support Bracket	14	8mm Lock Washers
2	12mm Bolt Plates	2	10mm Button Head Bolt Plates

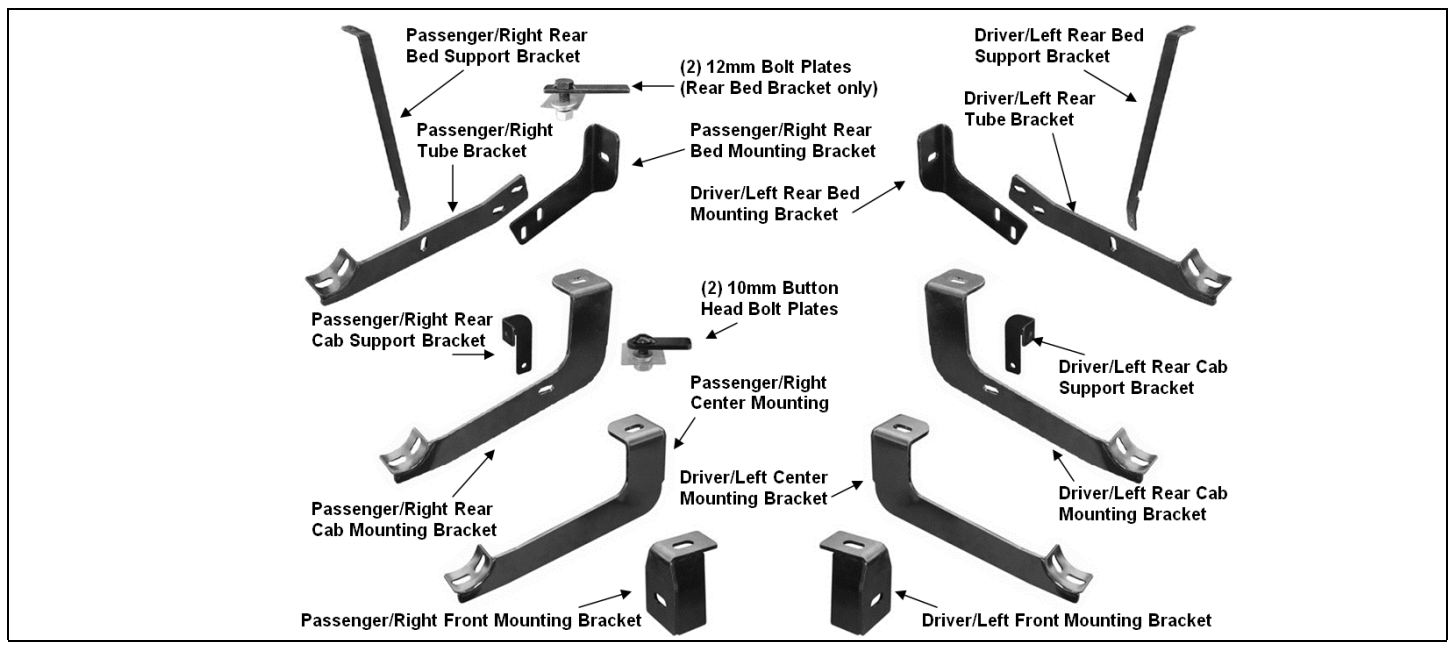

IMPORTANT ALERT: GM uses a very strong thread-locking compound on all body bolts. Use of an air assisted impact ratchet can cause damage to the threads on factory body mount bolts and the internal nut assembly because of this thread locking compound. We only recommend the use of hand tools to slowly remove and reinstall body mount bolts on all GM vehicles.

PROCEDURE:

CRITICAL INFORMATION: If during the removal process, it becomes increasingly difficult to unscrew the body mount bolt with hand tools, tighten the bolt several rotations to clear the thread locking compound from the threads, then reverse direction and continue to unscrew until the body mount bolt is out. Repeat this process as necessary on all GM body mount bolts. Use of an appropriate anti-seize compound is highly recommended for re-installation. Tighten body mount bolt to factory torque specifications for your particular model year.

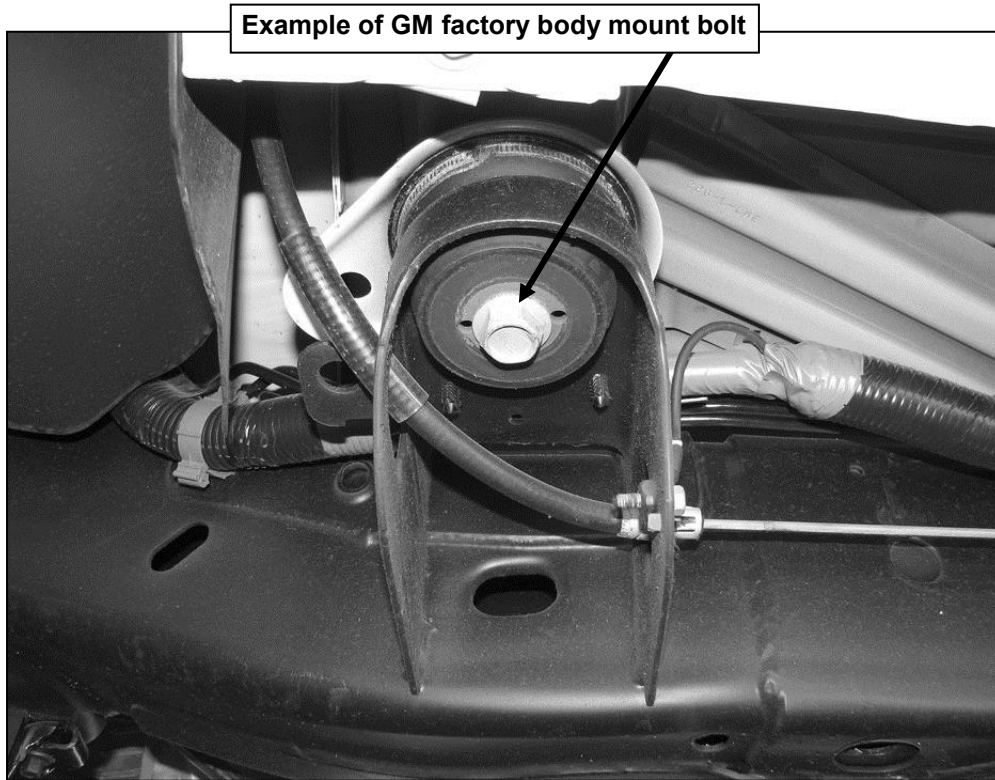

INSTALLATION PROCEDURE

1. Start installation from under the driver side of the vehicle. Remove the driver side front body mount bolt, steel washer, (if equipped), and rubber bushing, (**Figure 1**).

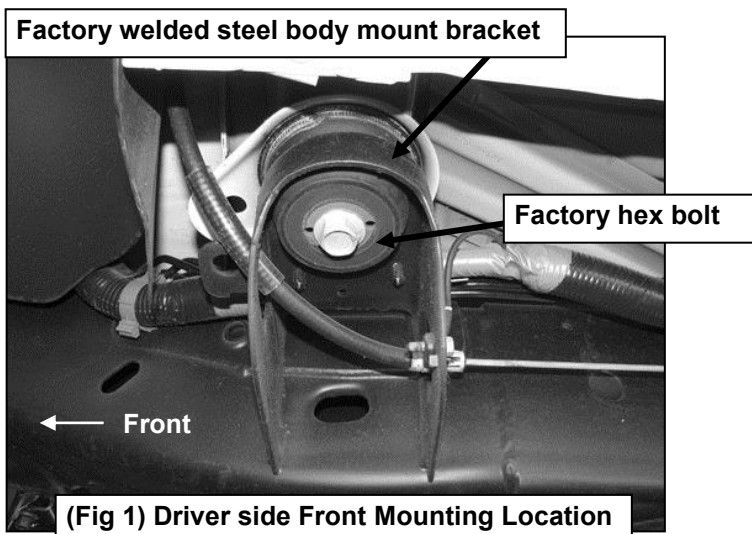

2. Select the driver side front Mounting Bracket. Insert the factory body mount bolt through the Mounting Bracket and into the steel washer, (if equipped), and rubber bushing. Hang the Mounting Bracket in position by partially threading the factory body mount bolt up into place, (**Figure 2**). Snug but do not tighten hardware at this time.

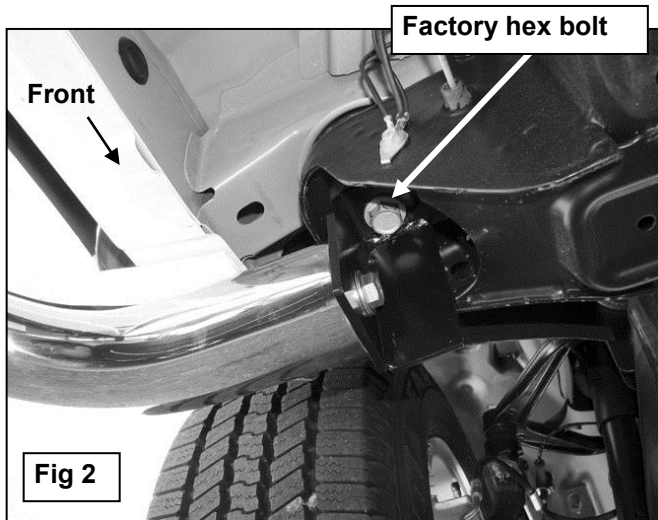

VERY IMPORTANT! There are several different designs, (depending on model year), for the factory body mount frame bracket, (**Figure 1**). If necessary, the Front Mounting Brackets, (applies to front only), can be switched, driver side to passenger side, to provide additional clearance between the gusset on the Mounting Bracket and the factory steel body mount bracket welded to the frame.

To prevent unnecessary noise, adjust the position of all Mounting Brackets so that once tightened, the Mounting Brackets do not come in contact with the factory body mount bracket.

3. Move toward the center of the cab and locate the center body mount bracket. Remove the factory hex bolt as described in **Step 2**. Select the driver side Center Cab Bracket, (**Figure 3**). Bolt the Bracket to the body mount as described in **Step 3**. **NOTE:** Cradle on Bracket will face to rear of vehicle.
- 4.

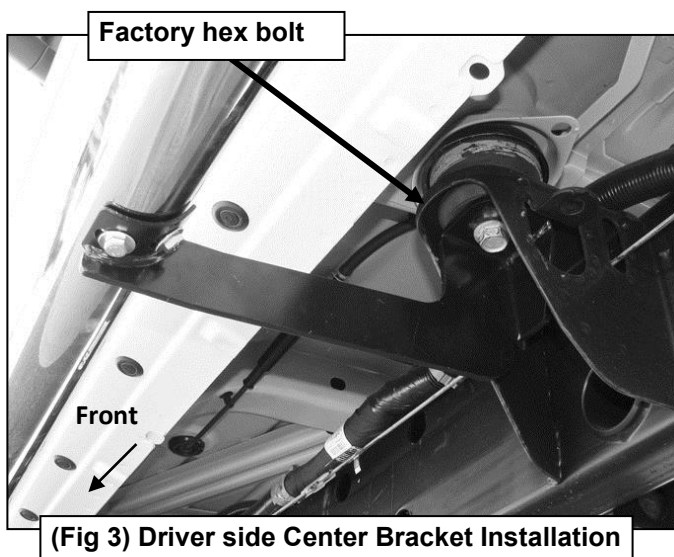

5. Move to the rear cab body mount and repeat **Step 3** to bolt the driver side Rear Cab Mounting Bracket to the rear cab body mount, (**Figure 4**).

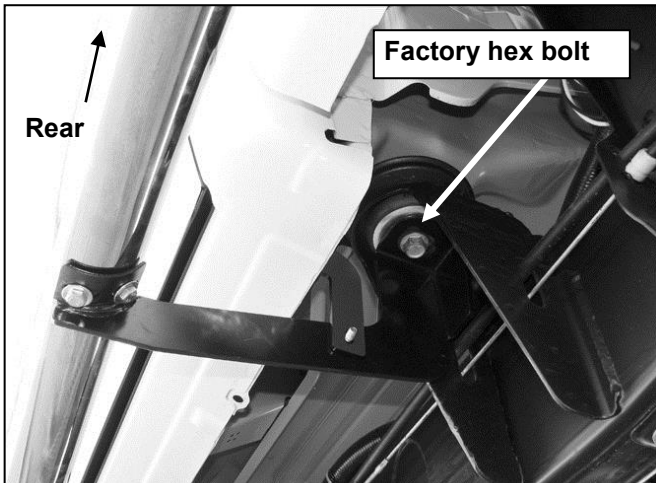

(Fig 4) Driver side Rear Cab Bracket Installation

6. Remove the rubber plug on the inner body panel directly above the previously installed Rear Cab Bracket, (**Figure 5**). Select (1) 10mm Button Head Bolt Plate and (1) 10mm Plastic Retainer, (**Figure 6A**). Insert the Bolt Plate into the hole and thread the Plastic Retainer down until it is tight against the body panel, (**Figure 6B**). **IMPORTANT:** The Plastic Retainer is designed to prevent the Bolt Plate from falling into the body cavity and to aid in installing the Support Bracket.

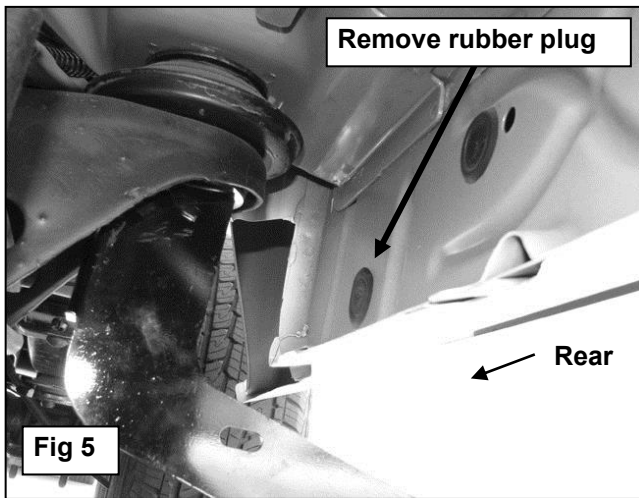

10mm Button Head Bolt Plate
10mm Plastic Retainer

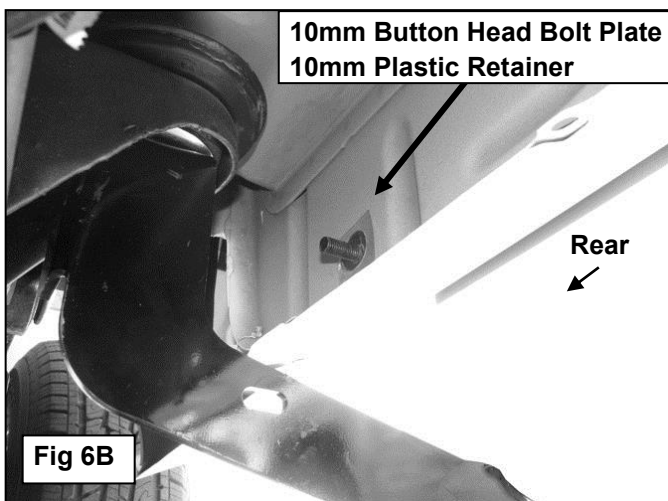
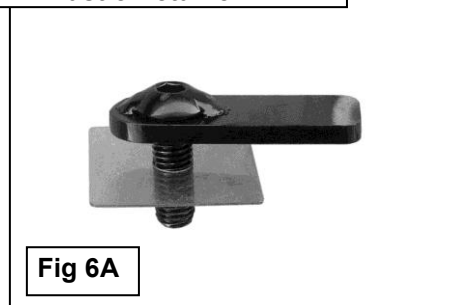

7. Select the driver side Rear Cab Support Bracket, **(Figure 7A)**. Attach the 90-degree bent end of the Support Bracket to the Bolt Plate with (1) 10mm Lock Washer, (1) 10mm Flat Washer and (1) 10mm Hex Nut. Bolt the lower flat end of the Support Bracket to the back of the Rear Cab Bracket with (1) 10mm x 30mm Hex Bolt, (2) 10mm Flat Washers, (1) 10mm Lock Washer and (1) 10mm Hex Nut, **(Figure 7B)**. Do not tighten hardware at this time.

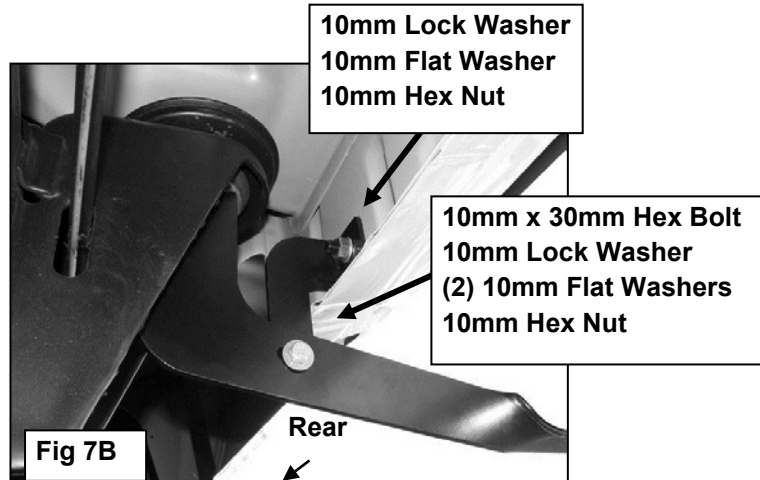

8. Move back along the side of the vehicle to just in front of the rear wheel opening. Locate the oval slot in the side of the frame channel in front of the leaf spring mounting bracket, **(Figure 8)**. Select (1) 12mm Bolt Plate and (1) 12mm Plastic Retainer, **(Figure 9A)**, Insert the Bolt Plate into the slot and thread the Plastic Retainer down until it is tight against the body panel, **(Figure 9B)**. Rotate the Bolt Plate so that the Plate is across the oval opening. Select the driver side Bed Mounting Bracket, **(Figure 10)**. Bolt the Bracket to the Bolt Plate with (1) 12mm Flat Washer, (1) 12mm Lock Washer and (1) 12mm Hex Nut, **(Figure 11)**. Snug but do not fully tighten Hex Nut at this time.

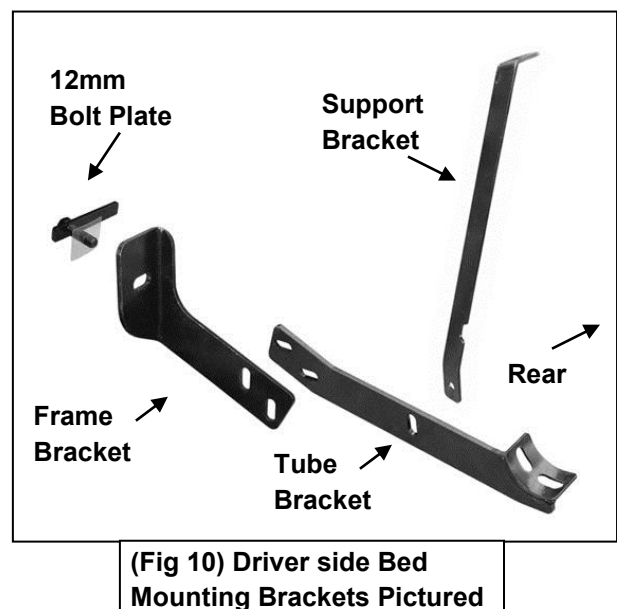
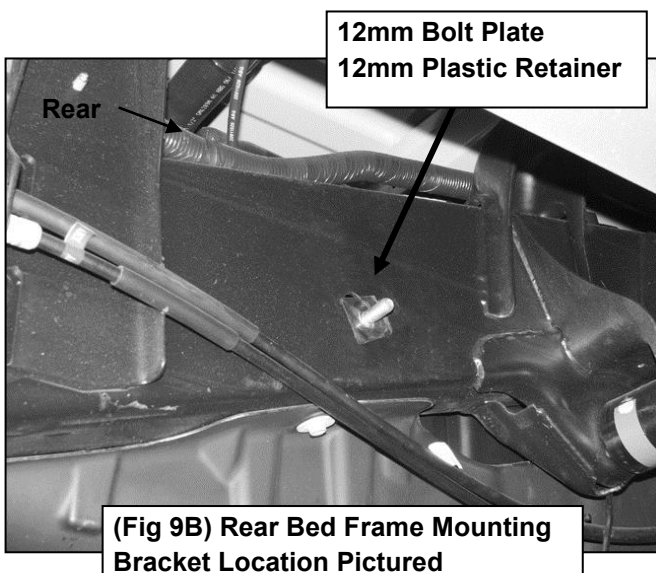
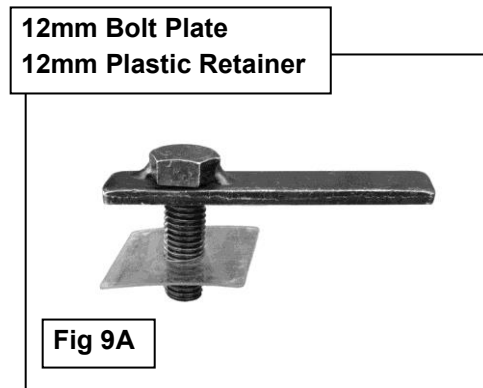
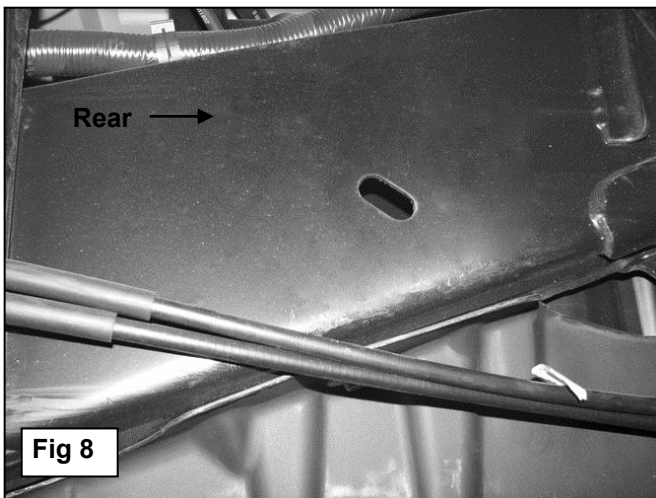

12mm Flat Washer
12mm Lock Washer
12mm Hex Nut

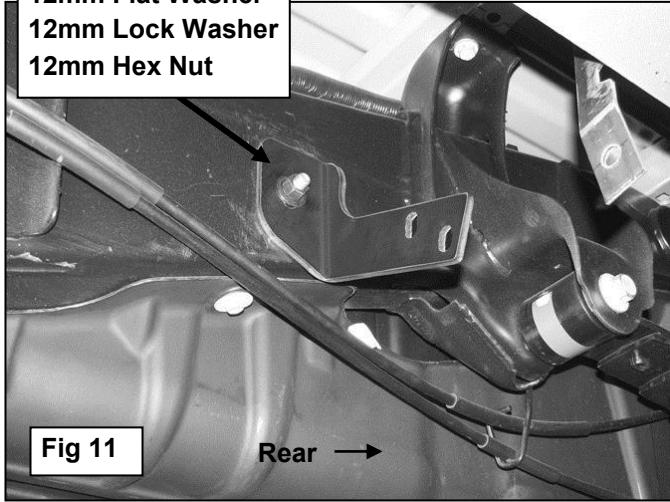

Fig 11

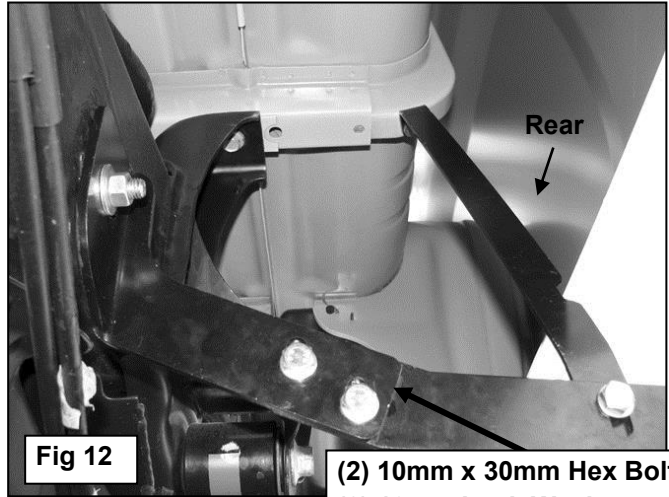
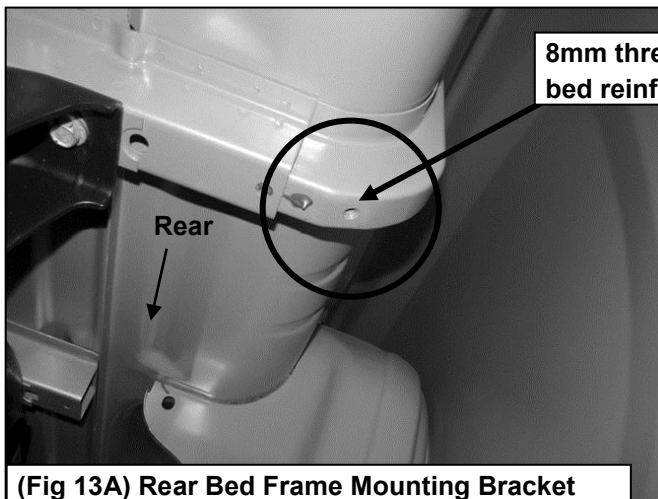

Fig 12

(2) 10mm x 30mm Hex Bolt s
(2) 10mm Lock Washers
(4) 10mm Flat Washers
(2) 10mm Hex Nuts

- Next, select the driver side Rear Tube Bracket, (**Figure 10**). Bolt the Tube Bracket to the back of the Mounting Bracket with (2)10mm x 30mm Hex Bolts, (4) 10mm Flat Washers, (2) 10mm Lock Washers and (2) 10mm Hex Nuts, (**Figure 12**). Leave hardware loose at this time.
- Locate the threaded hole on the bottom of the reinforcement channel welded to the bottom of the bed above the leaf spring mount, (**Figure 13A**). Select the long driver side Bed Support Bracket, (**Figure 10**). Bolt the 90-degree bent end of the Bracket to the threaded hole with (1) 8mm Hex Bolt, (1) 8mm Lock Washer and (1) 8mm x 28mm OD x 3mm Large Flat Washer, (**Figure 13B**). Do not tighten at this time. Line up the flat end of the Support Bracket with the hole in the Tube Bracket. Bolt the Support Bracket to the back of the Tube Bracket with (1) 10mm x 30mm Hex Bolt, (2) 10mm Flat Washers, (1) 10mm Lock Washer and (1) 10mm Hex Nut, (**Figure 13B**). Do not tighten hardware at this time.



8mm threaded hole in
bed reinforcement

(Fig 13A) Rear Bed Frame Mounting Bracket
and Support Bracket Locations Pictured

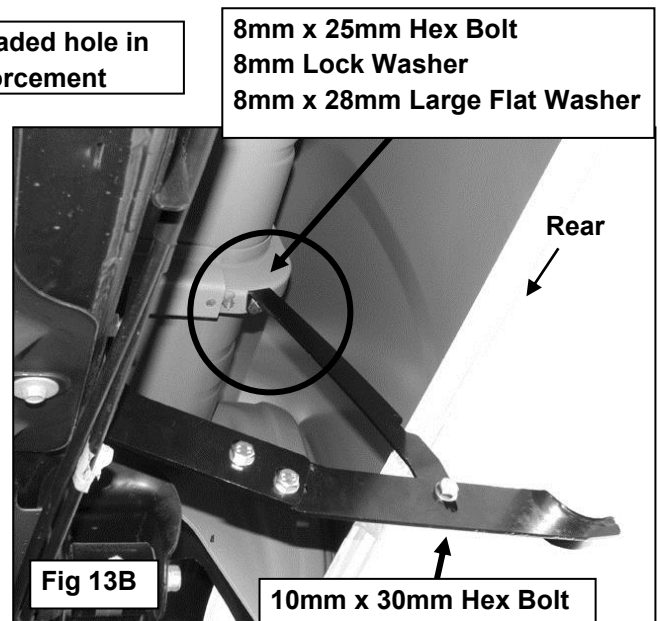
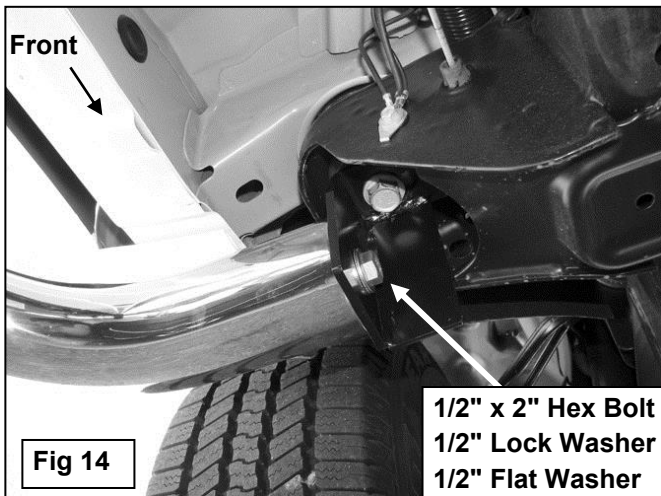

Fig 13B

8mm x 25mm Hex Bolt
8mm Lock Washer
8mm x 28mm Large Flat Washer

10mm x 30mm Hex Bolt
10mm Lock Washer
(2) 10mm Flat Washers
10mm Hex Nut

11. With assistance, carefully position the Side Bar up to the front Bracket and onto the (3) Mounting Brackets. Attach the front of the Sidebar to the Front Bracket with (1) 1/2" x 2" Hex Bolt, (1) 1/2" Lock Washer and (1) 1/2" Flat Washer, (**Figure 14**). Leave hardware loose.



12. Bolt the Sidebar to the Center, Rear and Bed Mounting Brackets with (6) 8mm Hex Bolts, (6) 8mm Lock Washers and (6) 8mm Flat Washers, (**Figure 15**). Do not tighten at this time.

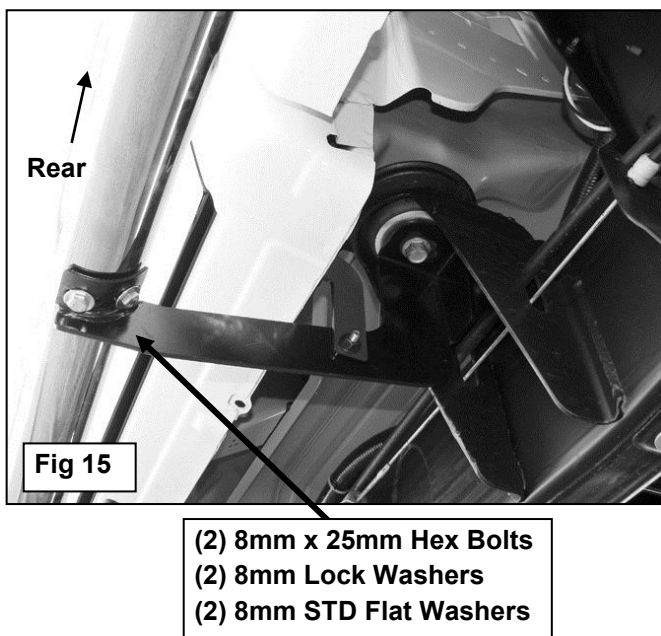

13. Level and adjust the Side Bar and tighten all hardware. **IMPORTANT:** Before tightening hardware, check all Bracket mounting locations for clearance between factory steel body mount brackets and Mounting Brackets.

14. Repeat **Steps 2 - 12** for passenger Side Bar installation.



PARTS IDENTIFICATION GUIDE

Driver Side tube packed using "Green" color foam sheet. Passenger Side tube packed using "White" color foam sheet

No.	Parts Identification
1	Passenger / Right 'Rear' Bracket marked "PR"
2	Driver / Left 'Rear' Bracket marked "DR"
3	Passenger / Right 'Center' Bracket marked "PC"
4	Driver / Left 'Center' Bracket marked "DC"
5	Passenger / Right 'Front' Bracket marked "PF"
6	Driver / Left 'Front' Bracket marked "DF"

Note:

- This guide is to identify the parts and not a reference for part count.
- For part count, refer Parts List.
- Product / Bracket image is representative and actual design may vary.

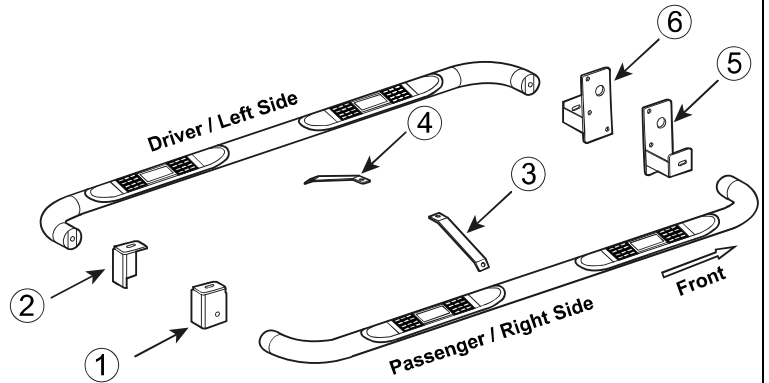

PRODUCT CARE

- Periodically check the product to ensure all fasteners are tight and components are intact.
- Regular waxing is recommended to protect the finish of the product.
- **Use ONLY Non-Abrasive automotive wax.** Use of any soap, polish or wax that contains an abrasive is detrimental and can scratch the finish leading to corrosion.
- Aluminum polish may be used to polish small scratches and scuffs for **Stainless Steel finish.**
- Mild soap may be used to clean the product for both **Stainless Steel and Black finish.**

FAQ's

1. Hardware's are not of correct size.

In GMC / Chevrolet truck model 2006 & up, customer needs to reuse the factory body bolts to install the bracket. If your vehicle is not GMC / Chevrolet 2006 & up, ensure that holes are not partially covered with any plastic grommet or rust? If it is, remove the plastic grommet & rust from the thread holes & re-try the installation.

2. Mounting Bracket are not getting Installed properly.

In some cases Illustration images shown in Installation manual may not be the exactly same as per actual vehicle images ,also if Driver / Passenger side mounting brackets are very identical in the design, suggest referring Parts Identification guide to avoid fitment issue.

3. Products are thumping / rattling after installation.

Ensure that all required mounting brackets / hardware's are installed & tighten correctly. Suggest using white lithium / regular grease between the metal to metal contact surfaces.

4. Side Bar is not aligning with vehicle / Step Pads are not aligning with vehicle doors.

Side bar may be interchanged or mounting brackets are not installed at the correct position in the vehicle. Refer Parts identification guide.

5. Missing / Excess Hardware.

Recheck hardware count as per the part list.

6. Product not installing properly.

Ensure make model year, cab length and bed size of your vehicle is listed in the application. All installation steps are followed correctly.