



4" Oval Straight Side Bar

Part No. A1551S /B



Fits: **Current 1500 SILVERADO REGULAR CAB(EXCLUDES DIESEL W/DEF)**

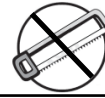

60-180 min

Cutting Not Required

Drilling Not Required



REMOVE CONTENTS FROM BOX. VERIFY ALL PARTS ARE PRESENT.



READ INSTRUCTIONS CAREFULLY BEFORE STARTING INSTALLATION.

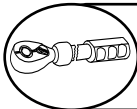

DO NOT OVER TORQUE. STANDARD OPERATING LOAD FOR TIGHTEN BODY MOUNT NUTS & BOLTS VARIES FROM 45 TO 65 FOOT POUND.

PARTS LIST:

Qty	Part Description	Qty	Part Description
1	Driver/Left Sidebar	8	8-1.25mm x 30mm Hex Bolts
1	Passenger/Right Sidebar	8	8-1.25mm x 25mm Combo Bolts
4	Mounting Brackets	8	8mm Lock Washers
		8	8mm x 24mm x 2mm Flat Washers

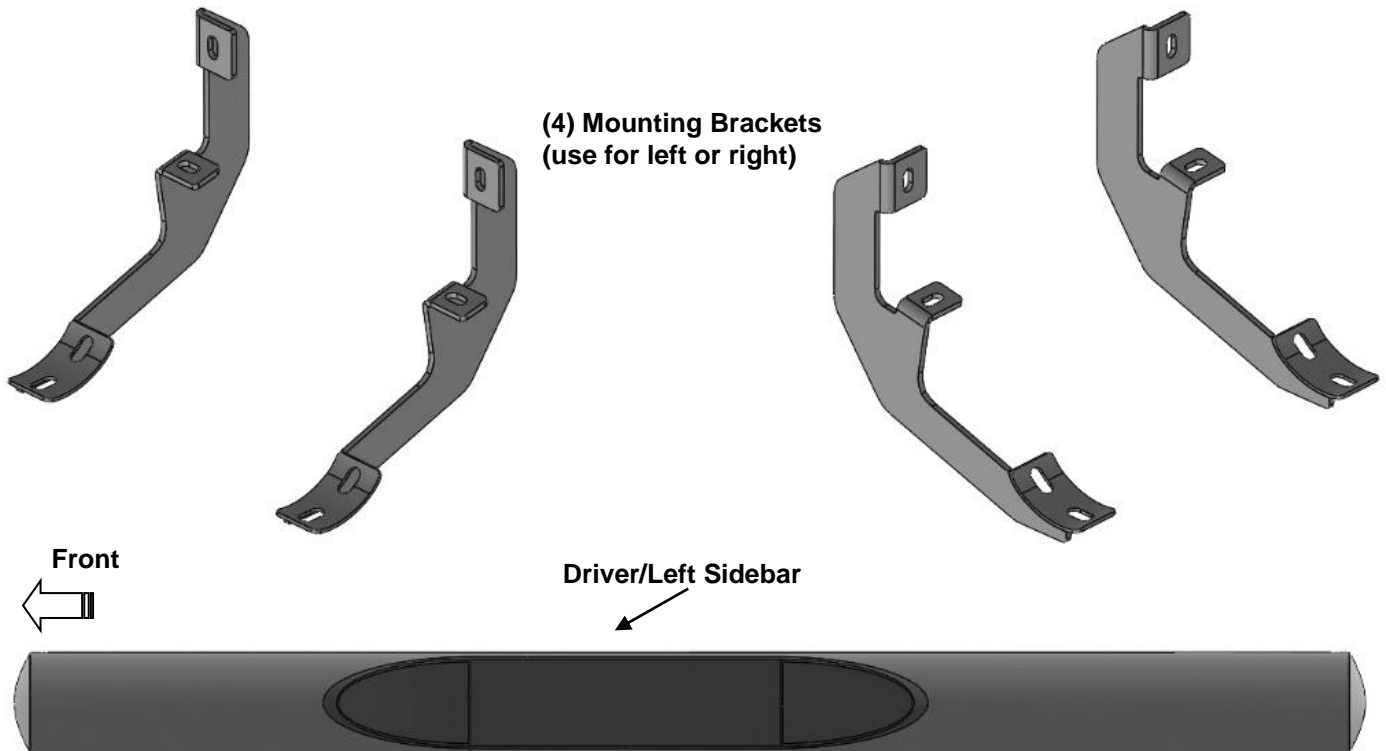

PROCEDURE:

REMOVE CONTENTS FROM BOX. VERIFY ALL PARTS ARE PRESENT. READ INSTRUCTIONS CAREFULLY BEFORE STARTING INSTALLATION. ASSISTANCE IS RECOMMENDED.

1. Start the installation under the Driver/Left side of the vehicle. Locate the plastic plugs along the bottom edge of the body, **(Figure 1)**. Remove the plastic plugs from each mounting location, **(Figure 2)**. Directly above each threaded insert is a top mounting location on the side of the body panel. Hold a Bracket up in place to

help determine the correct mounting holes to use along the body. **NOTE:** Thread an 8mm Hex Bolt into the threaded inserts to clear paint as required.

2. Select (1) Mounting Bracket. Starting at the front of the Driver/Left side, attach the Mounting Bracket to the factory threaded holes with (2) 8mm Hex Bolts, (2) 8mm Lock Washers and (2) 8mm Flat Washers, **(Figure 3)**. Do not fully tighten hardware.
3. Repeat **Steps 1 & 2** to attach (1) Mounting Bracket to the rear mounting location, **(Figure 4)**.
4. Select the Driver/Left Sidebar. Use the illustration above to help determine the correct Sidebar. Place the Sidebar on top of the Brackets. **IMPORTANT:** Do not slide, (front to back), the Sidebar on the Brackets or damage to the finish may result.
5. Attach the Sidebar to the Brackets with (6) 8mm Combo Bolts, **(Figure 5)**.
6. Level and adjust the Sidebar and fully tighten all hardware.
7. Repeat **Steps 1—6** to install the Passenger/Right Sidebar.
8. Do periodic inspections to the installation to make sure that all hardware is secure and tight.

Driver/Left side Installation Pictured

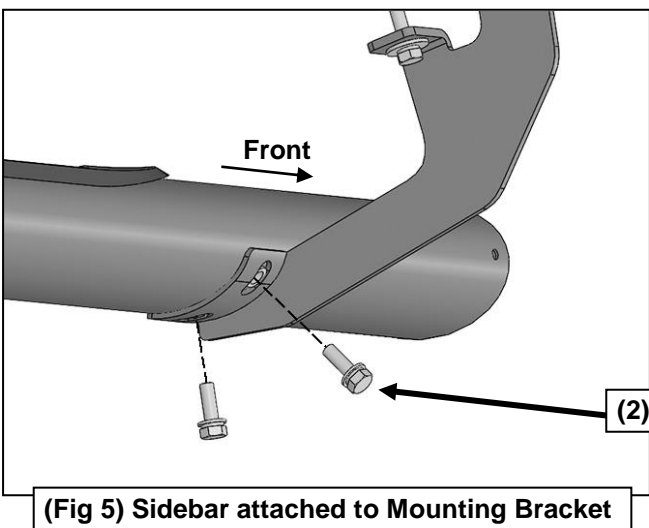
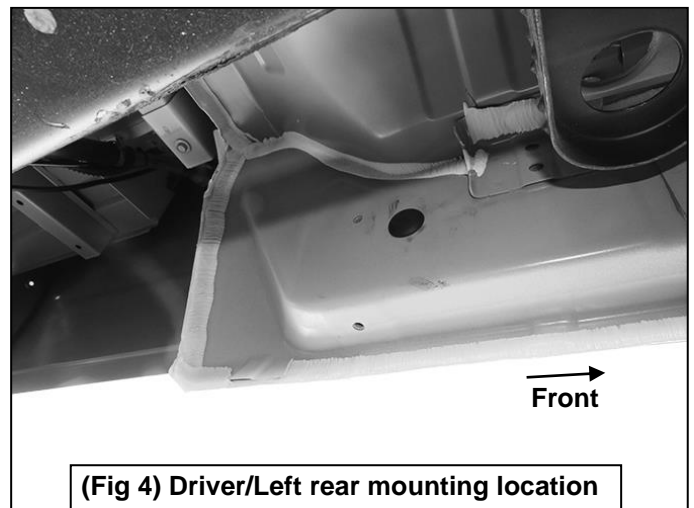
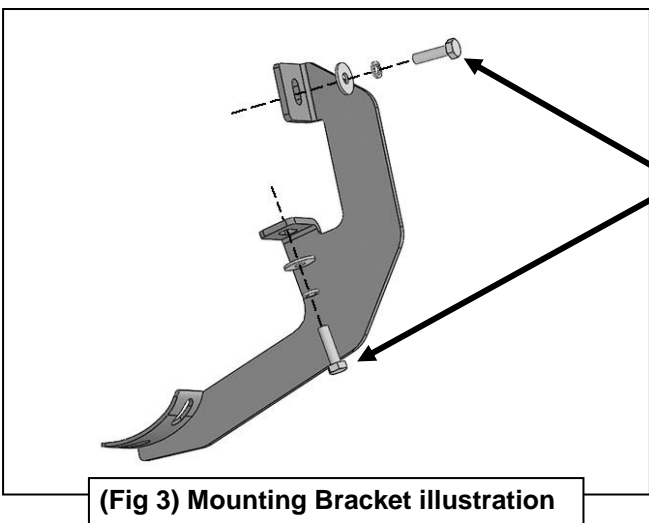
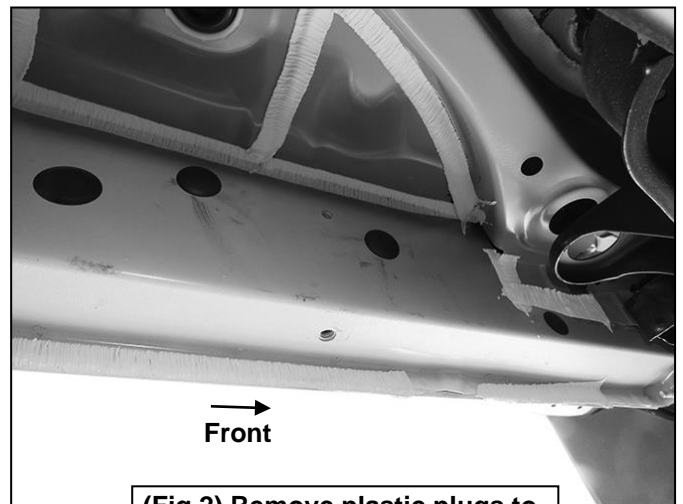
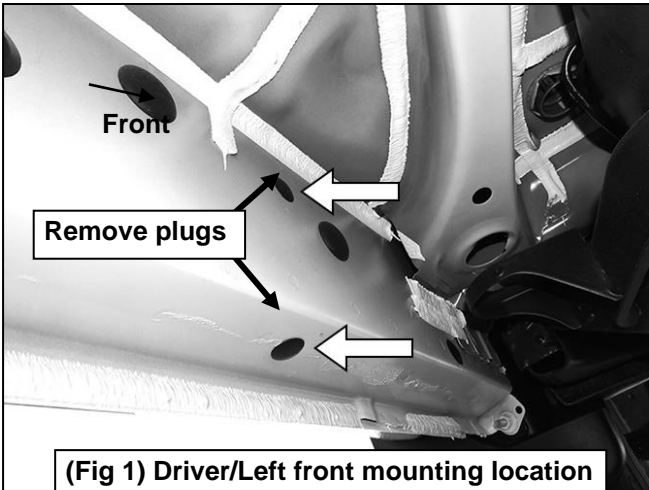

No.	Parts Identification
1	Passenger / Right 'Rear' Bracket marked "PR"
2	Driver / Left 'Rear' Bracket marked "DR"
3	Passenger / Right 'Center' Bracket marked "PC"
4	Driver / Left 'Center' Bracket marked "DC"
5	Passenger / Right 'Front' Bracket marked "PF"
6	Driver / Left 'Front' Bracket marked "DF"
<p>Note:</p> <ul style="list-style-type: none"> ➤ This guide is to identify the parts and not a reference for part count. ➤ For part count, refer Parts List. ➤ Product / Bracket image is representative and actual design may vary. 	

