



# 4" Oval Nerf Bar

Part No. A1541S/B



Fits: **2017**

**Honda Ridgeline**



REMOVE CONTENTS FROM BOX. VERIFY ALL PARTS ARE PRESENT.



READ INSTRUCTIONS CAREFULLY BEFORE STARTING INSTALLATION.

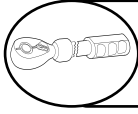

DO NOT OVER TORQUE. STANDARD OPERATING LOAD FOR TIGHTEN BODY MOUNT NUTS & BOLTS VARIES FROM 45 TO 65 FOOT POUND.



60-180 min



Cutting Not Required



Drilling Not Required

### PARTS LIST:

Qty	Part Description	Qty	Part Description
1	Driver/Left Sidebar	1	Driver/Left Rear Mounting Bracket
1	Passenger/Right Sidebar	1	Passenger/Right Rear Mounting Bracket
1	Driver/Left Front Mounting Bracket	12	8mm x 25mm Hex Bolts
1	Passenger/Right Front Mounting Bracket	12	8mm x 24mm x 2mm Flat Washers
1	Driver/Left Center Mounting Bracket	12	8mm Lock Washers
1	Passenger/Right Center Mounting Bracket	12	8mm Combo Hex Bolts w-washers

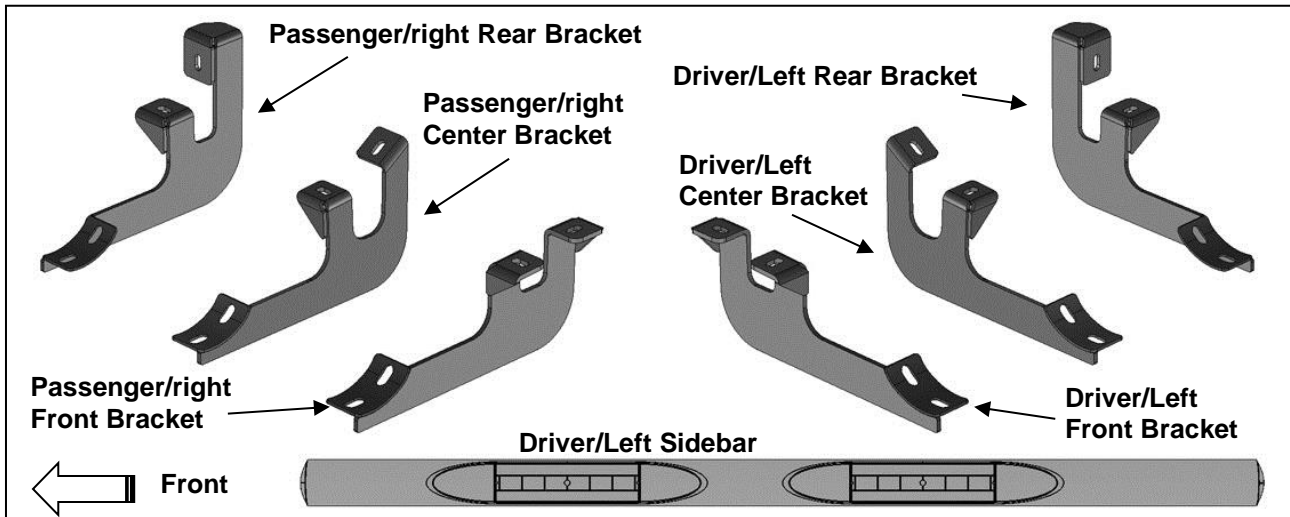

## INSTALLATION PROCEDURE:

1. Starting on the driver/left front of the vehicle, locate the two factory 8mm threaded holes located in the bottom of the floor panel, **(Figure 1)**. **NOTE:** Brackets install in the factory running board mounting locations. Threaded holes may be covered with insulation. Clean mounting locations as required for proper Bracket installation.

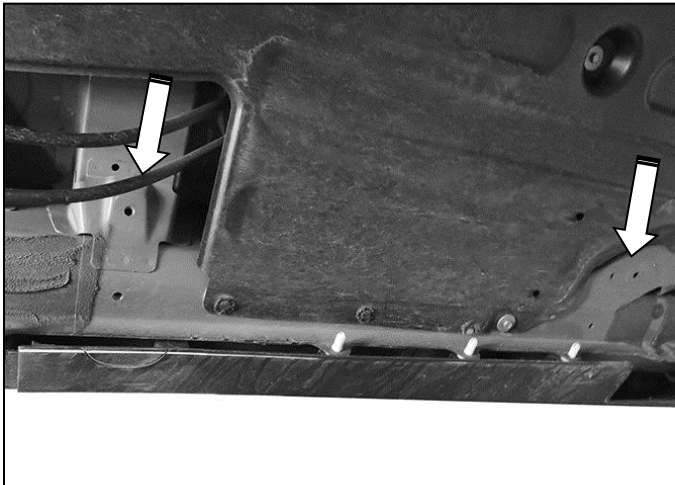

**(Fig 1) Driver/left front and center mounting locations**

2. Select the driver/left Front Bracket, **(Figure 2)**. Attach the Bracket to the threaded holes with (2) 8mm x 25mm Hex Bolts, (2) 8mm Lock Washers and (2) 8mm Flat Washers, **(Figures 2, 6 & 8)**. Snug but do not tighten hardware at this time.

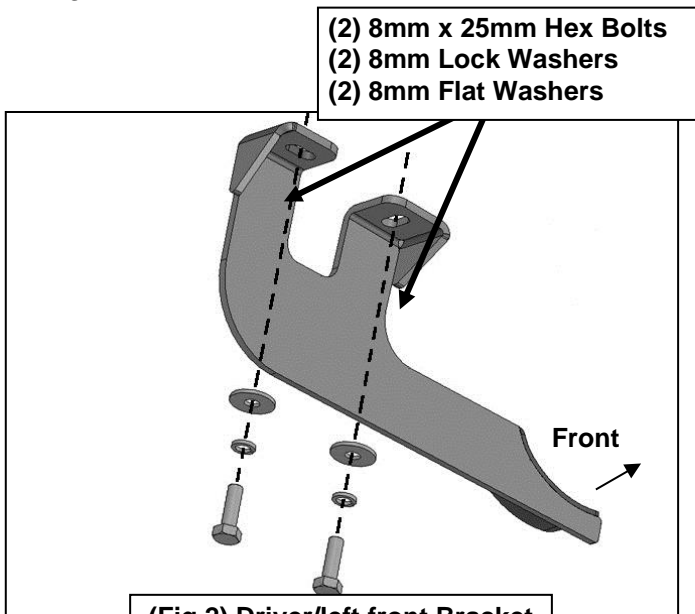

**(Fig 2) Driver/left front Bracket**

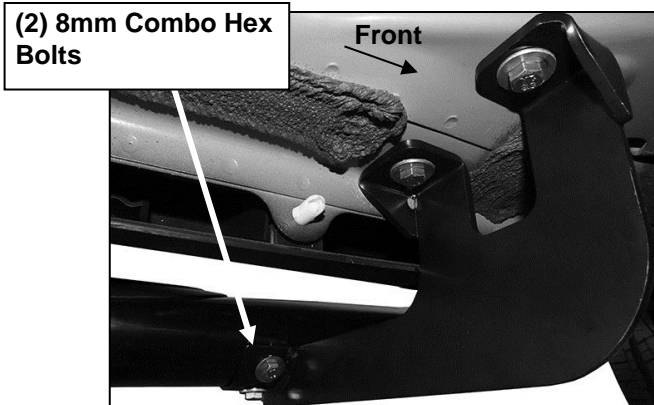

**(Fig 6) Driver/left front Bracket installed**

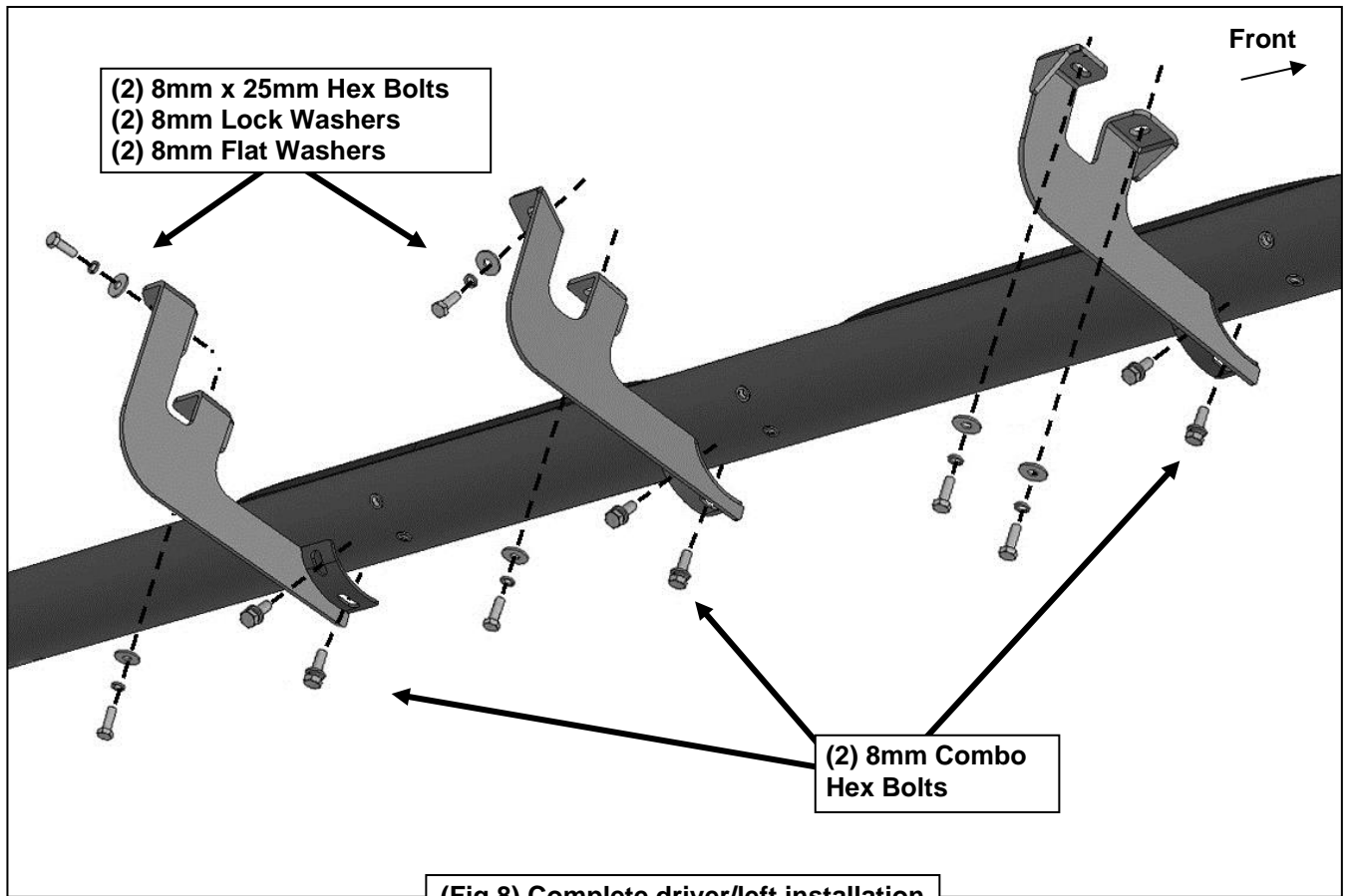

(Fig 8) Complete driver/left installation

3. Move to the center of the vehicle. Locate the two threaded holes in the bottom of the floor panel and body support, (Figure 1). Repeat Steps 2 & 3 to attach driver/left Center Bracket, (Figures 3 & 8).

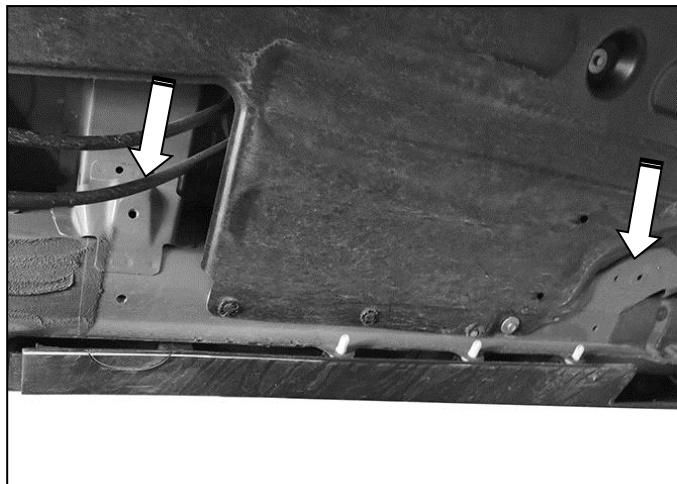

(Fig 1) Driver/left front and center mounting locations

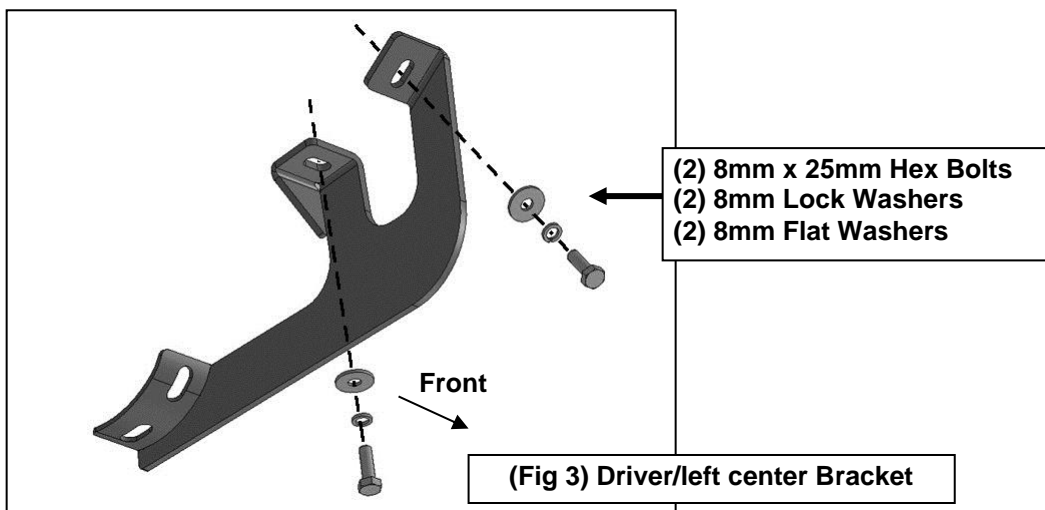

(Fig 3) Driver/left center Bracket

4. Next, move to the rear of the vehicle. Locate the holes in the bottom and inner side of the floor panel, (Figure 4). Repeat Steps 2 & 3 to install the driver/left Rear Bracket, (Figures 5, 7 & 8).

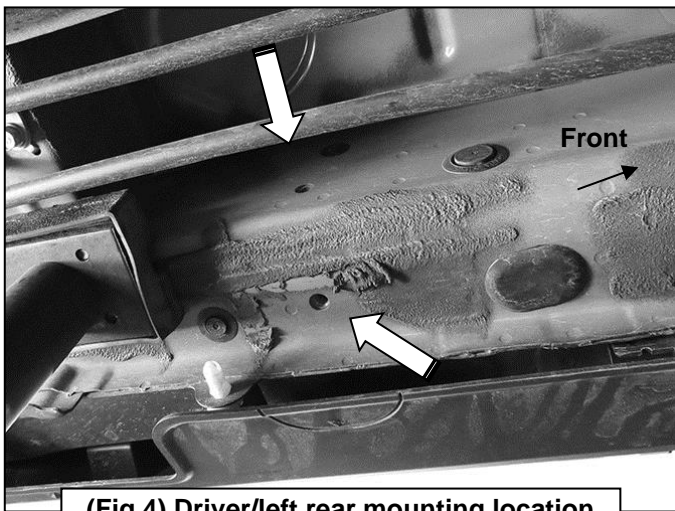

(Fig 4) Driver/left rear mounting location

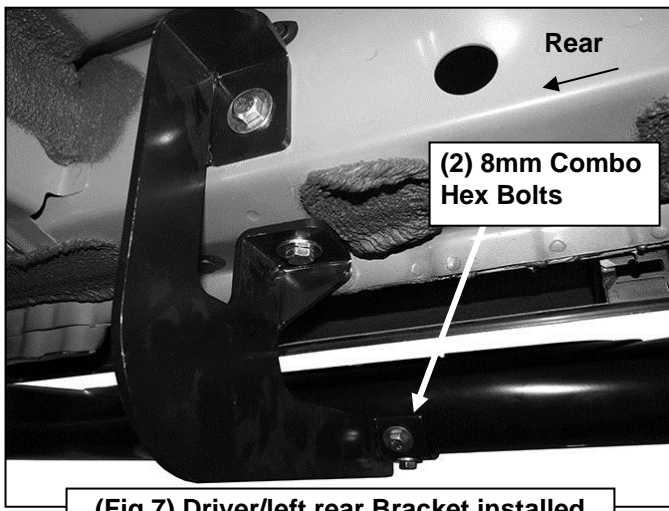

(Fig 7) Driver/left rear Bracket installed

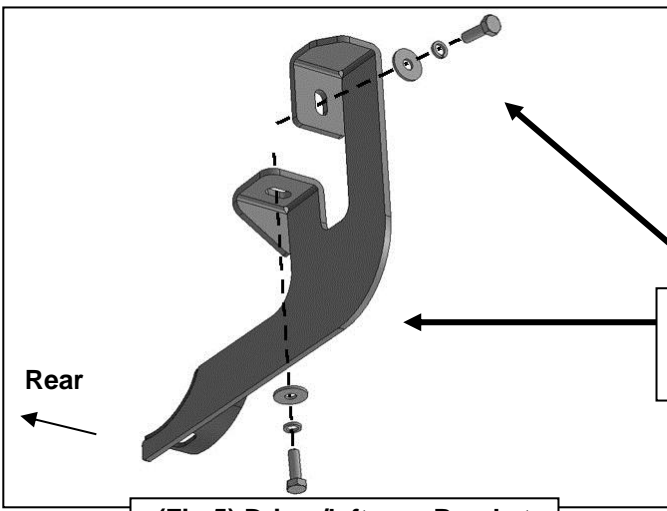

(Fig 5) Driver/left rear Bracket

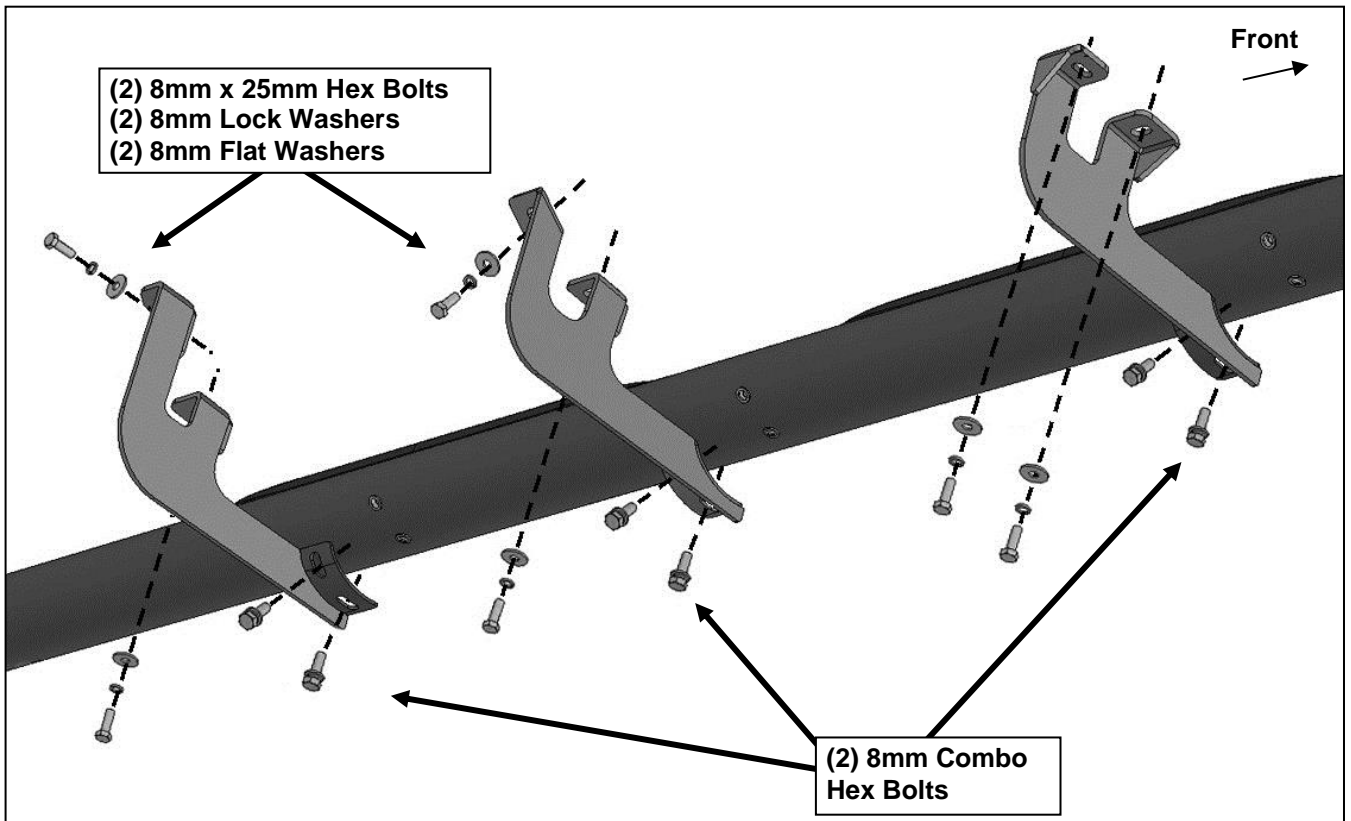

(Fig 8) Complete driver/left installation

5. Carefully position the driver/left Sidebar onto the Brackets. **IMPORTANT:** Do not slide, (front to back or rotate), the Sidebar on the Brackets or damage to the finish may result. Attach the Sidebar to the Brackets with the included (6) 8mm x 25mm Combination Hex Bolts, (Figures 6—8). Do not tighten hardware at this time.

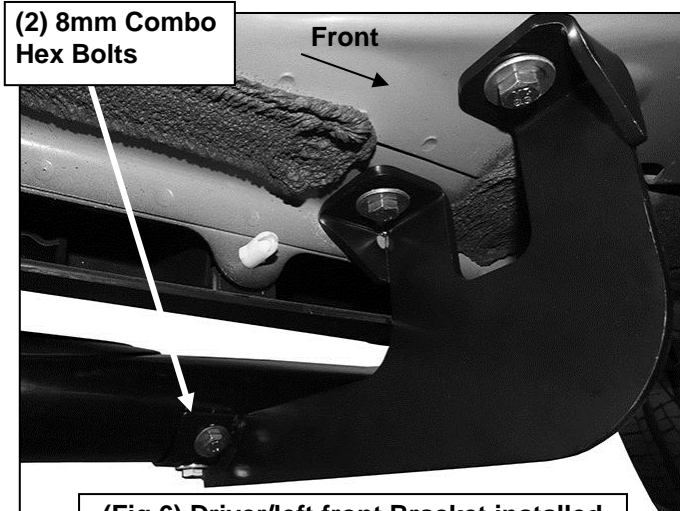

(Fig 6) Driver/left front Bracket installed

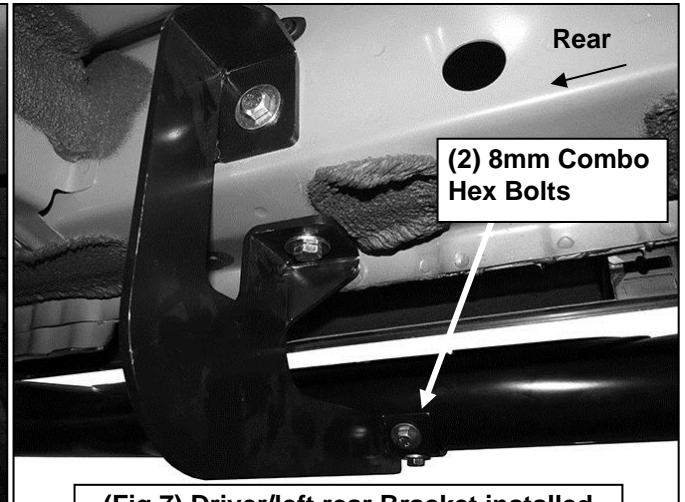

(Fig 7) Driver/left rear Bracket installed

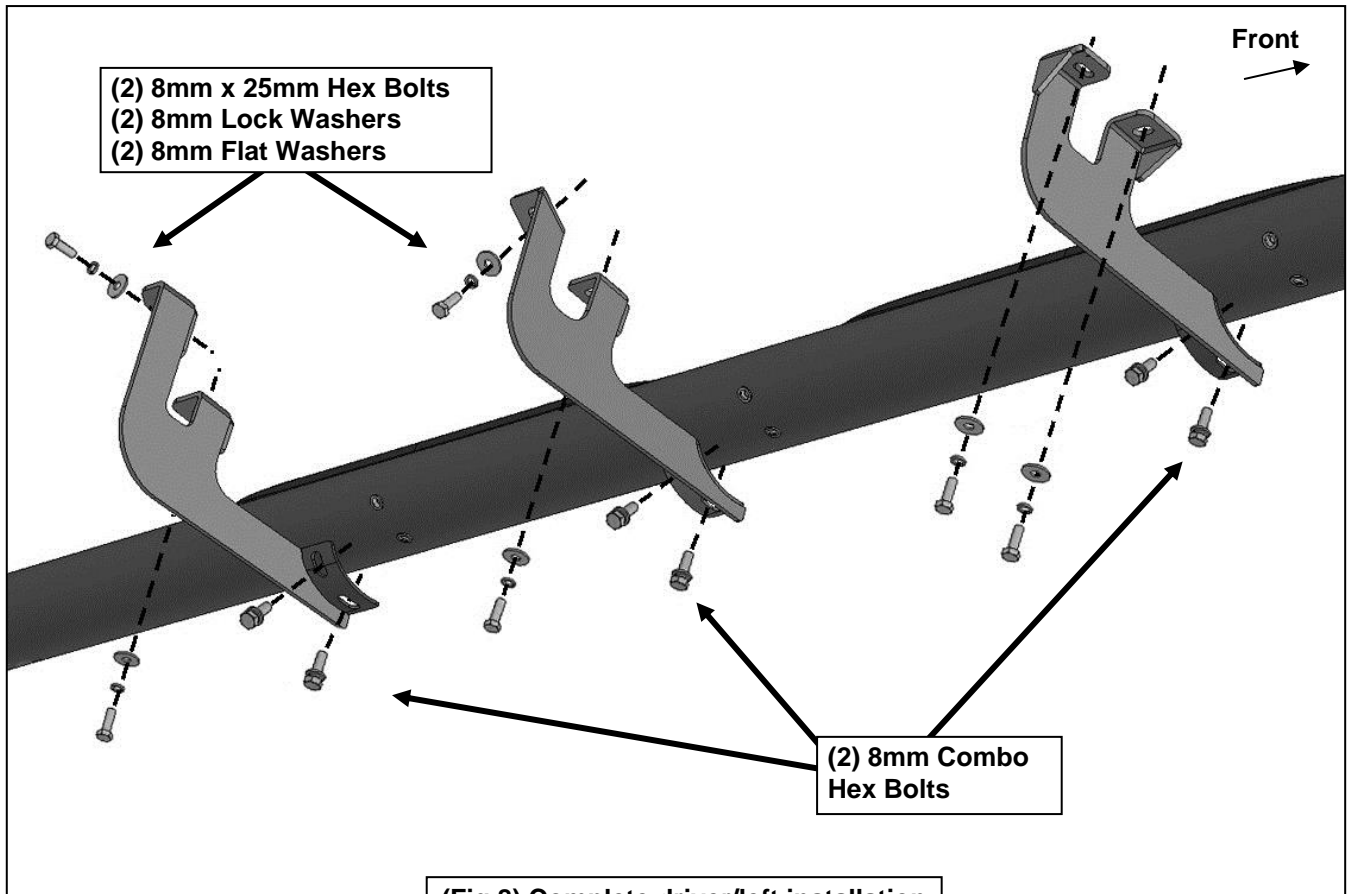

(Fig 8) Complete driver/left installation

6. Align the Sidebar properly and tighten all hardware.
7. Repeat **Steps 2—7** for the passenger/right Sidebar installation.
8. Do periodic inspections to the installation to make sure that all hardware is secure and tight.

## PARTS IDENTIFICATION GUIDE

**Driver Side tube packed using "Green" color foam sheet. Passenger Side tube packed using "White" color foam sheet**

No.	Parts Identification
1	Passenger / Right 'Rear' Bracket marked "PR"
2	Driver / Left 'Rear' Bracket marked "DR"
3	Passenger / Right 'Center' Bracket marked "PC"
4	Driver / Left 'Center' Bracket marked "DC"
5	Passenger / Right 'Front' Bracket marked "PF"
6	Driver / Left 'Front' Bracket marked "DF"

**Note:**

- This guide is to identify the parts and not a reference for part count.
- For part count, refer Parts List.
- Product / Bracket image is representative and actual design may vary.

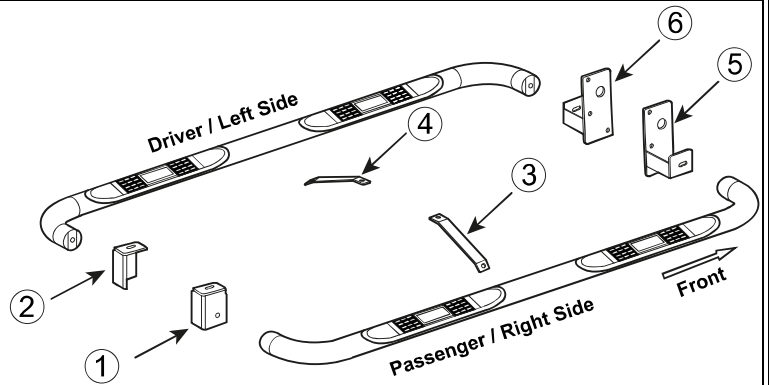

## PRODUCT CARE

- Periodically check the product to ensure all fasteners are tight and components are intact.
- Regular waxing is recommended to protect the finish of the product.
- **Use ONLY Non-Abrasive automotive wax.** Use of any soap, polish or wax that contains an abrasive is detrimental and can scratch the finish leading to corrosion.
- Aluminum polish may be used to polish small scratches and scuffs for **Stainless Steel finish.**
- Mild soap may be used to clean the product for both **Stainless Steel and Black finish.**

## FAQ's

### 1. Hardware's are not of correct size.

*In GMC / Chevrolet truck model 2006 & up, customer needs to reuse the factory body bolts to install the bracket. If your vehicle is not GMC / Chevrolet 2006 & up, ensure that holes are not partially covered with any plastic grommet or rust? If it is, remove the plastic grommet & rust from the thread holes & re-try the installation.*

### 2. Mounting Bracket are not getting Installed properly.

*In some cases Illustration images shown in Installation manual may not be the exactly same as per actual vehicle images ,also if Driver / Passenger side mounting brackets are very identical in the design, suggest referring Parts Identification guide to avoid fitment issue.*

### 3. Products are thumping / rattling after installation.

*Ensure that all required mounting brackets / hardware's are installed & tighten correctly. Suggest using white lithium / regular grease between the metal to metal contact surfaces.*

### 4. Side Bar is not aligning with vehicle / Step Pads are not aligning with vehicle doors.

*Side bar may be interchanged or mounting brackets are not installed at the correct position in the vehicle. Refer Parts identification guide.*

### 5. Missing / Excess Hardware.

*Recheck hardware count as per the part list.*

### 6. Product not installing properly.

*Ensure make model year, cab length and bed size of your vehicle is listed in the application. All installation steps are followed correctly.*

## Check out these other TrailFX Products!!



*Keystone Automotive Operations Inc. (KAO) warrants this product to be free of defects in material and workmanship at the time of purchase by the original retail consumer. KAO disclaims any other warranties, express or implied, including the warranty of fitness for a particular purpose or an intended use. If the product is found to be defective, KAO may replace or repair the product at our option, when the product is returned prepaid, with proof of purchase. Alteration to, improper installation, or misuse of this product voids the warranty. KAO's liability is limited to repair or replacement of products found to be defective, and specifically excludes liability for any incidental or consequential loss or damage.*