



# 4" Oval Nerf Bar

Part No. A1535S/B



Fits: **2009-2015 Dodge Ram 1500 Reg Cab**  
**2010-2015 Dodge Ram 2500/3500/4500/5500 Reg.Cab**



REMOVE CONTENTS FROM BOX. VERIFY ALL PARTS ARE PRESENT.



READ INSTRUCTIONS CAREFULLY BEFORE STARTING INSTALLATION.

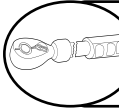

DO NOT OVER TORQUE. STANDARD OPERATING LOAD FOR TIGHTEN BODY MOUNT NUTS & BOLTS VARIES FROM **45** TO **65** FOOT POUND.



60-180 min

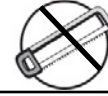

Cutting Not Required



Drilling Not Required

### PARTS LIST:

Qty	Part Description	Qty	Part Description
1	Driver/Left Sidebar	4	10-1.5mm x 35mm Hex Bolts
1	Passenger/Right Sidebar	4	10mm x 27mm OD x 3mm Flat Washers
1	Driver/Left Front Mounting Bracket	4	10mm Lock Washers
1	Driver/Left Front Support Bracket	5	8-1.25 x 30mm Hex Bolts
1	Passenger/Right Front Mounting Bracket	8	8-1.25 x 25mm Hex Bolts
1	Driver/Left Rear Mounting Bracket	14	8mm x 24mm x 2mm Flat Washers
1	Passenger/Right Rear Mounting Bracket	12	8mm Lock Washers
4	12mm Plastic Retainers	1	8mm Nylon Lock Nut
4	12mm x 35mm Bolt x 10mm Nut Plates	4	6mm x 22mm x 2mm Flat Washers
3	12mm x 32mm OD x 3mm Flat Washers	2	6mm x 25mm Hex Bolts
3	12mm Lock Washers	2	6mm Nylon Lock Nuts
3	12mm Hex Nuts		

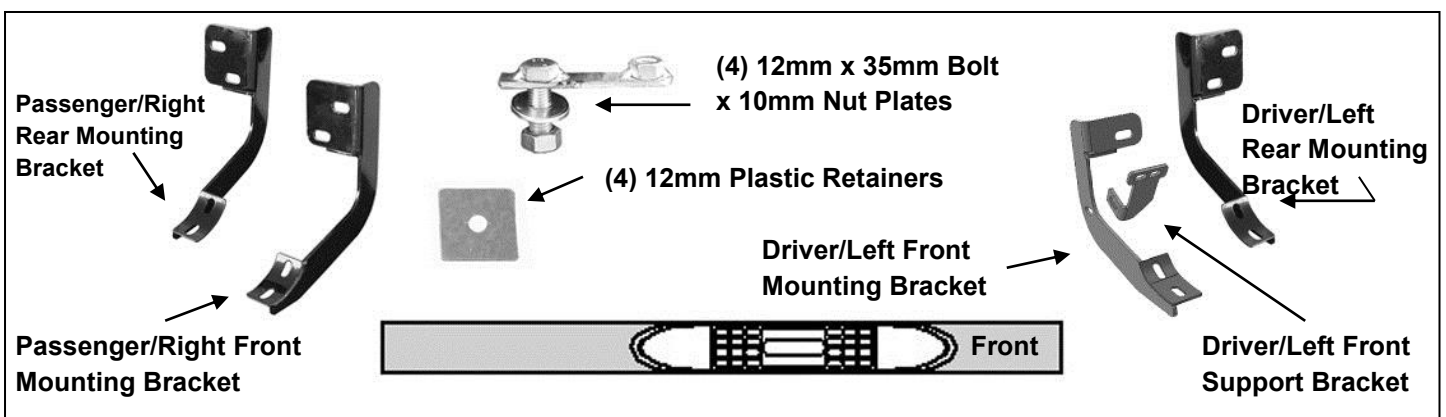

### INSTALLATION PROCEDURE:

- Starting at the driver side-front of the vehicle, remove the sealing tape covering the factory holes on the side of the inner panel, (Figure 1 & 4).
- Determine the correct procedure to attach the driver side front Bracket for your model/year:  
**Models without factory threaded inserts in body panel:**

- a. Partially thread a 12mm Plastic Retainer onto the threaded end of a 12mm Bolt and Nut Plate, **(Figure 2)**. Insert the Bolt and Nut Plate into the oval hole and tighten the Plastic Retainer, **(Figure 3)**. **NOTE:** The Plastic Retainer is designed to keep the Bolt/Nut Plate from falling into the body panel and to aid in Bracket installation.
- b. Select the driver side front Mounting Bracket, **(Figure 5)**. Rotate the 12mm Bolt and Nut plate until the threaded nut lines up with the hole in the Mounting Bracket and body, **(Figure 3)**. Attach the Bracket to the threaded Nut Plate with (1) 10mm x 35mm Hex Bolt, (1) 10mm Lock Washer and (1) 10mm Flat Washer, **(Figures 5 & 7)**. Do not fully tighten hardware at this time.

**Models with factory threaded inserts:**

- a. Attach the driver side Front Bracket to the threaded insert with (1) 8mm x 30mm Hex Bolt, (1) 8mm Lock Washer and (1) 8mm Flat Washer, **(Figures 4, 5 & 7)**. Leave hardware loose.
3. Next, select the driver side front Support Bracket. Attach the Bracket to the back of the front Bracket with (1) 8mm x 30mm Hex Bolt, (2) 8mm Flat Washers and (1) 8mm Nylon Lock Nut, **(Figures 5 & 7)**. Rotate the Support Bracket to the back of the pinch weld. Line up the slot in the top of the Support Bracket with the (2) factory holes in the pinch weld. Attach the Bracket to the pinch weld with (2) 6mm Hex Bolts, (4) 6mm Flat Washers and (2) 6mm Nylon Lock Nuts, **(Figures 6 & 7)**. Do not fully tighten hardware at this time. **IMPORTANT:** 2009-10 models are not equipped with factory holes and will require drilling through the pinch weld to attach the Support Bracket. Do not drill through pinch weld at this time, **(see Step 7)**.
4. Move along the cab to the rear mounting location, **(Figure 8)**. Select (1) 12mm Bolt/Nut Plate. Repeat **Step 3** to install the Bolt/Nut Plate. Select the driver side rear Bracket. Attach the Bracket to the Bolt/Nut Plate with (1) 12mm Flat Washer, (1) 12mm Lock Washer and (1) 12mm Hex Nut, **(Figure 9)**. Do not tighten hardware at this time. Line up the remaining hole in the Bracket with the hole in the inner body panel. Rotate the Bolt and Nut Plate until the threaded end (Nut) lines up with the hole in the Bracket. Secure with (1) 10mm x 35mm Hex Bolt, (1) 10mm Lock Washer and (1) 10mm Flat Washer, **(Figure 9)**.
  - a. **IMPORTANT NOTE:** Models with threaded insert, attach the Bracket to the threaded insert with (1) 8mm x 30mm Hex Bolt, (1) 8mm Lock Washer and (1) 8mm Flat Washer. The 10mm hardware will not be required **(Step 5)**. Snug but do not tighten hardware.
5. Once the front and rear brackets have been installed, carefully position the driver Sidebar onto the Mounting Brackets. Attach the Sidebar to the cradles on the Mounting Brackets using the included (4) 8mm x 25mm Hex Bolts, (4) 8mm Lock Washers and (4) 8mm Flat Washers, **(Figures 10 & 11)**. Do not tighten hardware at this time.
6. Properly level and adjust the Sidebar and fully tighten all hardware.

**2009-10 models requiring drilling for driver side front Support Bracket:**

- a. Make sure the Sidebar is level to the vehicle. Line up the slot on the Support Bracket with the back of the pinch weld. Mark the location of the slot onto the pinch weld.
- b. Drill (2) 1/4" holes through the pinch weld. **IMPORTANT:** Do not drill too close to the bottom edge of the pinch weld. Drill the holes toward the outside of the marked slot.
- c. Attach the Support Bracket to the pinch weld with (2) 6mm Hex Bolts, (4) 6mm Flat Washers and (2) 6mm Nylon Lock Nuts. Check for level then fully tighten all hardware.
7. Move to the passenger side of the vehicle. Remove tape covering front and rear locations. Repeat **Steps 5—7** for passenger side Mounting Bracket installation, **(Figure 11)**. **NOTE:** Refer to the illustration on **Page 1** to identify the correct Mounting Bracket for each of the remaining locations.
8. Do periodic inspections to the installation to make sure that all hardware is secure and tight.

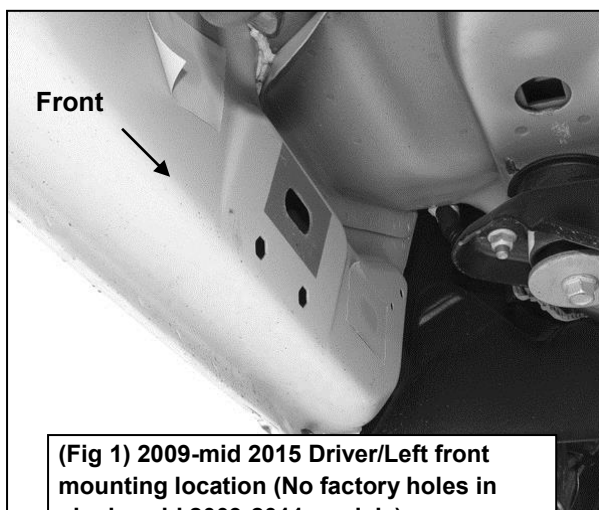

**(Fig 1) 2009-mid 2015 Driver/Left front mounting location (No factory holes in pinch weld 2009-2011 models)**

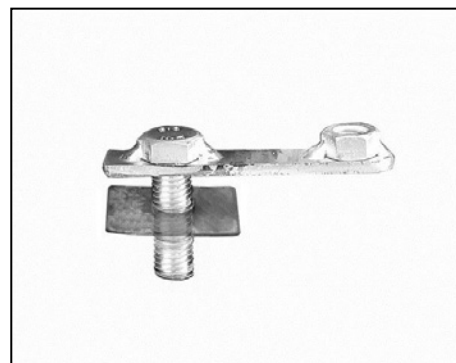

**(Fig 2) 12mm Bolt-10mm Nut Plate w-Retainer, NOTE: 10mm hardware not required on models with threaded inserts**

12mm x 35mm Bolt/10mm Nut Plate  
12mm Plastic Retainer

Rotate Bolt/Nut Plate to line up correct threaded hole with body panel and hole in Mounting Bracket (see arrow)

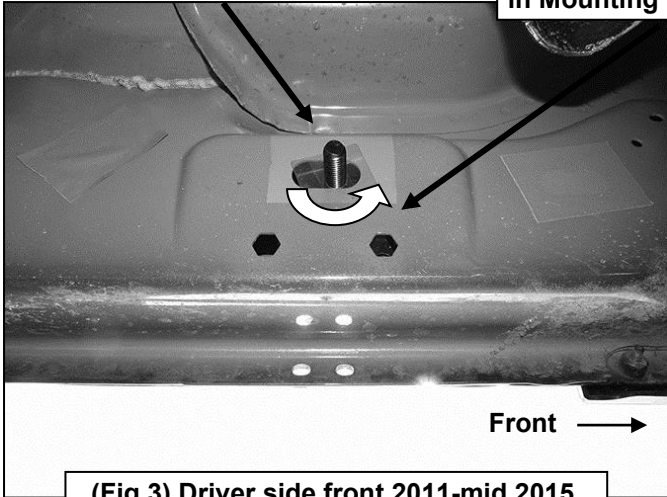

(Fig 3) Driver side front 2011-mid 2015.  
NOTE no threaded insert in body panel

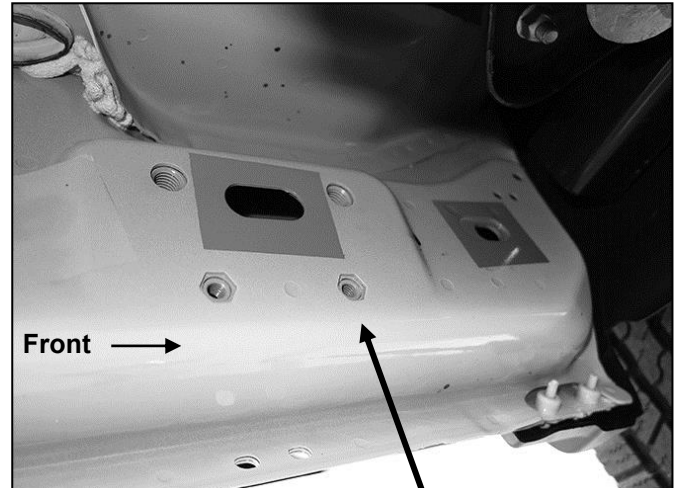

(Fig 4) Driver side front mid 2015-on and example of all models with factory installed threaded inserts

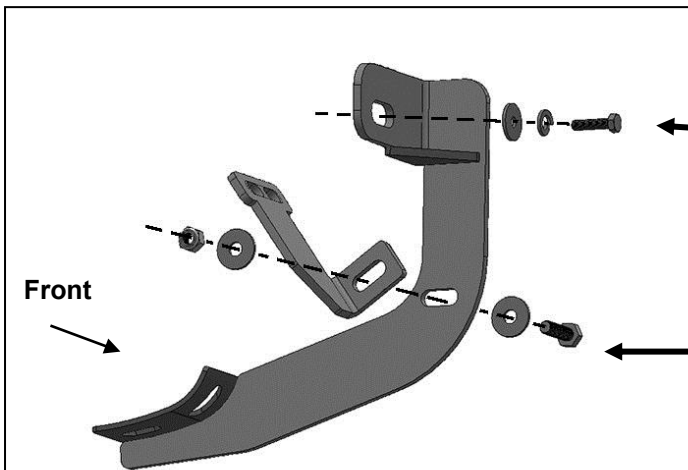

(Fig 5) Driver/Left front Mounting Bracket assembly

Models without threaded insert using Bolt/Nut Plate, use:  
10mm x 35mm Hex Bolt  
10mm Lock Washer  
10mm Flat Washer  
Models with threaded insert use:  
8mm x 30mm Hex Bolt  
8mm Lock Washer  
8mm Flat Washer

8mm x 30mm Hex Bolt  
(2) 8mm Flat Washers  
8mm Nylon Lock Nut

Models without threaded insert using Bolt/Nut Plate, use:  
10mm x 35mm Hex Bolt  
10mm Lock Washer  
10mm Flat Washer  
Models with threaded insert use:  
8mm x 30mm Hex Bolt  
8mm Lock Washer  
8mm Flat Washer

(2) 6mm Hex Bolt  
(4) 6mm Flat Washers  
(2) 6mm Nylon Lock Nut

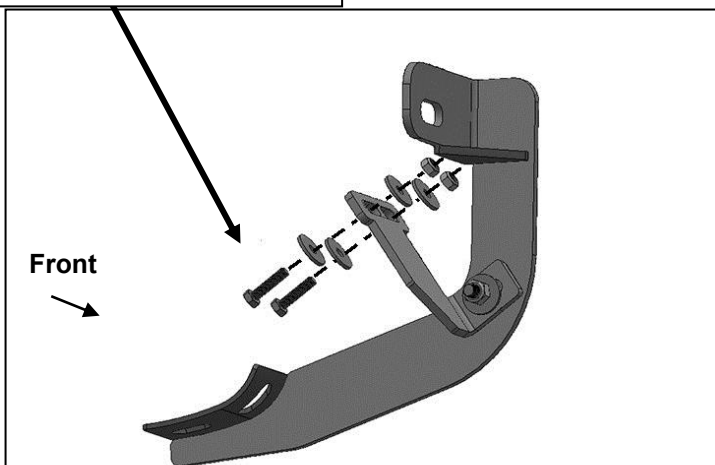

(Fig 6) Attach Support Bracket to back of pinch weld

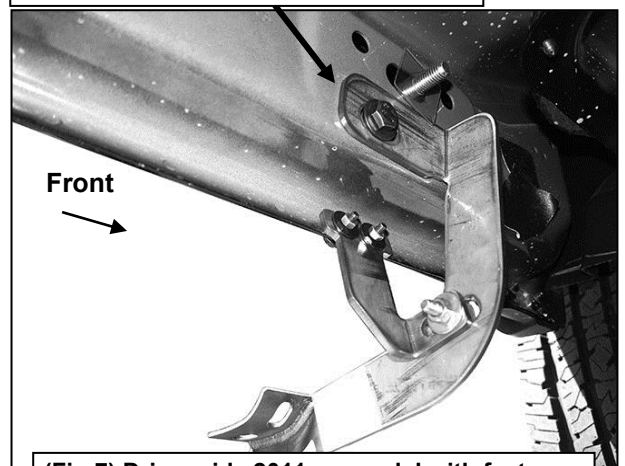

(Fig 7) Driver side 2011-on model with factory holes in pinch weld pictured.

**IMPORTANT** 2009-2010 models without holes in pinch weld will require drilling 1/4" holes through pinch weld to attach driver side front support bracket. Do complete installation of sidebars first, level sidebar before drilling holes for support bracket.

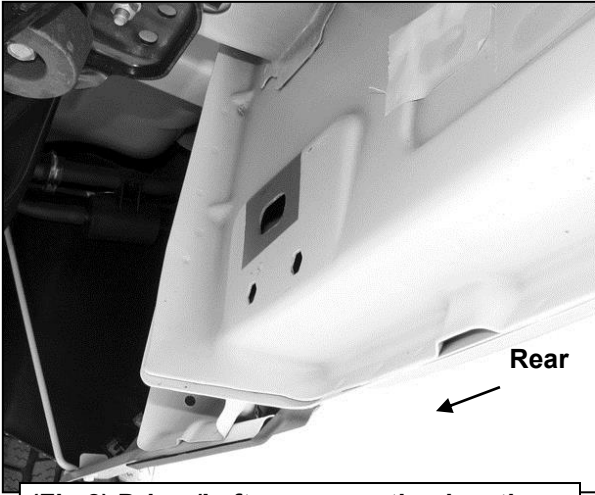

**(Fig 8) Driver/Left rear mounting location**

**8mm x 25mm Hex Bolts  
8mm Flat Washers  
8mm Lock Washers**

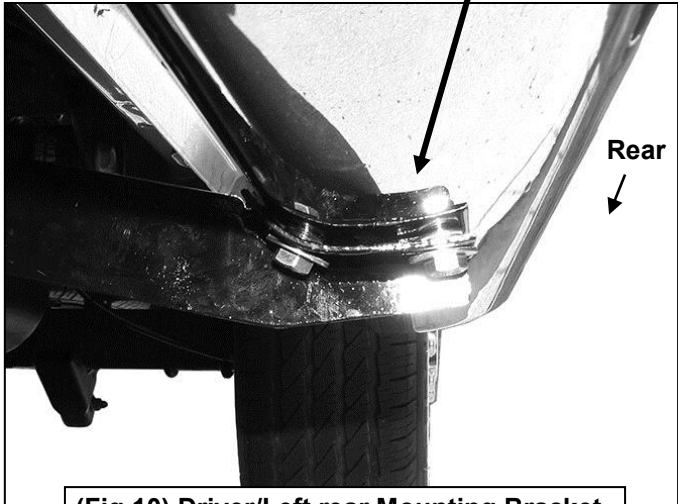

**(Fig 10) Driver/Left rear Mounting Bracket**



**Complete Installation**

**Models without threaded insert using Bolt/Nut Plate, use:  
10mm x 35mm Hex Bolt  
10mm Lock Washer  
10mm Flat Washer**

**Models with threaded insert use:  
8mm x 30mm Hex Bolt  
8mm Lock Washer  
8mm Flat Washer**

**12mm Flat Washer  
12mm Lock Washer  
12mm Hex Nut**

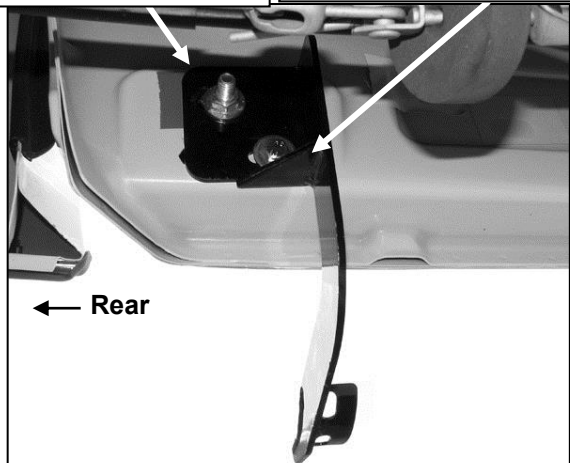

**(Fig 9) Driver/Left rear Mounting Bracket**

**8mm x 25mm Hex Bolts  
8mm Flat Washers  
8mm Lock Washers**

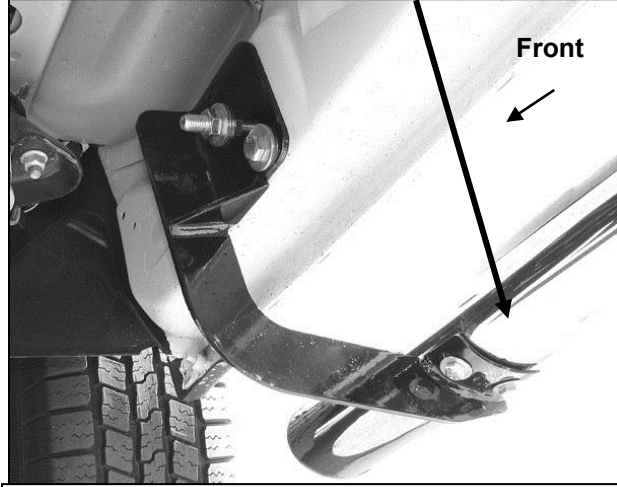

**(Fig 11) Passenger/right front Mounting Bracket**

## PARTS IDENTIFICATION GUIDE

**Driver Side tube packed using "Green" color foam sheet. Passenger Side tube packed using "White" color foam sheet**

No.	Parts Identification
1	Passenger / Right 'Rear' Bracket marked "PR"
2	Driver / Left 'Rear' Bracket marked "DR"
3	Passenger / Right 'Center' Bracket marked "PC"
4	Driver / Left 'Center' Bracket marked "DC"
5	Passenger / Right 'Front' Bracket marked "PF"
6	Driver / Left 'Front' Bracket marked "DF"

### Note:

- This guide is to identify the parts and not a reference for part count.
- For part count, refer Parts List.
- Product / Bracket image is representative and actual design may vary.

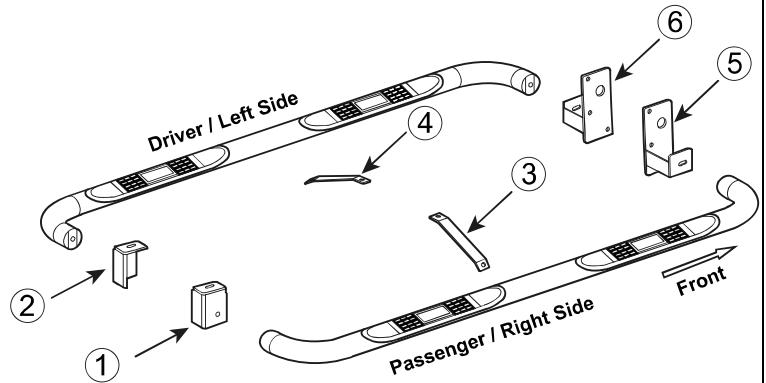

## PRODUCT CARE

- Periodically check the product to ensure all fasteners are tight and components are intact.
- Regular waxing is recommended to protect the finish of the product.
- **Use ONLY Non-Abrasive automotive wax.** Use of any soap, polish or wax that contains an abrasive is detrimental and can scratch the finish leading to corrosion.
- Aluminum polish may be used to polish small scratches and scuffs for **Stainless Steel finish.**
- Mild soap may be used to clean the product for both **Stainless Steel and Black finish.**

## FAQ's

### 1. Hardware's are not of correct size.

*In GMC / Chevrolet truck model 2006 & up, customer needs to reuse the factory body bolts to install the bracket. If your vehicle is not GMC / Chevrolet 2006 & up, ensure that holes are not partially covered with any plastic grommet or rust? If it is, remove the plastic grommet & rust from the thread holes & re-try the installation.*

### 2. Mounting Bracket are not getting Installed properly.

*In some cases Illustration images shown in Installation manual may not be the exactly same as per actual vehicle images ,also if Driver / Passenger side mounting brackets are very identical in the design, suggest referring Parts Identification guide to avoid fitment issue.*

### 3. Products are thumping / rattling after installation.

*Ensure that all required mounting brackets / hardware's are installed & tighten correctly. Suggest using white lithium / regular grease between the metal to metal contact surfaces.*

### 4. Side Bar is not aligning with vehicle / Step Pads are not aligning with vehicle doors.

*Side bar may be interchanged or mounting brackets are not installed at the correct position in the vehicle. Refer Parts identification guide.*

### 5. Missing / Excess Hardware.

*Recheck hardware count as per the part list.*

### 6. Product not installing properly.

*Ensure make model year, cab length and bed size of your vehicle is listed in the application. All installation steps are followed correctly.*