



4" Oval Nerf Bar

Part No. A1503S/B



Fits: 2007 - 2009
2007 - 2015
2007 - 2010
2007 - Current

Buick Enclave
GMC Acadia (Excl. Denali)
Saturn Outlook
Chevy Traverse

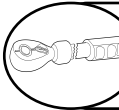

REMOVE CONTENTS FROM BOX. VERIFY ALL PARTS ARE PRESENT.

READ INSTRUCTIONS CAREFULLY BEFORE STARTING INSTALLATION.

DO NOT OVER TORQUE. STANDARD OPERATING LOAD FOR TIGHTEN BODY MOUNT NUTS & BOLTS VARIES FROM 45 TO 65 FOOT POUND.



60-180 min



Cutting Not Required



Drilling Not Required

PARTS LIST:

| Qty | Part Description | Qty | Part Description |
|-----|---|-----|--------------------------------------|
| 1 | Driver/Left Sidebar | 6 | 12mm Lock Washers |
| 1 | Passenger/Right Sidebar | 6 | 12mm ID x 32mm OD x 3mm Flat Washers |
| 1 | Driver/Left Front Mounting Bracket | 6 | 12mm Hex Nuts |
| 1 | Passenger/Right Front Mounting Bracket | 4 | 10mm Lock Washers |
| 1 | Driver/Left Rear Mounting Bracket | 4 | 10mm x 27mm OD x 3mm Flat Washers |
| 1 | Passenger/Right Rear Mounting Bracket | 4 | 10mm Hex Nuts |
| 2 | "Z" Brackets W/Welded 8mm Hex Nuts | 12 | 8-1.25mm x 25mm Hex Bolts |
| 6 | 12-1.75mm x 45mm Bolt Plates | 12 | 8mm Lock Washers |
| 4 | 10-1.5mm x 35mm Button Head Bolt Plates | 10 | 8mm ID x 24mm OD x 2mm Flat Washers |
| 6 | 12mm Square Washers | | |

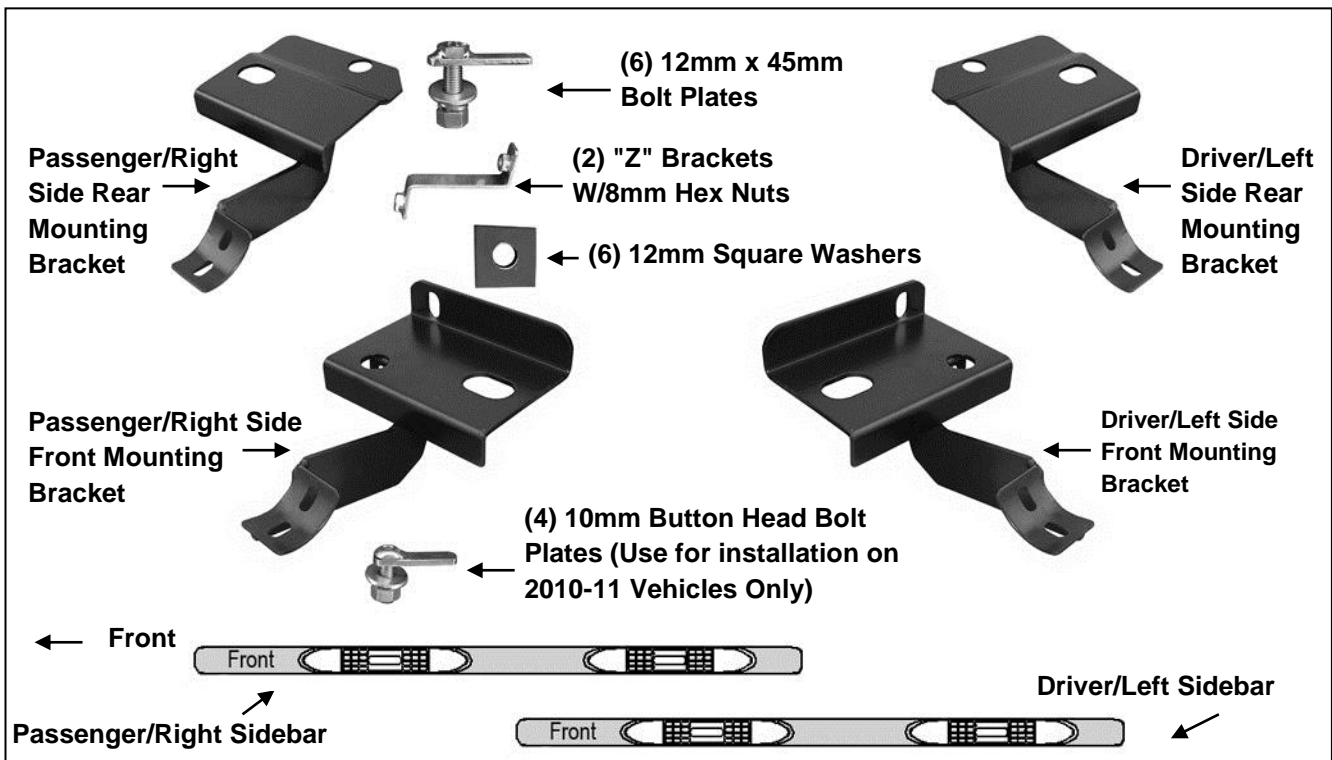

INSTALLATION PROCEDURE:

1. Start installation on the passenger side and locate the factory holes in the bottom and side of the floor panel towards the front of the vehicle.
 - a. **On 2007-09 Vehicles:** There is an oval hole and a round hole on the bottom of the floor panel and a round hole on the side of the floor panel. Insert (1) 12mm x 45mm Bolt Plate into the oval hole and turn the Bolt Plate 90-degees so that the plate is across opening, (**Figures 1 & 3B**).
 - b. **On 2010-11 Vehicles:** There are two round holes on the bottom of the floor panel, (one centered, one offset toward the pinch weld), and one round hole on the side of the floor panel. Insert (1) 10mm x 35mm Button Head Bolt Plate into the round hole in the center of the floor panel (**Figures 2 & 4B**). Make sure that the plate is supported across the hole in the floor panel.
2. Next, select (1) 8mm "Z" Bracket, (**Figure 1B**). Insert the end with the hex nut welded onto the outside of the Bracket into the round hole in the bottom of the floor panel. Maneuver the "Z" Bracket through the inside of the floor panel and line it up to the hole in the side of the floor panel, (**Figures 1A, 2 & 6**).
3. Position the passenger side front Mounting Bracket up to the vehicle and over the previously installed Bolt Plate and "Z" Bracket. **NOTE:** The hole pattern on the Mounting Bracket will match up with the hole pattern on the floor panel. Bolt the Mounting Bracket to the Bolt Plate using the included hardware.
 - a. **On 07-09 Vehicles:** Use (1) 12mm Square Washer, (1) 12mm Lock Washer and (1) 12mm Hex Nut to secure the Bracket to the Bolt Plate, (**Figure 3A**). Do not tighten hardware at this time.
 - b. **On 2010-11 Vehicles:** Use (1) 12mm Square Washer, (1) 10mm Flat Washer, (1) 10mm Lock Washer and (1) 10mm Hex Nut to secure the Bracket to the 10mm Bolt Plate, (**Figure 4A**). Do not tighten hardware at this time.

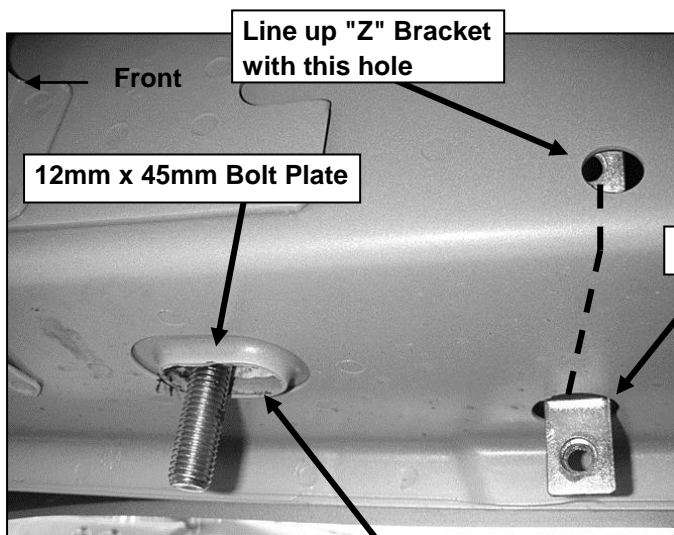

(Fig 1A) 07-09 Model Pictured-Note Oval Hole

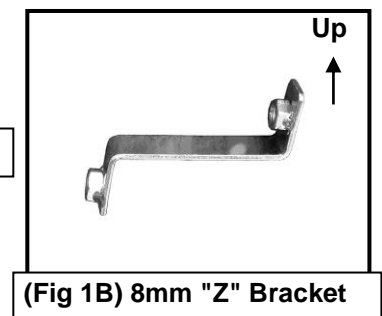

(Fig 1B) 8mm "Z" Bracket

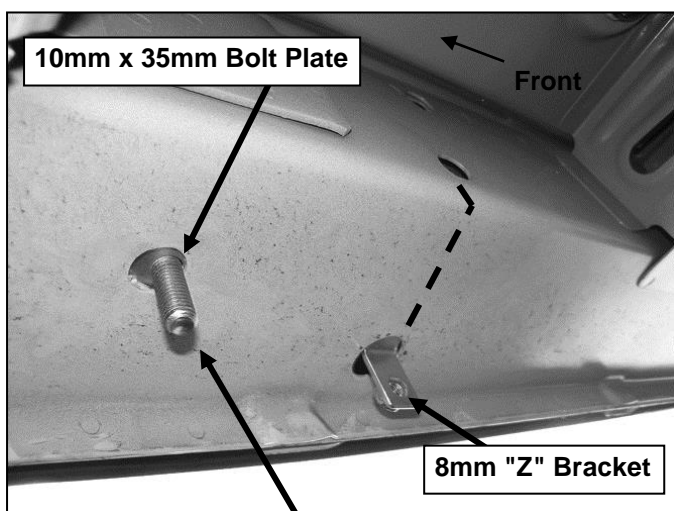

(Fig 2) 2010-11 Model Pictured-Note Round Hole

12mm x 45mm Bolt Plate
12mm Square Washer
12mm Lock Washer
12mm Hex Nut

8mm x 25mm Hex Bolt
8mm Lock Washer
8mm Flat Washer

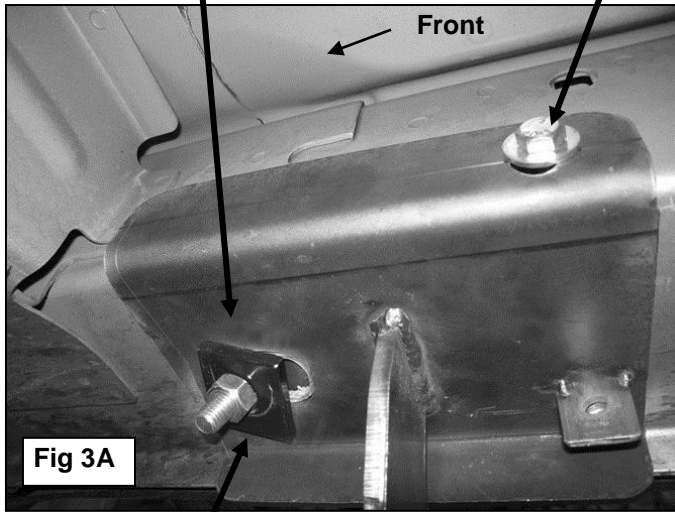

Fig 3A

10mm x 35mm Bolt Plate
12mm Square Washer
10mm Flat Washer
10mm Lock Washer
10mm Hex Nut

8mm x 25mm Hex Bolt
8mm Lock Washer
8mm Flat Washer

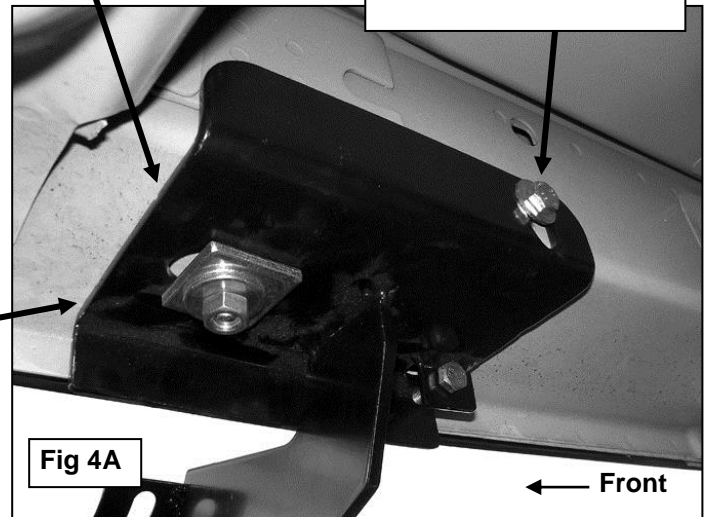

Fig 4A

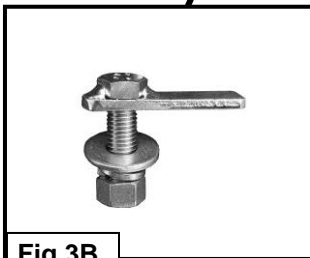

Fig 3B



Fig 4B

4. Insert (1) 8mm x 25mm Hex Bolt, (1) 8mm Lock Washer, and (1) 8mm Flat Washer through the Mounting Bracket, the side of the floor panel and into the nut on the "Z" Bracket, (Figures 3 & 4). Attach the remaining end of the "Z" Bracket to the tab on the bottom of the Mounting Bracket using the included (1) 8mm x 25mm Hex Bolt and (1) 8mm Lock Washer, (Figures 4 - 6). Snug but do not fully tighten hardware at this time.

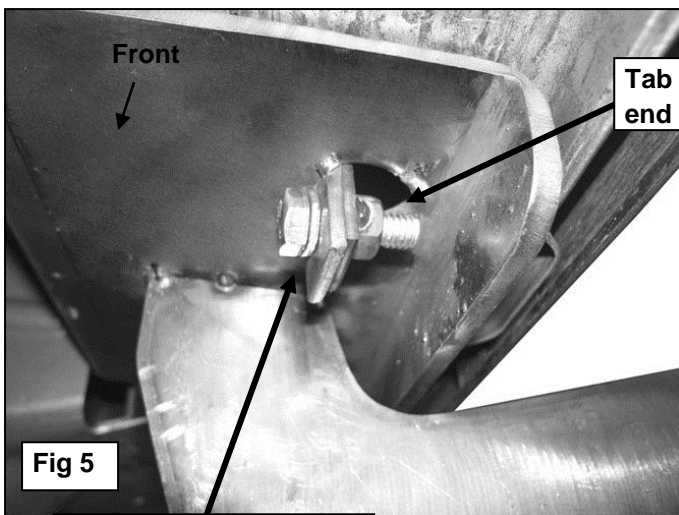
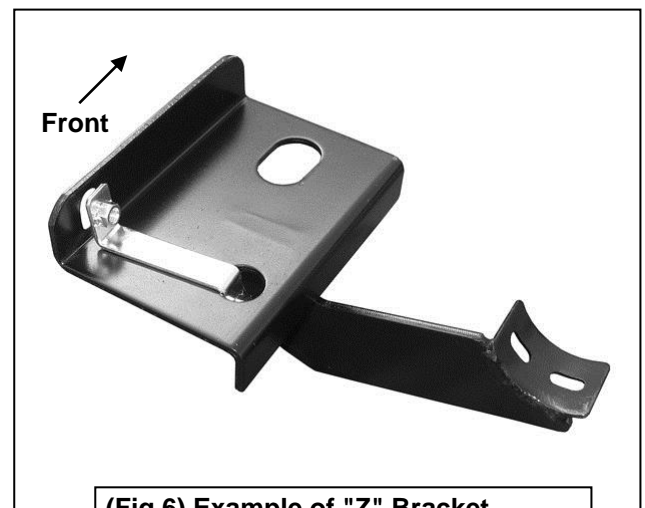

Fig 5

8mm x 25mm Hex Bolt
8mm Lock Washer

Tab with 8mm nut on
end of "Z" Bracket



(Fig 6) Example of "Z" Bracket
installation-most of Bracket installs
inside body panel and is not visible

5. Move toward the rear of the vehicle and locate the round or oval hole centered in the bottom of the floor panel as described in **Step 2, (Figures 7 & 8)**.
 - a. **07-09** vehicles are equipped with an oval hole in the center of the floor panel as described in **Step 2a**. Insert (1) 12mm x 45mm Bolt Plate into the oval hole in the center of the floor panel and turn 90-degees across the oval hole, (**Figure 7**).
 - b. **2010-11** vehicles are equipped with a round hole in the center of the floor panel as described in **Step 2b**. Insert (1) 10mm x 35mm Bolt Plate into the round hole in the center of the floor panel, (**Figure 8**).



12mm x 45mm Bolt Plate

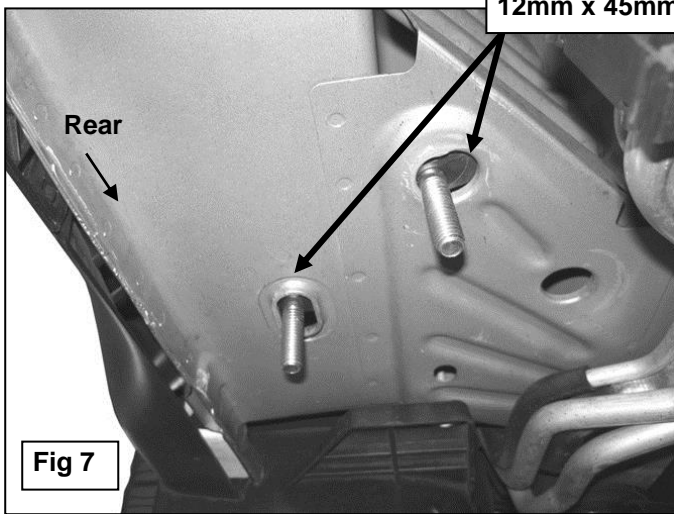

Fig 7

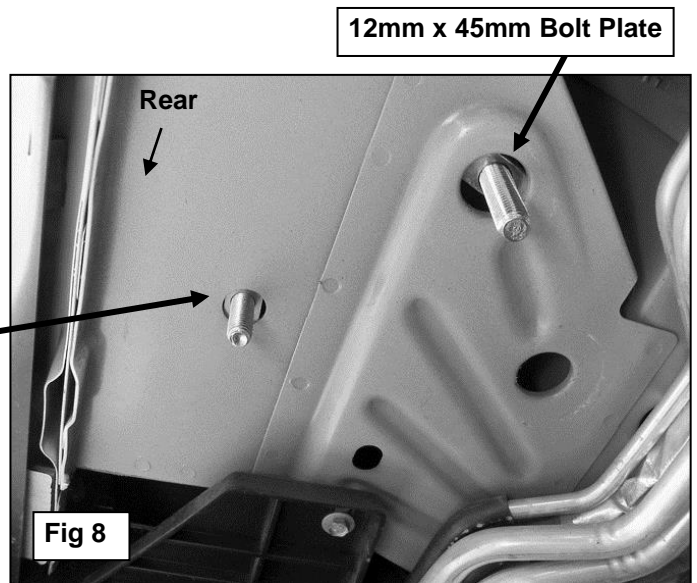

Fig 8



10mm x 35mm Bolt Plate

6. Next, locate the large hole slightly in toward the center of the vehicle from the previously installed Bolt Plate. **NOTE:** Use the passenger side Rear Bracket to determine the correct mounting hole to use. Insert (1) 12mm x 45mm Bolt Plate into the factory hole, (**Figures 7 & 8**). **NOTE:** Do not center the Bolt Plate in the hole, the shorter end of the Bolt Plate should be pushed to one side of the factory hole in order to fully engage.

7. Hold the passenger side Rear Mounting Bracket up to the vehicle and over the previously inserted Bolt Plates. Secure Mounting Bracket to the Bolt Plates using the included hardware.
 - a. **On 07-09 Vehicles:** Use (1) 12mm Square Washer, (1) 12mm Lock Washer and (1) 12mm Hex Nut to secure the Bracket to the Bolt Plate in the oval hole, **(Figure 9)**. Use (1) 12mm Flat Washer, (1) 12mm Lock Washer and (1) 12mm Hex Nut to secure the Bracket to the Bolt Plate in the round hole. Do not tighten hardware at this time.
 - b. **On 2010-11 Vehicles:** Use (1) 12mm Square Washer, (1) 10mm Flat Washer, (1) 10mm Lock Washer and (1) 10mm Hex Nut to secure the Bracket to the 10mm Bolt Plate in center of the floor panel, **(Figure 10)**. Use (1) 12mm Flat Washer, (1) 12mm Lock Washer and (1) 12mm Hex Nut to secure the Bracket to the Bolt Plate in the round hole. Do not tighten hardware at this time.

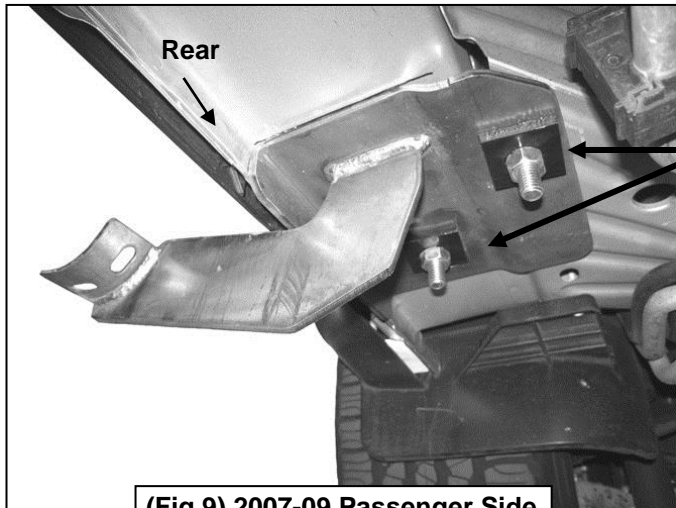

(Fig 9) 2007-09 Passenger Side Rear Installation Pictured

12mm x 45mm Bolt Plate
12mm Square Washer
12mm Lock Washer
12mm Hex Nut

10mm x 35mm Bolt Plate
12mm Square Washer
10mm Flat Washer
10mm Lock Washer
10mm Hex Nut

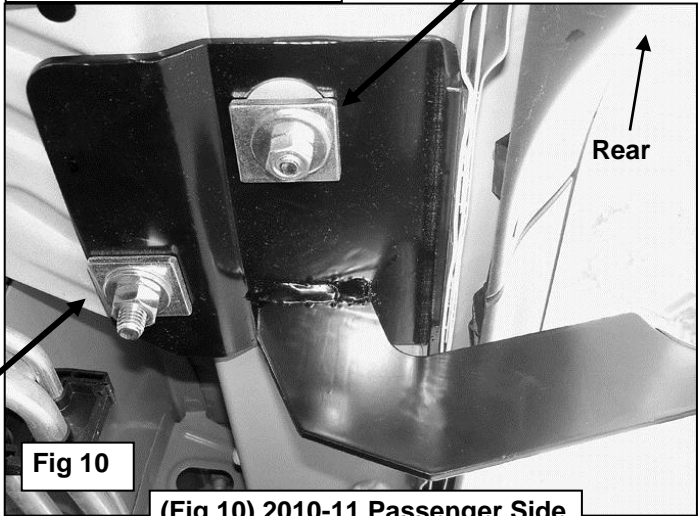

Fig 10

(Fig 10) 2010-11 Passenger Side Rear Installation Pictured

8. Carefully position the passenger Sidebar onto the Mounting Brackets. Bolt the Sidebar to the Mounting Brackets with the included (4) 8mm x 25mm Hex Bolts, (4) 8mm Lock Washers and (4) 8mm Flat Washers, **(Figure 11)**.
9. Level and adjust the Sidebar properly and tighten all hardware at this time. **IMPORTANT!** Do not move the Mounting Brackets too much when adjusting the Sidebar; this may cause Bolt Plates to disengage from the factory holes.
10. Repeat Steps 2 – 10 for driver Sidebar installation.
11. Do periodic inspections to the installation to make sure that all hardware is secure and tight.

8mm x 25mm Hex Bolt
8mm Lock Washer
8mm Flat Washer

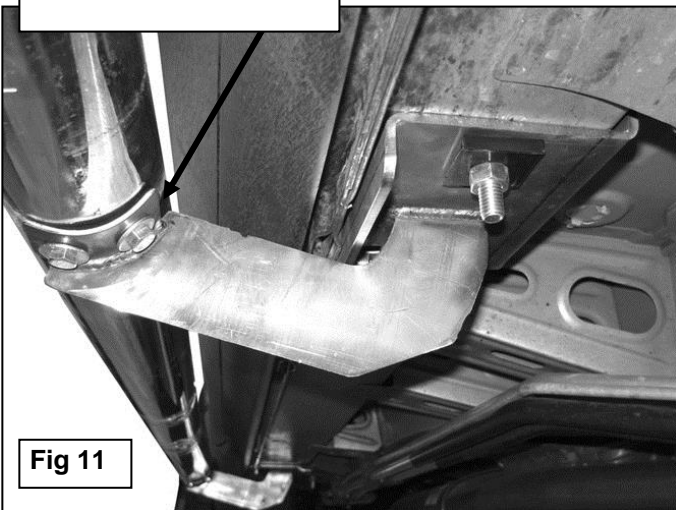

Fig 11



Installation Complete

| No. | Parts Identification |
|-----|--|
| 1 | Passenger / Right 'Rear' Bracket marked "PR" |
| 2 | Driver / Left 'Rear' Bracket marked "DR" |
| 3 | Passenger / Right 'Center' Bracket marked "PC" |
| 4 | Driver / Left 'Center' Bracket marked "DC" |
| 5 | Passenger / Right 'Front' Bracket marked "PF" |
| 6 | Driver / Left 'Front' Bracket marked "DF" |

Note:

- > This guide is to identify the parts and not a reference for part count.
- > For part count, refer Parts List.
- > Product / Bracket image is representative and actual design may vary.

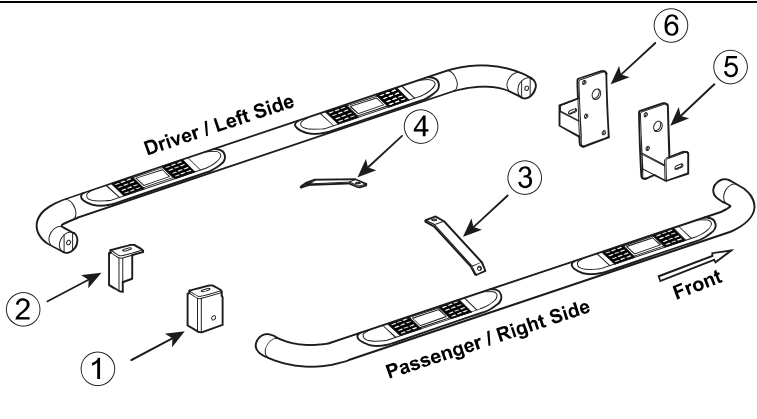

PRODUCT CARE

- Periodically check the product to ensure all fasteners are tight and components are intact.
- Regular waxing is recommended to protect the finish of the product.
- **Use ONLY Non-Abrasive automotive wax.** Use of any soap, polish or wax that contains an abrasive is detrimental and can scratch the finish leading to corrosion.
- Aluminum polish may be used to polish small scratches and scuffs for **Stainless Steel finish.**
- Mild soap may be used to clean the product for both **Stainless Steel and Black finish.**

FAQ's

- 1. Hardware's are not of correct size.**
In GMC / Chevrolet truck model 2006 & up, customer needs to reuse the factory body bolts to install the bracket. If your vehicle is not GMC / Chevrolet 2006 & up, ensure that holes are not partially covered with any plastic grommet or rust? If it is, remove the plastic grommet & rust from the thread holes & re-try the installation.
- 2. Mounting Bracket are not getting Installed properly.**
In some cases Illustration images shown in Installation manual may not be the exactly same as per actual vehicle images ,also if Driver / Passenger side mounting brackets are very identical in the design, suggest referring Parts Identification guide to avoid fitment issue.
- 3. Products are thumping / rattling after installation.**
Ensure that all required mounting brackets / hardware's are installed & tighten correctly. Suggest using white lithium / regular grease between the metal to metal contact surfaces.
- 4. Side Bar is not aligning with vehicle / Step Pads are not aligning with vehicle doors.**
Side bar may be interchanged or mounting brackets are not installed at the correct position in the vehicle. Refer Parts identification guide.
- 5. Missing / Excess Hardware.**
Recheck hardware count as per the part list.
- 6. Product not installing properly.**
Ensure make model year, cab length and bed size of your vehicle is listed in the application. All installation steps are followed correctly.

Check out these other TrailFX Products!!



Keystone Automotive Operations Inc. (KAO) warrants this product to be free of defects in material and workmanship at the time of purchase by the original retail consumer. KAO disclaims any other warranties, express or implied, including the warranty of fitness for a particular purpose or an intended use. If the product is found to be defective, KAO may replace or repair the product at our option, when the product is returned prepaid, with proof of purchase. Alteration to, improper installation, or misuse of this product voids the warranty. KAO's liability is limited to repair or replacement of products found to be defective, and specifically excludes liability for any incidental or consequential loss or damage.