

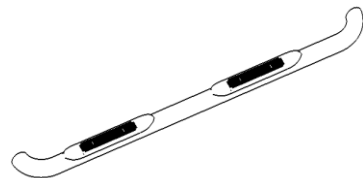

4" Oval Nerf Bar

Part No. A1013S/B



Fits: **Current Dodge Ram 1500 Quad Cab**



Including Diesel models with DEF tanks



60-180 min



Cutting is not Required



Drilling is not Required



REMOVE CONTENTS FROM BOX. VERIFY ALL PARTS ARE PRESENT.



READ INSTRUCTIONS CAREFULLY BEFORE STARTING INSTALLATION.

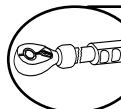

DO NOT OVER TORQUE. STANDARD OPERATING LOAD FOR TIGHTEN BODY MOUNT NUTS & BOLTS VARIES FROM 45 TO 65 FOOT POUND.

PARTS LIST:

Qty	Part Description	Qty	Part Description
2	4" Oval 90 deg. Bent End Sidebars	1	Driver/left side Rear Support Bracket
1	Driver/left side Front Mounting Bracket	1	Passenger/right side Rear Support Bracket
1	Passenger/right side Front Mounting Bracket	4	1/2" x 2" Hex Bolts
1	Driver/left side Rear Mounting Bracket	4	1/2" x 1-1/2" x 1/8" Flat Washers
1	Passenger/right side Rear Mounting Bracket	4	1/2" Lock Washers
1	Driver/left side Front Support Bracket	12	8-1.25mm Nylon Lock Nuts
1	Passenger/right side Front Support Bracket	12	8mm x 24mm x 2mm Flat Washers

Passenger/right side Rear Bracket

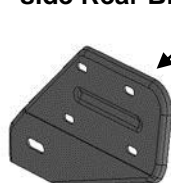

Passenger/right side Rear Support Bracket

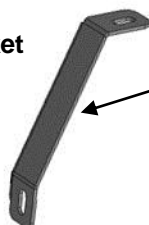

Driver/left side Rear Support Bracket

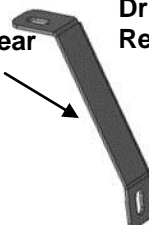

Driver/left side Rear Bracket



NOTE: The Front Support Brackets are shorter than the Rear Support Brackets.

Passenger/right side Front Support Bracket



Driver/left side Front Support Bracket



Passenger/right side Front Bracket

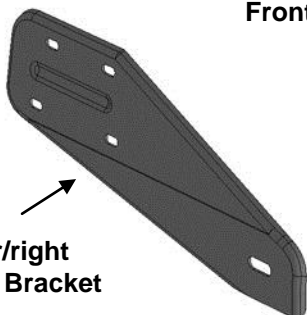

Driver/left side Front Bracket

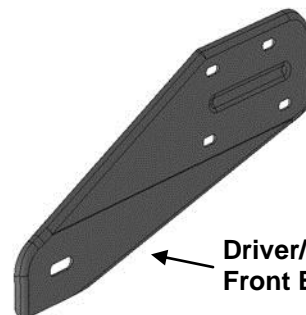

PROCEDURE:

REMOVE CONTENTS FROM BOX. VERIFY ALL PARTS ARE PRESENT. READ INSTRUCTIONS CAREFULLY BEFORE STARTING INSTALLATION. ASSISTANCE IS RECOMMENDED.

1. Start the installation under the driver/left side of the vehicle. Locate the front (3) factory studs along the inner side of the body panel, **(Figure 1)**. **IMPORTANT:** Use a wire brush or thread die to remove paint buildup on the threaded studs before continuing with installation.

2. Select the driver/left Front Mounting Bracket. Place the Bracket over the studs with the flat side against the body panel. Attach the Bracket to the (3) factory studs with (3) 8mm Flat Washers and (3) 8mm Nylon Lock Nuts, **(Figures 2 & 3)**. Leave Bracket loose at this time.
3. Locate the front body mount next to the installed Bracket, **(Figure 4)**. Remove the body bolt and washer, **(Figure 5)**. **NOTE:** Clean threads on body bolt to remove paint buildup before reinstalling. Select the driver/left Front Support Bracket, **(Figure 6)**. Reuse the factory body bolt and washer to attach the upper slot in the Support Bracket to the body mount. **(Figure 7)**.
4. Move to the rear mounting location, **(Figure 8)**. Repeat **Steps 1—3** to attach the driver/left Rear Mounting Bracket and Support Bracket, **(Figures 9 & 10)**.
5. Carefully unwrap and select (1) Sidebar. With assistance, line up the front end of the tube with the front Bracket, **(Figure 11)**. Attach the front end of the Sidebar to the Front Brackets with the included 1/2" Hex Bolt, 1/2" Lock Washer and 1/2" Flat Washer, **(Figures 11 & 12)**. Do not tighten hardware.
6. Move to the rear of the Sidebar and repeat **Step 5** to attach the Sidebar to the Brackets, **(Figure 13)**.
7. Level and adjust the Sidebar as necessary and fully tighten all hardware.
8. Repeat **Steps 1—7** for passenger/right Sidebar.
9. Do periodic inspections to the installation to make sure that all hardware is secure and tight.

Driver/left Side Installation Pictured

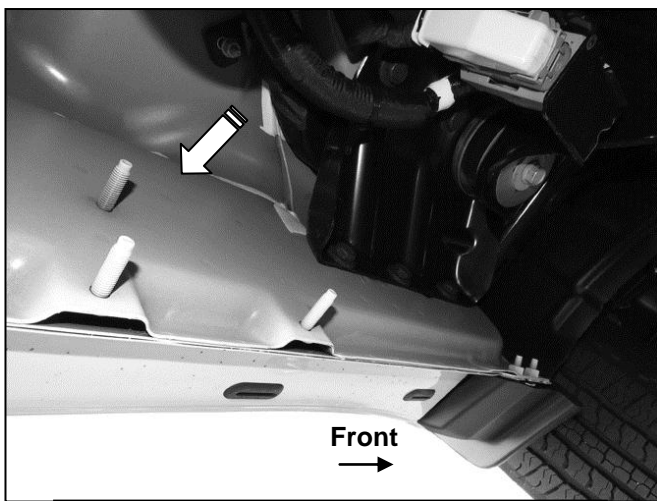

(Fig 1) Driver/left front mounting location

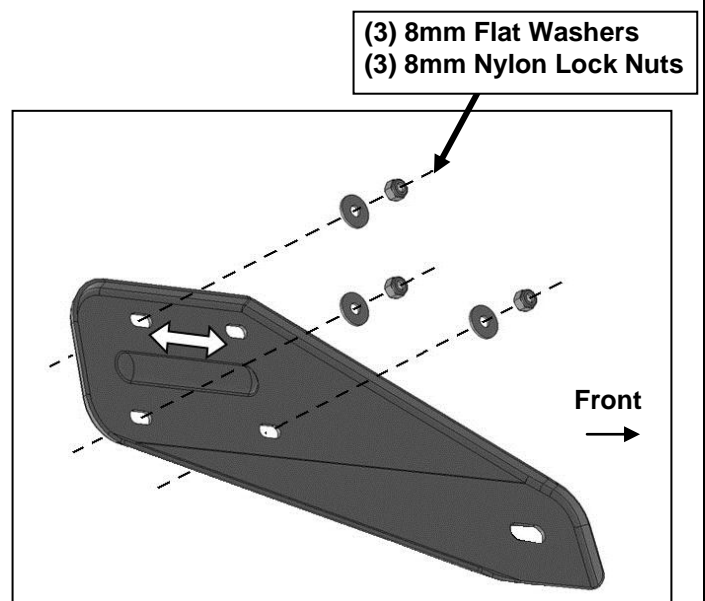

(Fig 2) Attach flat side of Driver/left Front Mounting Bracket to side of inner body panel

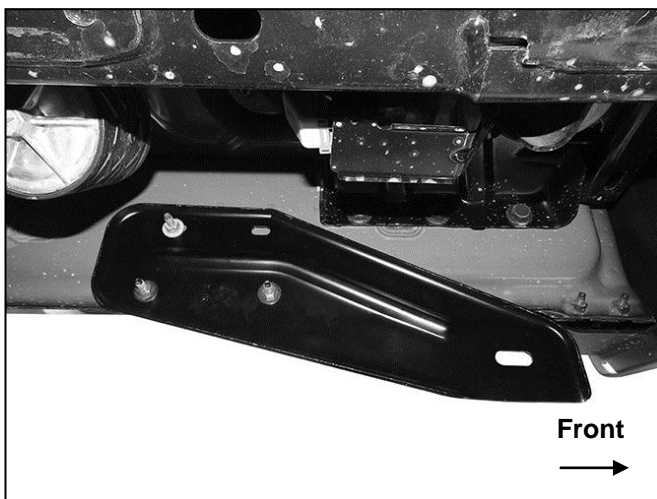

(Fig 3) Driver/left Front Bracket installed

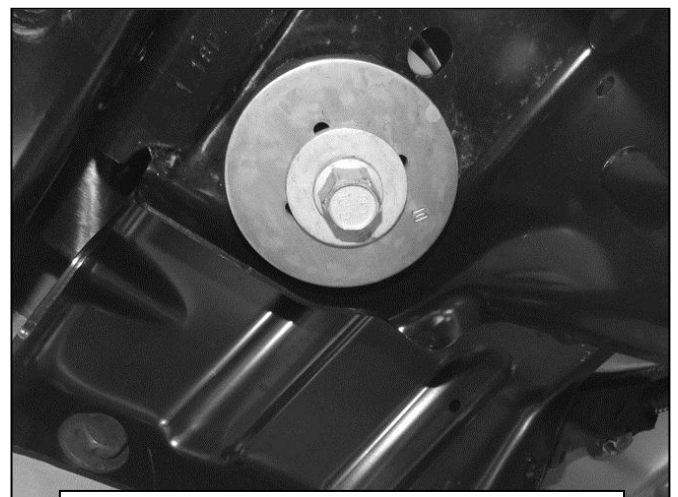

(Fig 4) Locate driver/left front body mount (passenger side pictured for example)

Driver/left Side Installation Pictured



(Fig 5) Remove factory body bolt

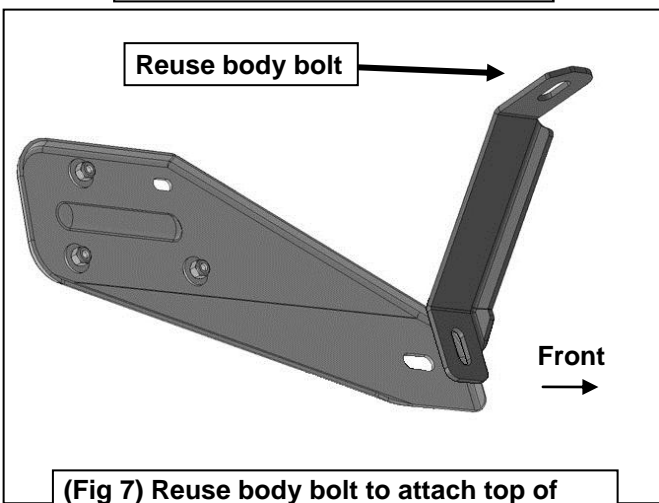

(Fig 7) Reuse body bolt to attach top of Support Bracket to body mount (Driver/left Front Support Bracket illustrated)

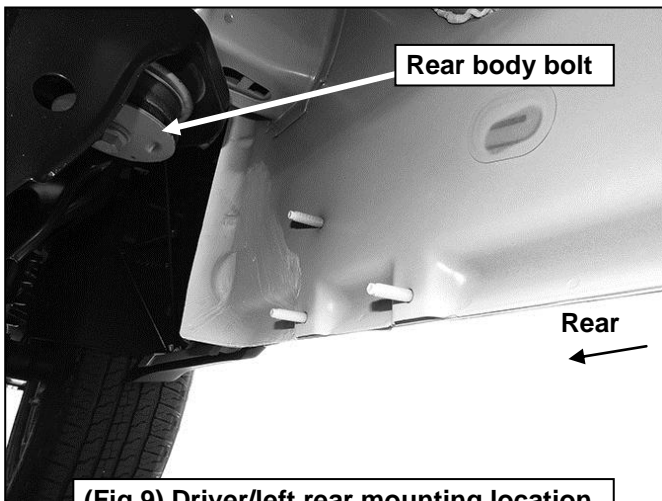

(Fig 9) Driver/left rear mounting location



(Fig 6) Driver/left Front and Rear Support Brackets. NOTE: Front Support Bracket (left) is shorter than the rear (right).



(Fig 8) Driver/left Front Support Bracket attached to body mount

Driver/left Side Installation Pictured

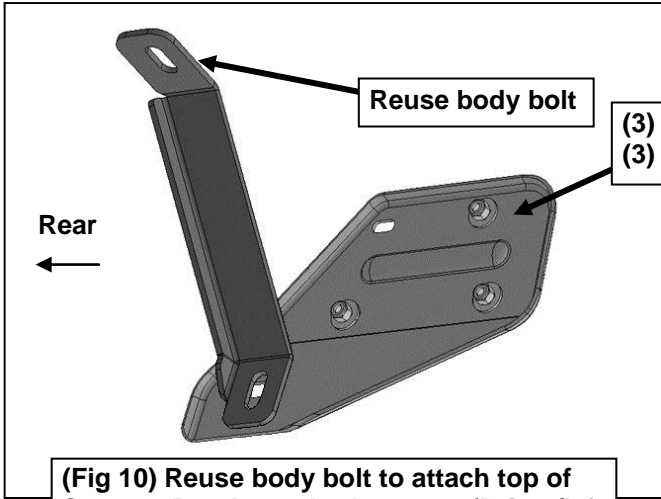

(Fig 10) Reuse body bolt to attach top of Support Bracket to body mount (Driver/left Rear Support Bracket illustrated)

NOTE: The Front Support Bracket is shorter than the Rear Support Bracket.

- (3) 8mm Flat Washers
- (3) 8mm Nylon Lock Nuts

- 1/2" x 2" Hex Bolt
- 1/2" Lock Washer
- 1/2" Flat Washer

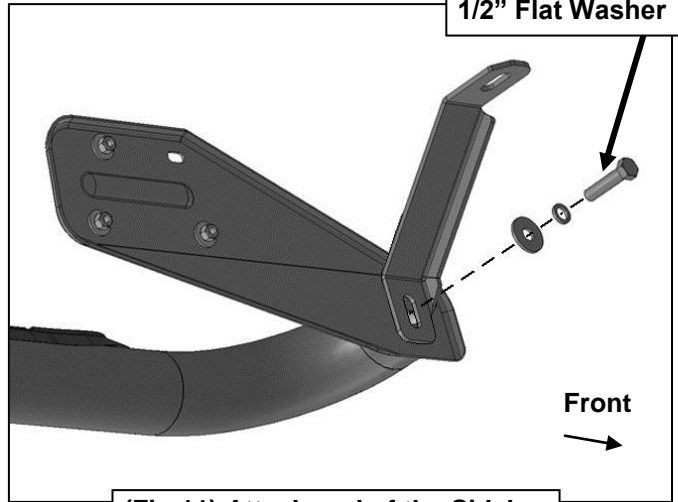

(Fig 11) Attach end of the Sidebar to the driver/left front Bracket

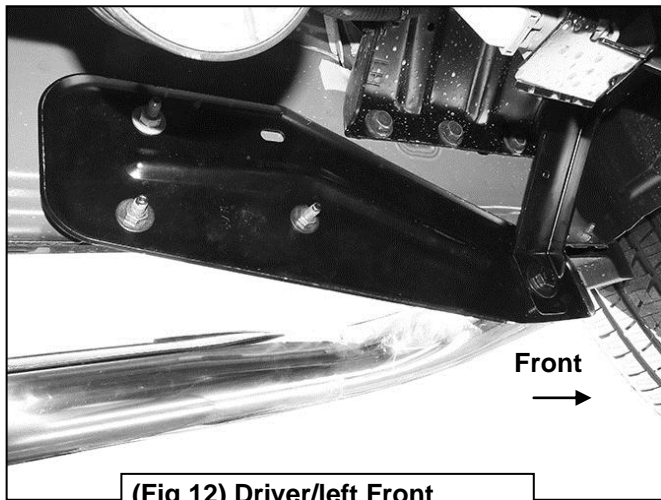

(Fig 12) Driver/left Front Brackets and Sidebar installed

- 1/2" x 2" Hex Bolt
- 1/2" Lock Washer
- 1/2" Flat Washer

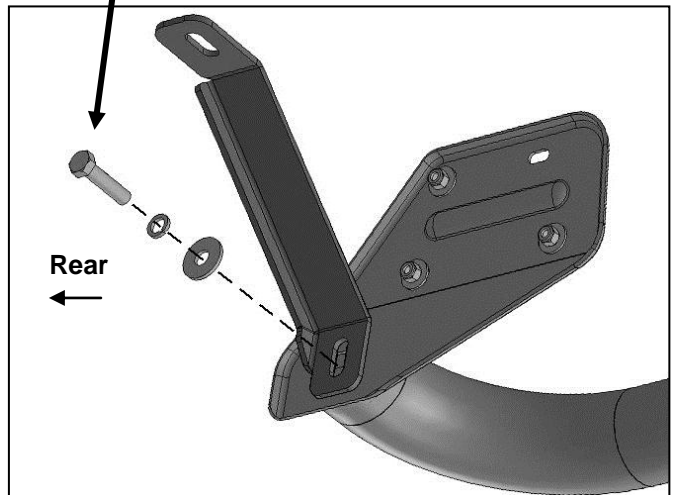

(Fig 13) Attach Sidebar to Driver/left Rear Brackets

PARTS IDENTIFICATION GUIDE

Driver Side tube packed using "Green" color foam sheet. Passenger Side tube packed using "White" color foam sheet

No.	Parts Identification
1	Passenger / Right 'Rear' Bracket marked "PR"
2	Driver / Left 'Rear' Bracket marked "DR"
3	Passenger / Right 'Center' Bracket marked "PC"
4	Driver / Left 'Center' Bracket marked "DC"
5	Passenger / Right 'Front' Bracket marked "PF"
6	Driver / Left 'Front' Bracket marked "DF"

Note:

- This guide is to identify the parts and not a reference for part count.
- For part count, refer Parts List.
- Product / Bracket image is representative and actual design may vary.

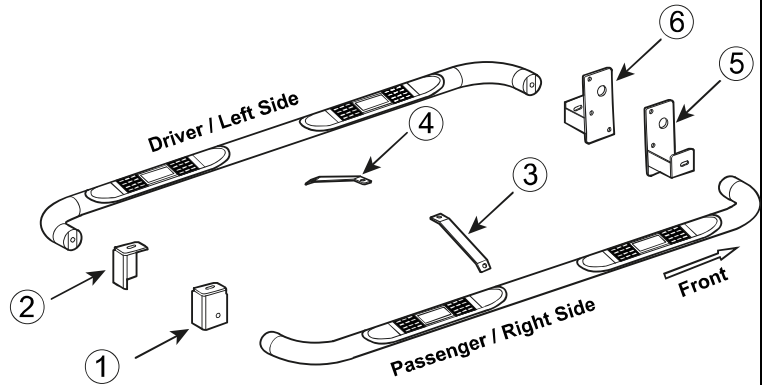

PRODUCT CARE

- Periodically check the product to ensure all fasteners are tight and components are intact.
- Regular waxing is recommended to protect the finish of the product.
- **Use ONLY Non-Abrasive automotive wax.** Use of any soap, polish or wax that contains an abrasive is detrimental and can scratch the finish leading to corrosion.
- Aluminum polish may be used to polish small scratches and scuffs for **Stainless Steel finish.**
- Mild soap may be used to clean the product for both **Stainless Steel and Black finish.**

FAQ's

1. Hardware's are not of correct size.

In GMC / Chevrolet truck model 2006 & up, customer needs to reuse the factory body bolts to install the bracket. If your vehicle is not GMC / Chevrolet 2006 & up, ensure that holes are not partially covered with any plastic grommet or rust? If it is, remove the plastic grommet & rust from the thread holes & re-try the installation.

2. Mounting Bracket are not getting Installed properly.

In some cases Illustration images shown in Installation manual may not be the exactly same as per actual vehicle images ,also if Driver / Passenger side mounting brackets are very identical in the design, suggest referring Parts Identification guide to avoid fitment issue.

3. Products are thumping / rattling after installation.

Ensure that all required mounting brackets / hardware's are installed & tighten correctly. Suggest using white lithium / regular grease between the metal to metal contact surfaces.

4. Side Bar is not aligning with vehicle / Step Pads are not aligning with vehicle doors.

Side bar may be interchanged or mounting brackets are not installed at the correct position in the vehicle. Refer Parts identification guide.

5. Missing / Excess Hardware.

Recheck hardware count as per the part list.

6. Product not installing properly.

Ensure make model year, cab length and bed size of your vehicle is listed in the application. All installation steps are followed correctly.

Check out these other TrailFX Products!!



BULL BAR



GRILLE GUARDS



BED RAILS

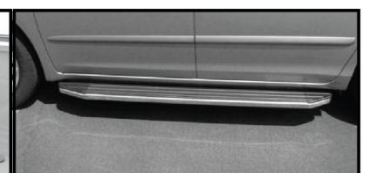

RUNNING BOARDS



RUNNING BOARDS



RUNNING BOARDS

free of defects in material and workmanship at the time of purchase by the implied, including the warranty of fitness for a particular purpose or an repair the product at our option, when the product is returned prepaid, of this product voids the warranty. KAO's liability is limited to repair or ability for any incidental or consequential loss or damage.