

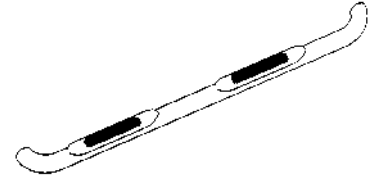

4" Oval Nerf Bar

Part No. A1012S/B



Fits: **Current Dodge Ram 1500 Crew Cab**



Including Diesel models with DEF tanks



60-180 min



Cutting is not Required



Drilling is not Required



REMOVE CONTENTS FROM BOX. VERIFY ALL PARTS ARE PRESENT.



READ INSTRUCTIONS CAREFULLY BEFORE STARTING INSTALLATION.

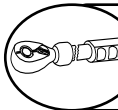

DO NOT OVER TORQUE. STANDARD OPERATING LOAD FOR TIGHTEN BODY MOUNT NUTS & BOLTS VARIES FROM **45 TO 65** FOOT POUND.

PARTS LIST:

Qty	Part Description	Qty	Part Description
1	Driver/left 4" Oval 90 deg. Bent End Sidebar	1	Passenger/right side Rear Support Bracket
1	Passenger/right 4" Oval 90 deg. Bent End Sidebar	4	1/2" x 2" Hex Bolts
2	Driver Front/ Passenger Rear Mounting Brackets	4	1/2" x 1-1/2" x 1/8" Flat Washers
2	Passenger Front/Driver Rear Mounting Brackets	4	1/2" Lock Washers
1	Driver/left side Front Support Bracket	12	8-1.25mm Nylon Lock Nuts
1	Passenger/right side Front Support Bracket	12	8mm x 24mm x 2mm Flat Washers
1	Driver/left side Rear Support Bracket		

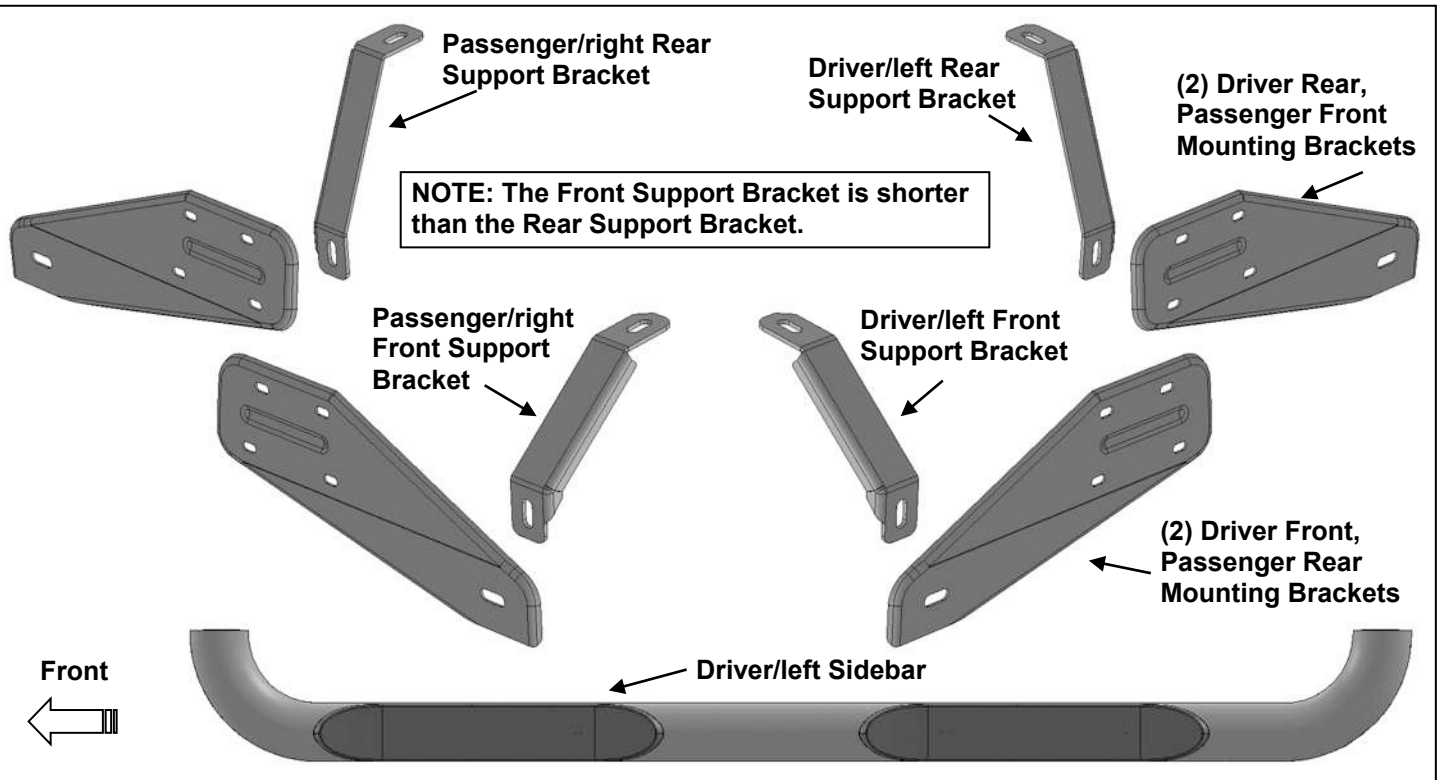

PROCEDURE:

REMOVE CONTENTS FROM BOX. VERIFY ALL PARTS ARE PRESENT. READ INSTRUCTIONS CAREFULLY BEFORE STARTING INSTALLATION. ASSISTANCE IS RECOMMENDED.

1. Start the installation under the driver/left side of the vehicle. Locate the front (3) factory studs along the inner side of the body panel, **(Figure 1)**. **IMPORTANT:** Use a wire brush or thread die to remove paint buildup from the threaded studs before continuing with installation.
2. Select (1) Driver/left Front Mounting Bracket, **(Figure 2)**. **NOTE:** Driver/left front and passenger/right rear Brackets are the same. Place the Bracket over the studs with the flat side against the body panel. Attach the Bracket to the (3) factory studs with (3) 8mm Flat Washers and (3) 8mm Nylon Lock Nuts, **(Figures 2 & 3)**. Leave Bracket loose at this time.
3. Locate the front body mount next to the installed Bracket, **(Figure 4)**. Remove the body bolt and washer, **(Figure 5)**. **NOTE:** Clean threads on body bolt to remove paint buildup before reinstalling.
4. Select the driver/left Front Support Bracket, **(Figure 6)**. Reuse the factory body bolt and washer to attach the upper slot in the Support Bracket to the body mount. **(Figures 7 & 8)**.
5. Move to the rear mounting location, **(Figure 9)**. Repeat **Steps 1—4** for Driver/left Rear Mounting Bracket and Driver/left Rear Support Bracket installation, **(Figures 10—12)**.
6. Carefully unwrap and select the Driver/left 3" Sidebar. Use the illustration above to help identify the correct Sidebar. With assistance, line up the front end of the tube with the front Bracket, **(Figure 13)**. Attach the front end of the Sidebar to the Front Brackets with the included 1/2" Hex Bolt, 1/2" Lock Washer and 1/2" Flat Washer, **(Figures 13 & 14)**. Do not tighten hardware.
7. Move to the rear of the Sidebar. Repeat **Step 6** to attach the Sidebar to the rear Brackets, **(Figures 15 & 16)**.
8. Level and adjust the Sidebar as necessary and fully tighten all hardware.
9. Repeat **Steps 1—8** for passenger/right Bracket and Sidebar installation.
10. Do periodic inspections to the installation to make sure that all hardware is secure and tight.

To protect your investment, wax this product after installing. Regular waxing is recommended to add a protective layer over the finish. Do not use any type of polish or wax that may contain abrasives that could damage the finish. Mild soap may be used also to clean the Sidebar.

Driver/left Side Installation Pictured

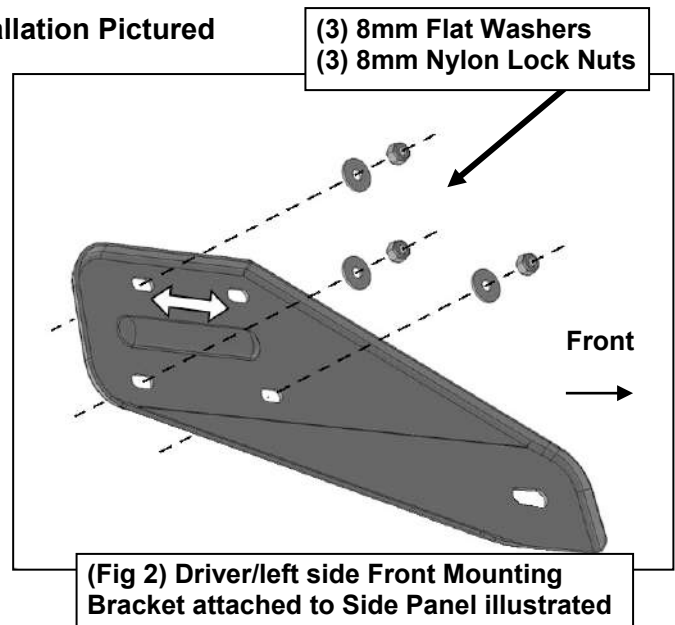
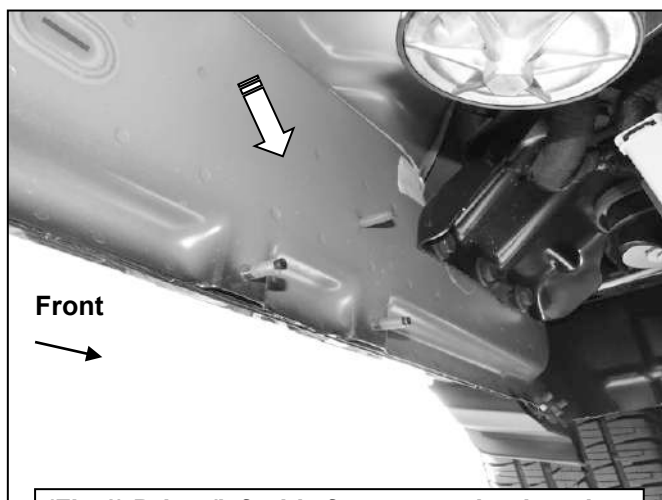

(3) 8mm Flat Washers
(3) 8mm Nylon Lock Nuts

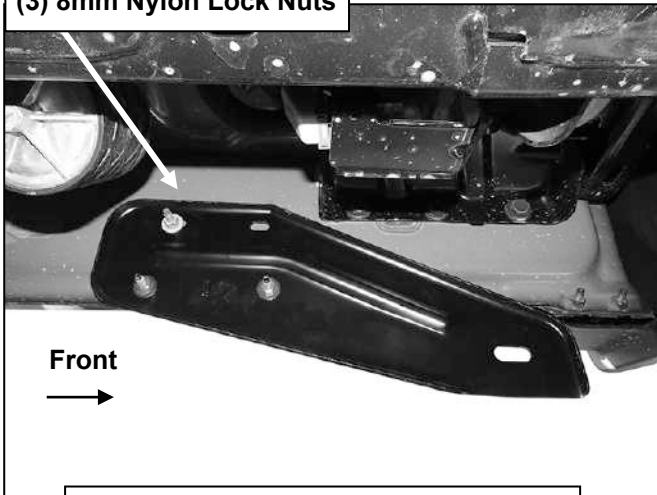

(Fig 3) Attach Bracket to the (3) studs

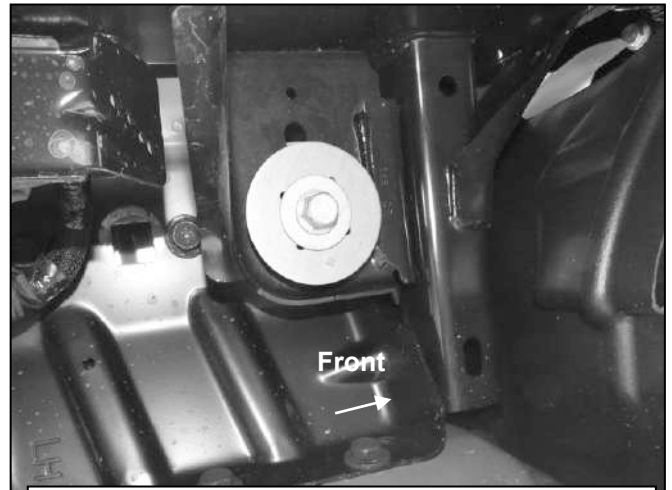

(Fig 4) Locate driver/left side front body mount

Driver/left Side Installation Pictured

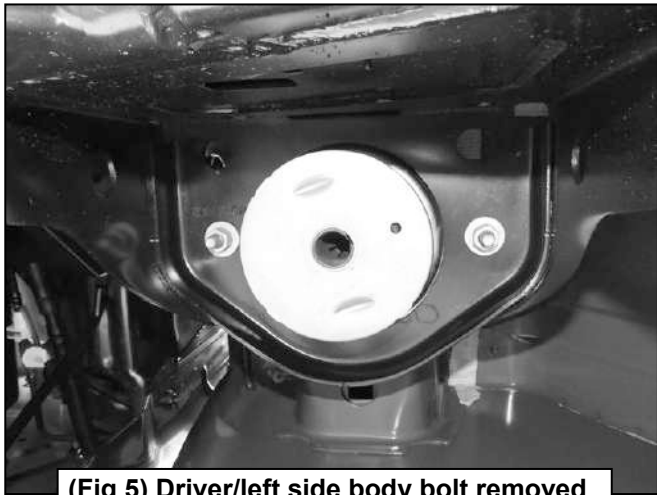

(Fig 5) Driver/left side body bolt removed

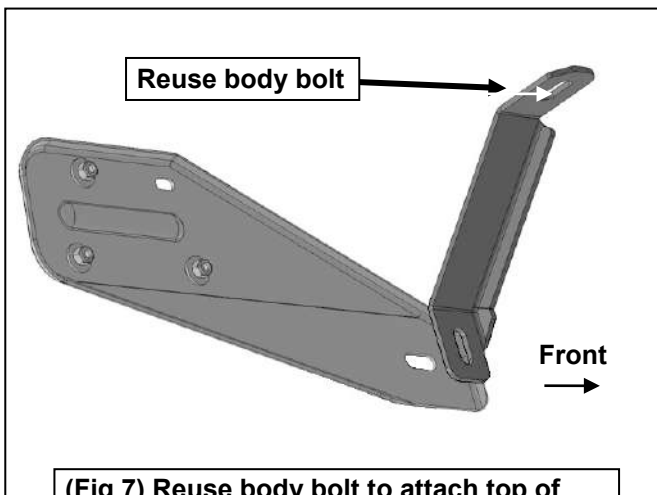

(Fig 7) Reuse body bolt to attach top of Support Bracket to body mount (Driver/left Front Support Bracket illustrated)



(Fig 6) Driver/left Front and Rear Support Brackets. NOTE: Front Support Bracket (left) is shorter than the rear (right).



(Fig 8) Driver/left Front Support Bracket attached to body mount

Driver/left Side Installation Pictured

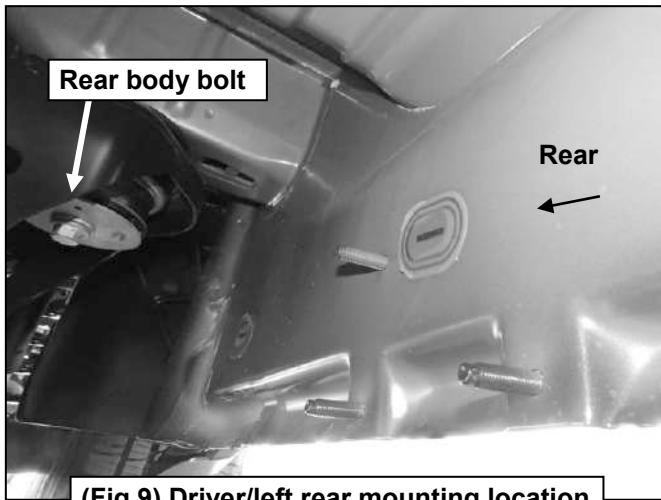

(Fig 9) Driver/left rear mounting location

**(3) 8mm Flat Washers
(3) 8mm Nylon Lock Nuts**

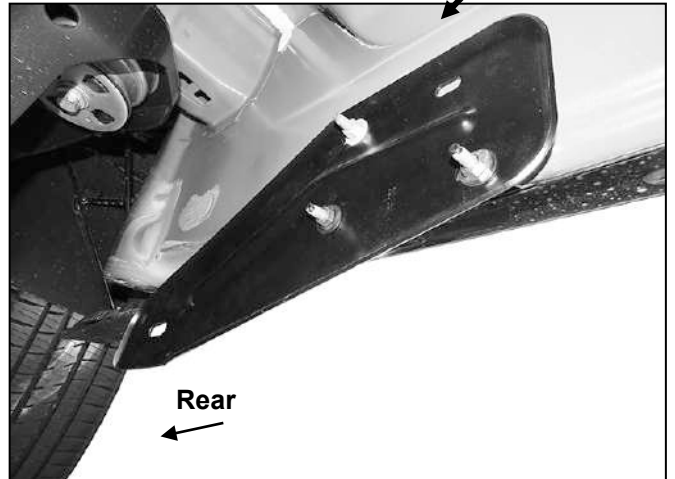

(Fig 10) Driver/left Rear Mounting Bracket installed

Reuse body bolt

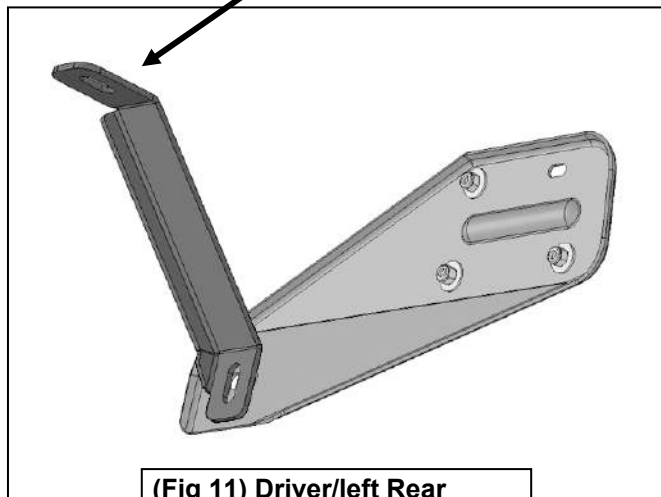

(Fig 11) Driver/left Rear Support Bracket illustrated

Reuse body bolt

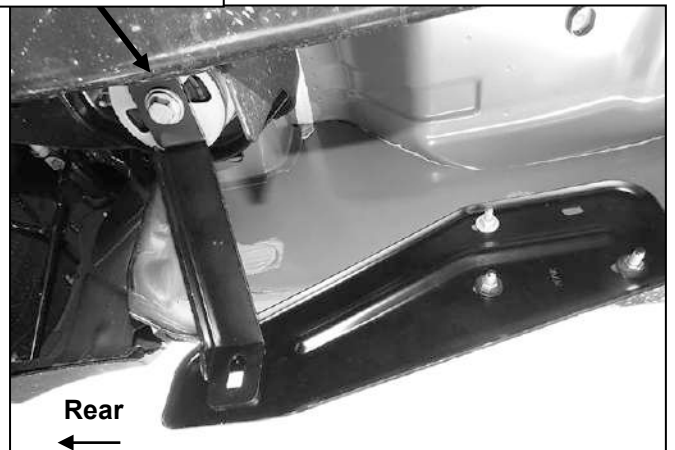

(Fig 12) Reuse body bolt to attach top of Support Bracket to body mount (Driver/left Rear Brackets pictured)

Driver/left Side Installation Pictured

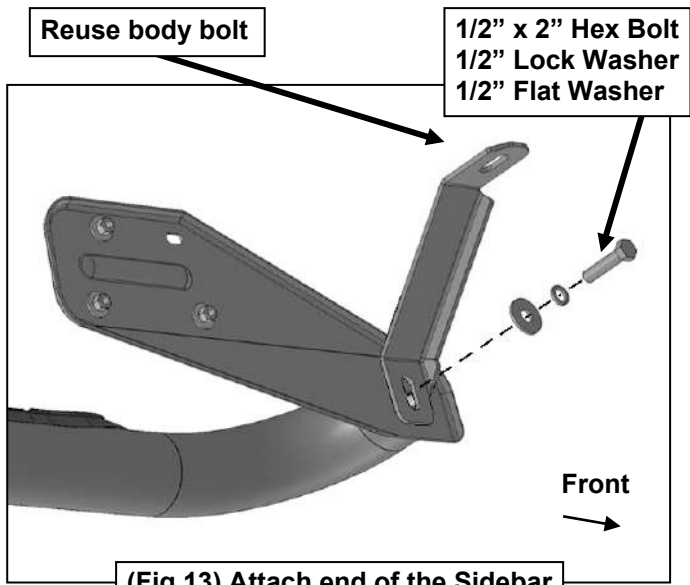

(Fig 13) Attach end of the Sidebar to the driver/left front Brackets

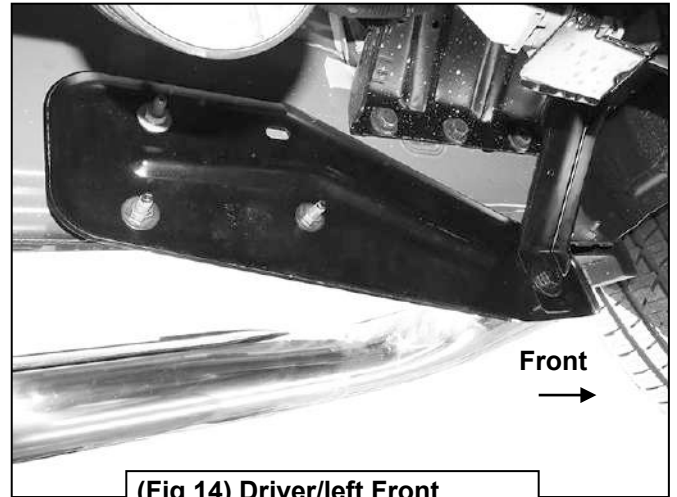

(Fig 14) Driver/left Front Brackets and Sidebar installed

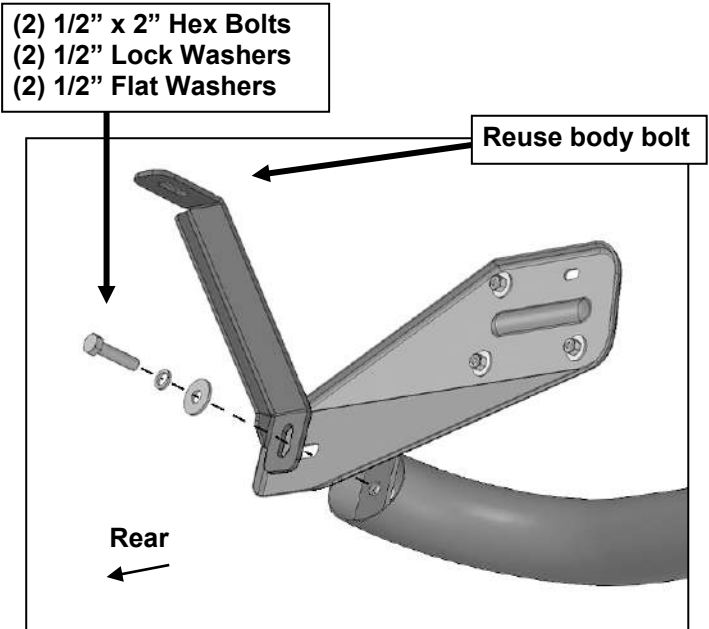

(Fig 15) Attach Sidebar to Driver/left Rear Brackets

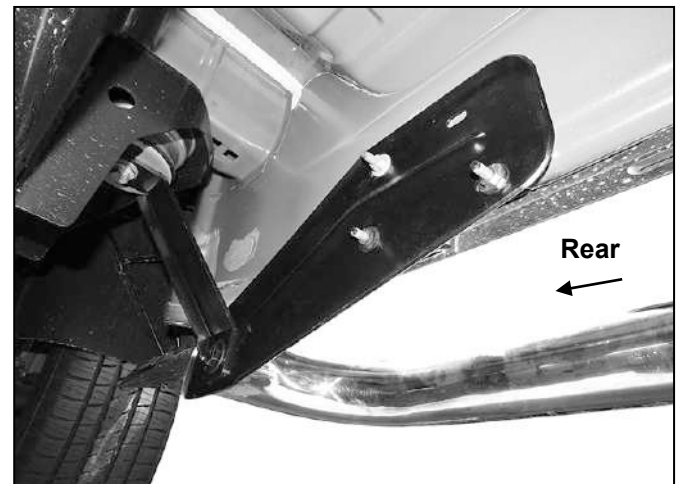

(Fig 16) Attach driver/left rear of Sidebar to Brackets

PARTS IDENTIFICATION GUIDE

Driver Side tube packed using "Green" color foam sheet. Passenger Side tube packed using "White" color foam sheet

No.	Parts Identification
1	Passenger / Right 'Rear' Bracket marked "PR"
2	Driver / Left 'Rear' Bracket marked "DR"
3	Passenger / Right 'Center' Bracket marked "PC"
4	Driver / Left 'Center' Bracket marked "DC"
5	Passenger / Right 'Front' Bracket marked "PF"
6	Driver / Left 'Front' Bracket marked "DF"

- Note:**
- This guide is to identify the parts and not a reference for part count.
 - For part count, refer Parts List.
 - Product / Bracket image is representative and actual design may vary.

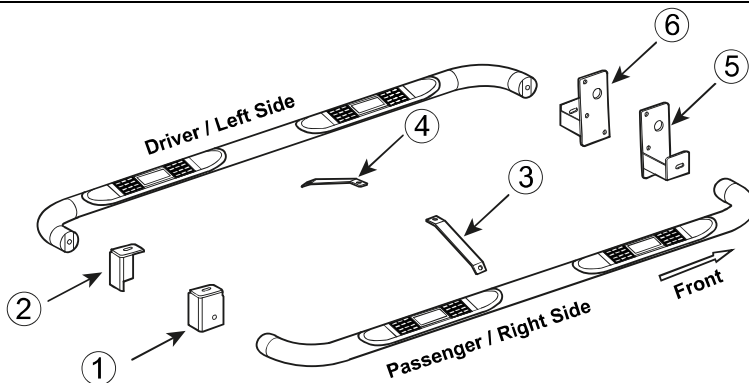

PRODUCT CARE

- Periodically check the product to ensure all fasteners are tight and components are intact.
- Regular waxing is recommended to protect the finish of the product.
- **Use ONLY Non-Abrasive automotive wax.** Use of any soap, polish or wax that contains an abrasive is detrimental and can scratch the finish leading to corrosion.
- Aluminum polish may be used to polish small scratches and scuffs for **Stainless Steel finish.**
- Mild soap may be used to clean the product for both **Stainless Steel and Black finish.**

FAQ's

1. Hardware's are not of correct size.

In GMC / Chevrolet truck model 2006 & up, customer needs to reuse the factory body bolts to install the bracket. If your vehicle is not GMC / Chevrolet 2006 & up, ensure that holes are not partially covered with any plastic grommet or rust? If it is, remove the plastic grommet & rust from the thread holes & re-try the installation.

2. Mounting Bracket are not getting Installed properly.

In some cases Illustration images shown in Installation manual may not be the exactly same as per actual vehicle images ,also if Driver / Passenger side mounting brackets are very identical in the design, suggest referring Parts Identification guide to avoid fitment issue.

3. Products are thumping / rattling after installation.

Ensure that all required mounting brackets / hardware's are installed & tighten correctly. Suggest using white lithium / regular grease between the metal to metal contact surfaces.

4. Side Bar is not aligning with vehicle / Step Pads are not aligning with vehicle doors.

Side bar may be interchanged or mounting brackets are not installed at the correct position in the vehicle. Refer Parts identification guide.

5. Missing / Excess Hardware.

Recheck hardware count as per the part list.

6. Product not installing properly.

Ensure make model year, cab length and bed size of your vehicle is listed in the application. All installation steps are followed correctly.

Check out these other TrailFX Products!!



BULL BAR



GRILLE GUARDS



BED RAILS



RUNNING BOARDS



RUNNING BOARDS



RUNNING BOARDS

Free of defects in material and workmanship at the time of purchase by the manufacturer, including the warranty of fitness for a particular purpose or an implied warranty, when the product is returned prepaid, this product voids the warranty. KAO's liability is limited to repair or replacement for any incidental or consequential loss or damage.