



# 3" Side Bar

Part No. A0056S /T



Fits: 2018-Current WRANGLER JL 2DR



60-180 min



Cutting Not Required



Drilling Not Required



REMOVE CONTENTS FROM BOX. VERIFY ALL PARTS ARE PRESENT.



READ INSTRUCTIONS CAREFULLY BEFORE STARTING INSTALLATION.

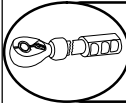

DO NOT OVER TORQUE. STANDARD OPERATING LOAD FOR TIGHTEN BODY MOUNT NUTS & BOLTS VARIES FROM 45 TO 65 FOOT POUND.

### PARTS LIST:

Qty	Part Description	Qty	Part Description
1	Driver/left side 3" Sidebar	4	10-1.5mm x 30mm Hex Bolts
1	Passenger/right side 3" Sidebar	8	10mm x 24mm x 2mm Flat Washers
1	Driver/left side Front Mounting Bracket	4	10-1.5mm Nylon Lock Nuts
1	Passenger/right side Front Mounting Bracket	8	8-1.25mm Combo Bolts
1	Driver/right side Rear Mounting Bracket	4	8-1.25mm x 35mm Hex Bolts
1	Passenger/right side Rear Mounting Bracket	4	8mm x 28mm x 3mm Flat Washers
1	Driver/left side Front Support Bracket	4	8mm Lock Washers
1	Passenger/right side Front Support Bracket	8	6-1.0mm x 25mm Hex Bolts
1	Driver/left side Rear Support Bracket	16	6mm x 22mm x 2mm Flat Washers
1	Passenger/right side Rear Support Bracket	8	6-1.0mm Nylon Lock Nuts

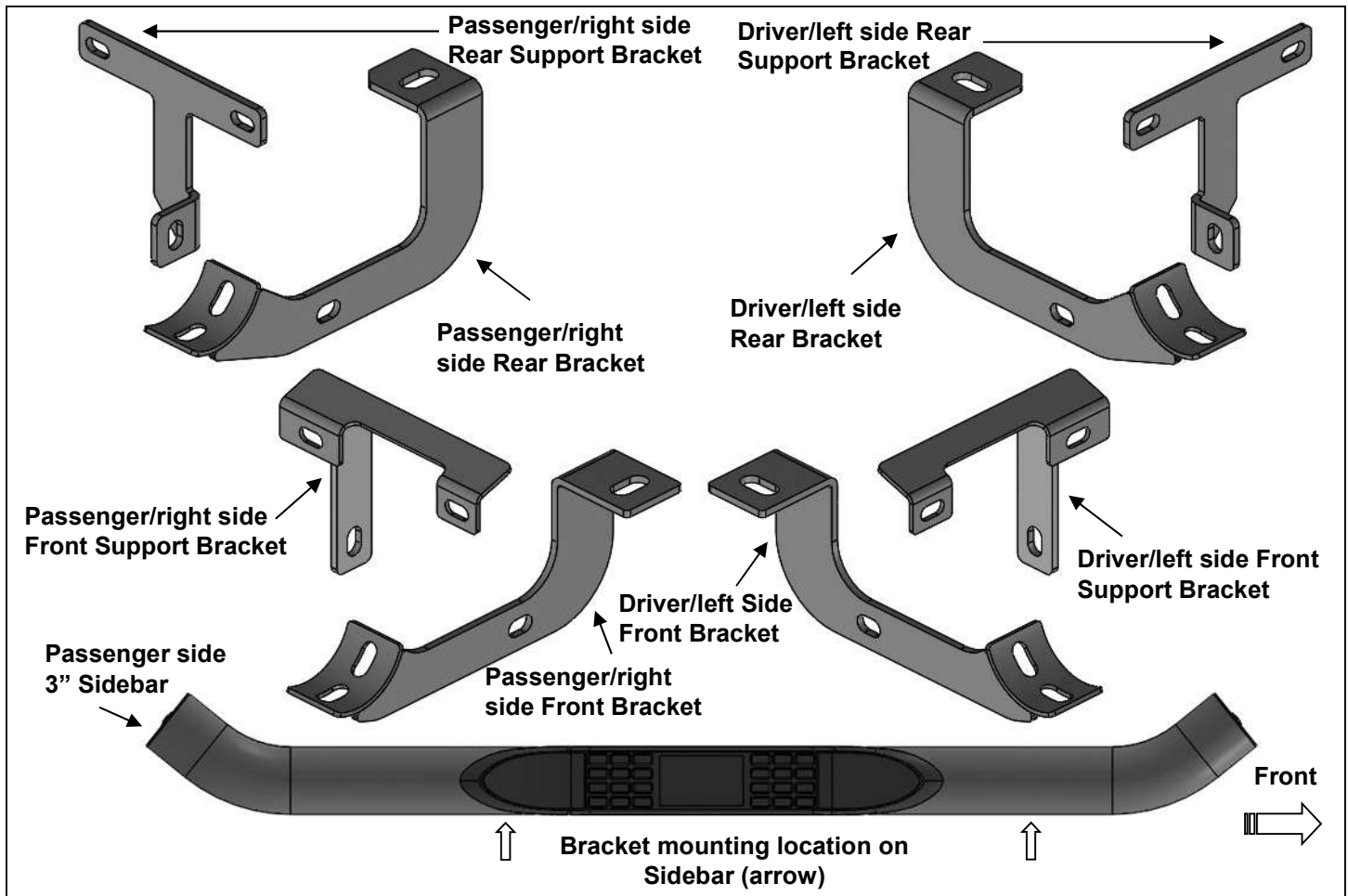

**PROCEDURE:**

**REMOVE CONTENTS FROM BOX. VERIFY ALL PARTS ARE PRESENT. READ INSTRUCTIONS CAREFULLY BEFORE STARTING INSTALLATION. FACTORY INSTALLED OR AFTERMARKET "ROCK RAILS," SIDE STEPS OR RUNNING BOARDS MUST BE REMOVED.**

1. Start installation toward the front of the passenger side of the vehicle and find the front threaded insert located in between the first pair of holes along the pinch weld, **(Figure 1)**.
2. Select the Passenger side Front Mounting Bracket, **(Figure 2)**. **IMPORTANT:** Use the illustration above to properly identify the Mounting Bracket. Attach the Bracket to the threaded insert using (1) 8mm Hex Bolt, (1) 8mm Lock Washer and (1) 8mm Flat Washer, **(Figure 2)**. Do not tighten hardware at this time.
3. Next, select the Passenger side Front Support Bracket, **(Figure 3)**. **IMPORTANT:** Use the illustration above to help identify the correct Support Bracket. Use (1) 10mm Hex Bolt, (2) 10mm Flat Washers and (1) 10mm Nylon Lock Nut to attach the Support Bracket to the rear side of the Front Mounting Bracket, **(Figure 3)**. Attach the Support Bracket to the back of the pinch weld using (2) 6mm Hex Bolts, (4) 6 mm Flat Washers and (2) 6mm Nylon Lock Nuts, **(Figures 4 & 5)**. **NOTE:** Insert bolts from the outside of the pinch weld and through the Bracket. Do not tighten hardware at this time.
4. Move to the rear mounting location and locate the threaded insert and pair of holes on the pinch weld, **(Figure 6)**. Repeat **Steps 3 & 4** to install the Rear Brackets, **(Figure 7)**.
5. Select the Passenger/right Sidebar. Use the illustration above to select the correct Sidebar. Carefully position the Sidebar onto the (2) Mounting Brackets. **IMPORTANT:** Do not slide, (front to back or rotate), the Sidebar on the Brackets or damage to the finish on the Sidebar

may result. Attach the Sidebar to the Mounting Brackets with (4) 8mm x 25mm Combination Hex Bolts, (**Figures 8—10**). Do not tighten hardware.

6. Level and adjust the Sidebar and tighten all hardware.
7. Repeat **Steps 1—7** for Driver/left Sidebar installation.
8. Do periodic inspections to the installation to make sure that all hardware is secure and tight.

### Passenger/right Side Installation Pictured

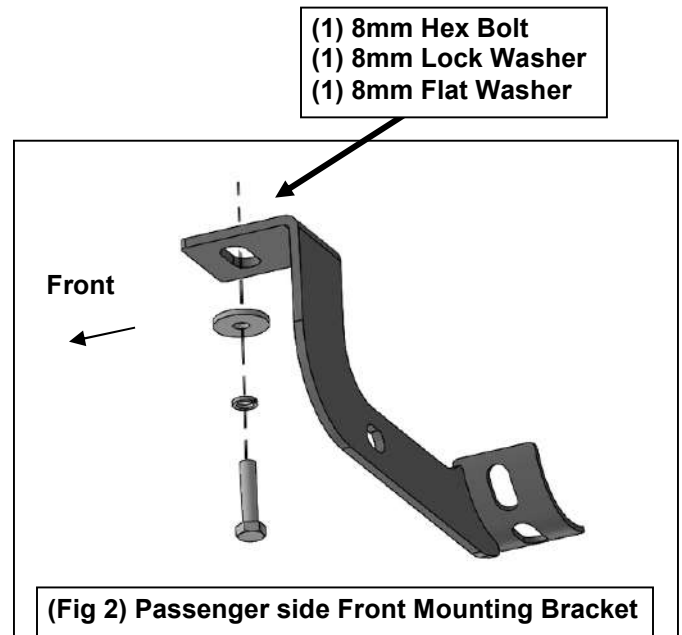
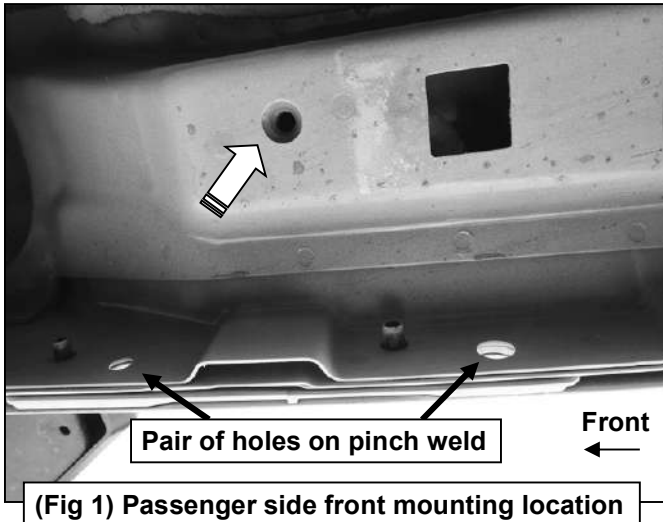

## Passenger/right Side Installation Pictured

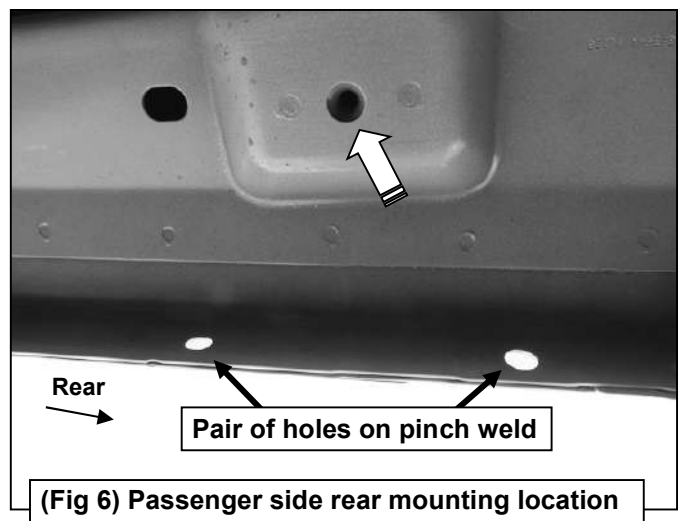
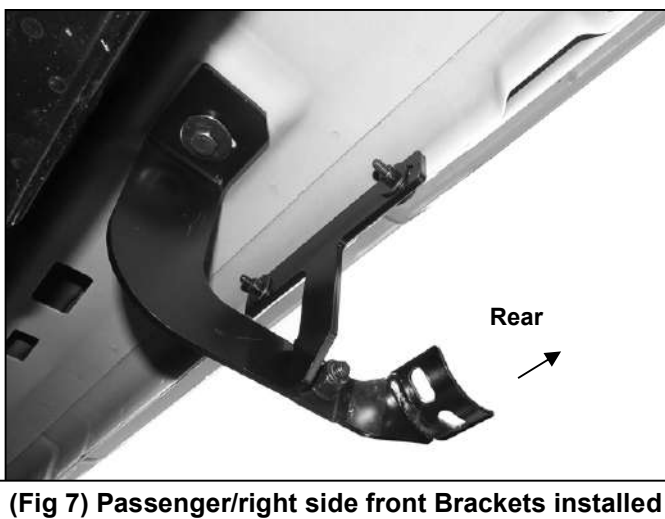
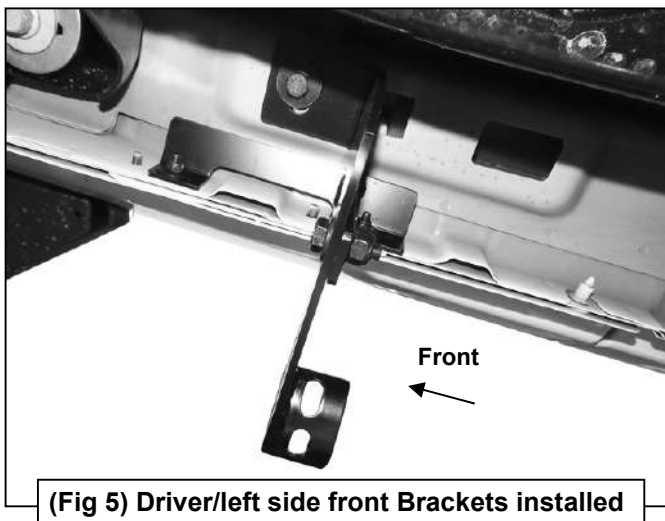
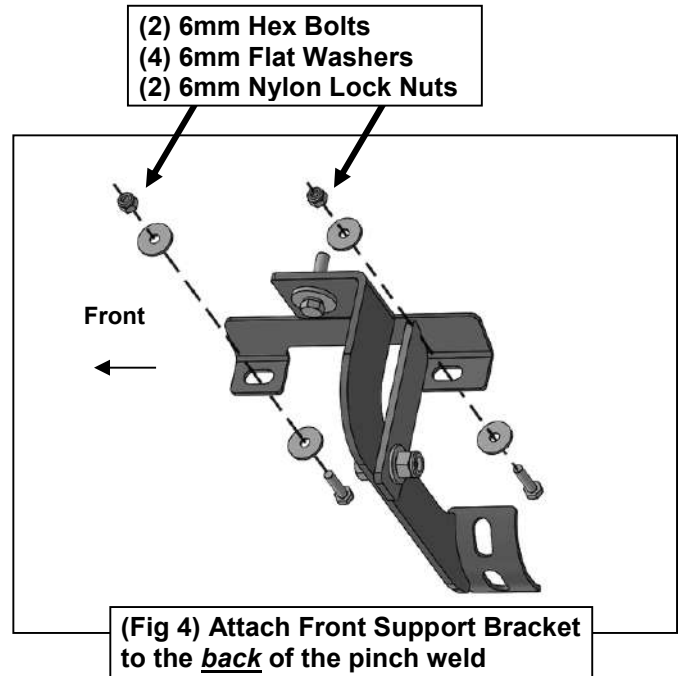
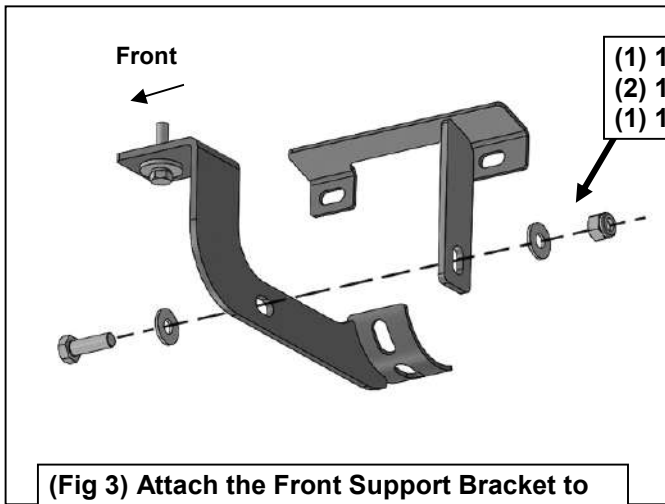

## Passenger/right side Installation Pictured

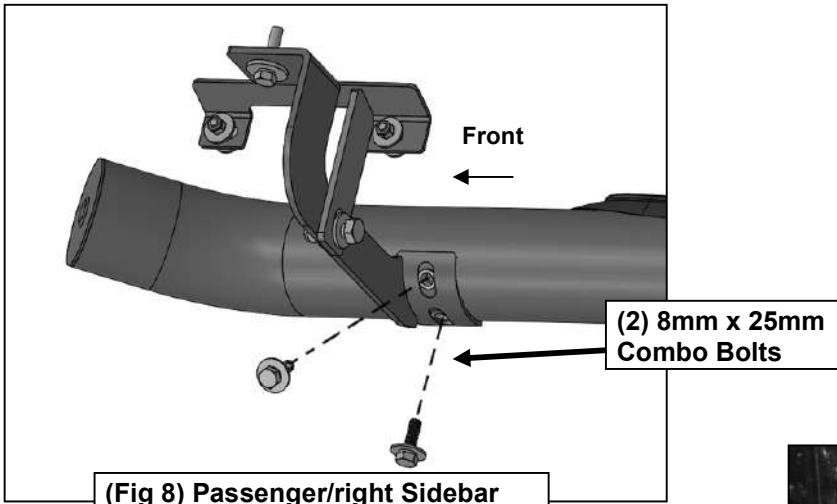

(Fig 8) Passenger/right Sidebar attached to front Brackets

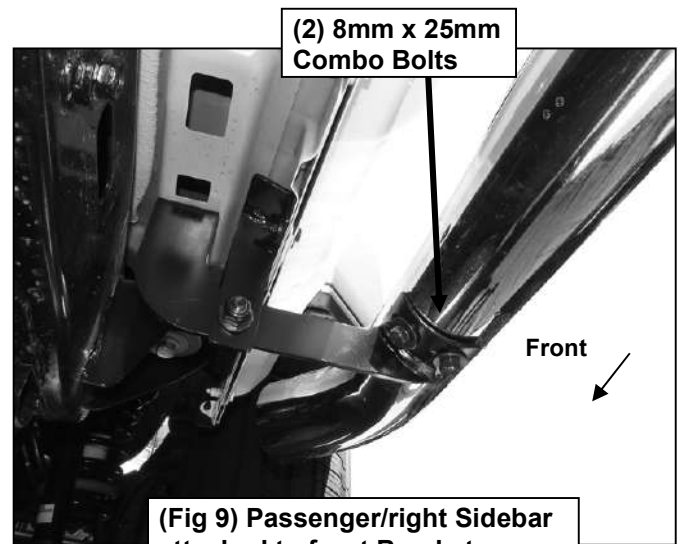

(Fig 9) Passenger/right Sidebar attached to front Brackets

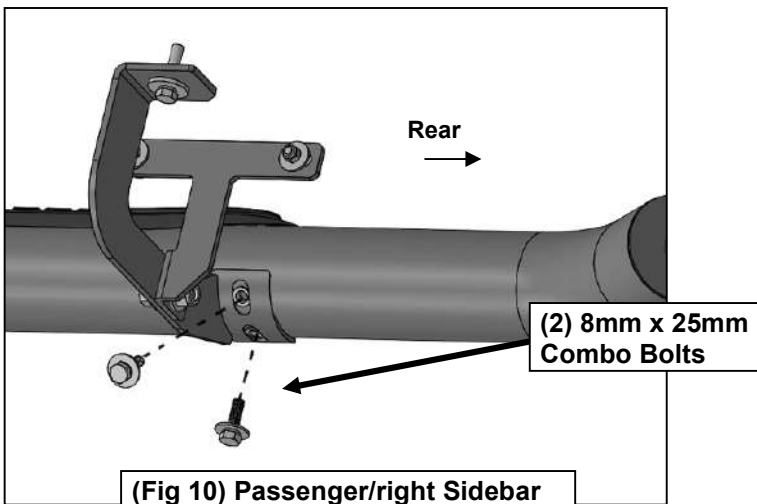

(Fig 10) Passenger/right Sidebar attached to rear Brackets

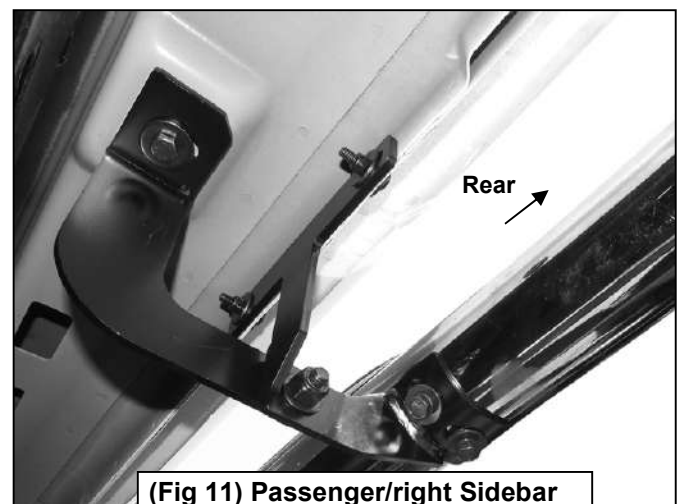

(Fig 11) Passenger/right Sidebar attached to rear Brackets

No.	Parts Identification
1	Passenger / Right 'Rear' Bracket marked "PR"
2	Driver / Left 'Rear' Bracket marked "DR"
3	Passenger / Right 'Center' Bracket marked "PC"
4	Driver / Left 'Center' Bracket marked "DC"
5	Passenger / Right 'Front' Bracket marked "PF"
6	Driver / Left 'Front' Bracket marked "DF"

**Note:**

- > This guide is to identify the parts and not a reference for part count.
- > For part count, refer Parts List.
- > Product / Bracket image is representative and actual design may vary.

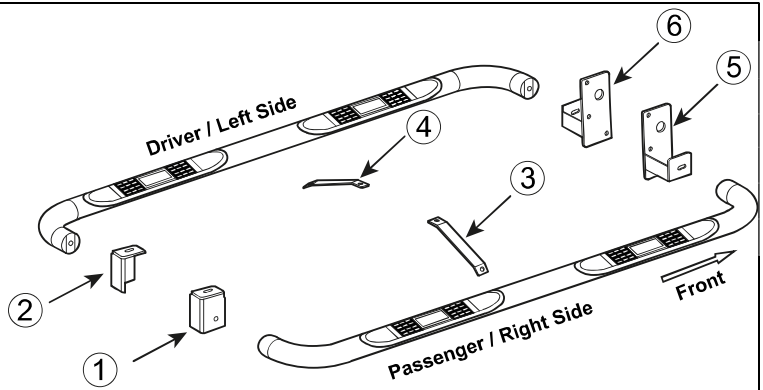

**PRODUCT CARE**

- Periodically check the product to ensure all fasteners are tight and components are intact.
- Regular waxing is recommended to protect the finish of the product.
- **Use ONLY Non-Abrasive automotive wax.** Use of any soap, polish or wax that contains an abrasive is detrimental and can scratch the finish leading to corrosion.
- Aluminum polish may be used to polish small scratches and scuffs for **Stainless Steel finish.**
- Mild soap may be used to clean the product for both **Stainless Steel and Black finish.**

**FAQ's**

**1. Hardware's are not of correct size.**

*In GMC / Chevrolet truck model 2006 & up, customer needs to reuse the factory body bolts to install the bracket. If your vehicle is not GMC / Chevrolet 2006 & up, ensure that holes are not partially covered with any plastic grommet or rust? If it is, remove the plastic grommet & rust from the thread holes & re-try the installation.*

**2. Mounting Bracket are not getting Installed properly.**

*In some cases Illustration images shown in Installation manual may not be the exactly same as per actual vehicle images ,also if Driver / Passenger side mounting brackets are very identical in the design, suggest referring Parts Identification guide to avoid fitment issue.*

**3. Products are thumping / rattling after installation.**

*Ensure that all required mounting brackets / hardware's are installed & tighten correctly. Suggest using white lithium / regular grease between the metal to metal contact surfaces.*

**4. Side Bar is not aligning with vehicle / Step Pads are not aligning with vehicle doors.**

*Side bar may be interchanged or mounting brackets are not installed at the correct position in the vehicle. Refer Parts identification guide.*

**5. Missing / Excess Hardware.**

*Recheck hardware count as per the part list.*

**6. Product not installing properly.**

*Ensure make model year, cab length and bed size of your vehicle is listed in the application. All installation steps are followed correctly.*

**Check out these other TrailFX Products!!**



Keystone Automotive Operations Inc. (KAO) warrants this product to be free of defects in material and workmanship at the time of purchase by the original retail consumer. KAO disclaims any other warranties, express or implied, including the warranty of fitness for a particular purpose or an intended use. If the product is found to be defective, KAO may replace or repair the product at our option, when the product is returned prepaid, with proof of purchase. Alteration to, improper installation, or misuse of this product voids the warranty. KAO's liability is limited to repair or replacement of products found to be defective, and specifically excludes liability for any incidental or consequential loss or damage.