



3" Side Bar

Part No. A0053S /B



Dodge Ram 1500 Crew Cab

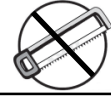

60-180 min

Cutting Not Required

Drilling Not Required



REMOVE CONTENTS FROM BOX. VERIFY ALL PARTS ARE PRESENT.



READ INSTRUCTIONS CAREFULLY BEFORE STARTING INSTALLATION.

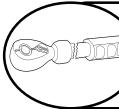

DO NOT OVER TORQUE. STANDARD OPERATING LOAD FOR TIGHTEN BODY MOUNT NUTS & BOLTS VARIES FROM 45 TO 65 FOOT POUND.

PARTS LIST:

Qty	Part Description	Qty	Part Description
1	Driver/left side 3" 90 deg. Bent End Sidebar	1	Passenger/right side Rear Support Bracket
1	Passenger/right side 3" 90 deg. Bent End Sidebar	4	1/2" x 2" Hex Bolts
2	Driver Front/ Passenger Rear Mounting Brackets	4	1/2" x 1-1/2" x 1/8" Flat Washers
2	Passenger Front/Driver Rear Mounting Brackets	4	1/2" Lock Washers
1	Driver/left side Front Support Bracket	12	8-1.25mm Nylon Lock Nuts
1	Passenger/right side Front Support Bracket	12	8mm x 24mm x 2mm Flat Washers
1	Driver/left side Rear Support Bracket		

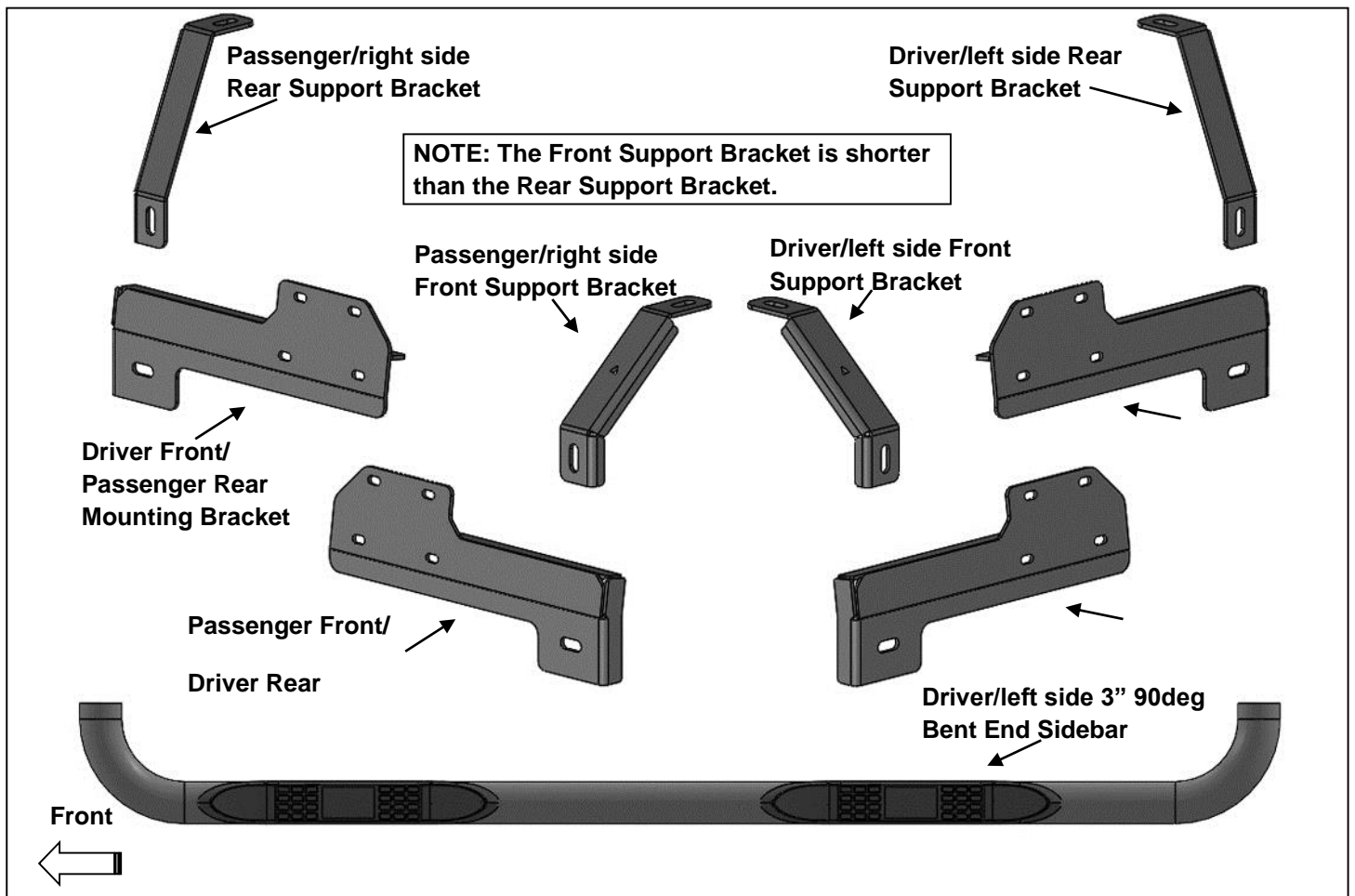

INSTALLATION PROCEDURE:

1. Start the installation under the driver/left side of the vehicle. Locate the front (3) factory studs along the inner side of the body panel, **(Figure 1)**. **NOTE:** Chase threads on the studs first before installing Brackets to remove paint buildup.
2. Select (1) Driver/left side Front Mounting Bracket. Attach the Mounting Bracket to the (3) factory studs with (3) 8mm Flat Washers and (3) 8mm Nylon Lock Nuts, **(Figures 2 & 3)**. Leave Bracket loose at this time.
3. Locate the front body mount, **(Figure 4)**. Remove the factory body bolt and factory washer, **(Figure 5)**. **NOTE:** Chase thread on body bolt to remove paint buildup before reinstalling. Select the Driver/left side Front Support Bracket, **(Figure 6)**. Line up the upper slot on the Bracket with the body bolt hole. Reuse the factory body bolt and washer to attach the Bracket to the top of the body mount, **(Figure 7)**.
4. Move to the rear mounting location, **(Figure 8)**. Repeat **Steps 2 & 3** for Driver/left Rear Mounting Bracket and Driver/left Rear Support Bracket installation, **(Figures 9 & 10)**.
5. Carefully unwrap and select the Driver/left 3" Sidebar. Use the illustration above to help identify the correct Sidebar. With assistance, line up the front end of the tube with the front Bracket slots, **(Figure 11)**. Use (2) 1/2" Hex Bolts, (2) 1/2" Lock Washer and (2) 1/2" Flat Washers to attach the front end of the Sidebar tube to the Front Brackets, **(Figures 11 & 12)**. Snug but do not tighten hardware at this time.
6. Move to the rear end of the Sidebar tube and repeat **Step 5** to attach the Sidebar to the rear Brackets, **(Figure 13)**.
7. Level and adjust the Sidebar as necessary and fully tighten all hardware.
8. Repeat **Steps 1—7** for Passenger/right 3" Sidebar installation.
9. Do periodic inspections to the installation to make sure that all hardware is secure and tight.

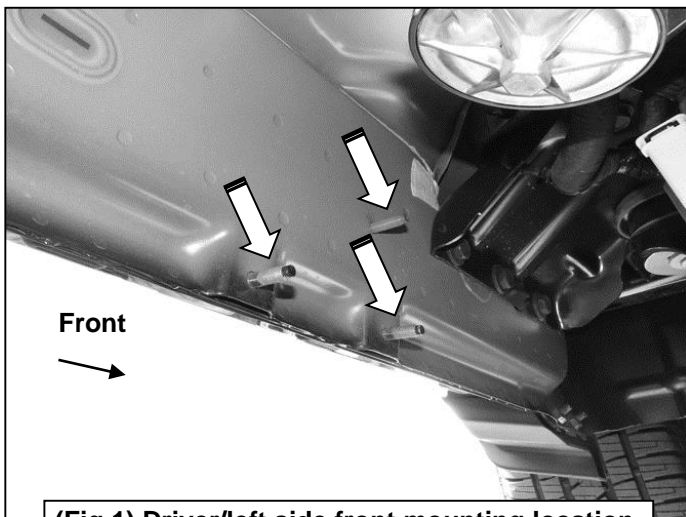

(Fig 1) Driver/left side front mounting location

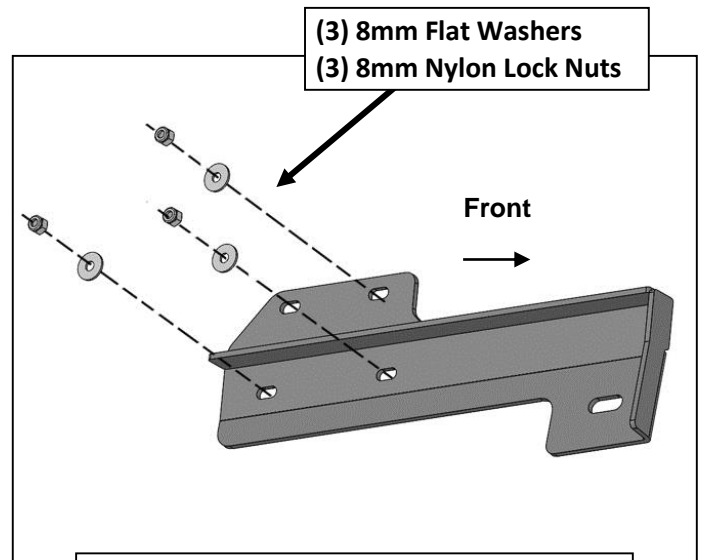

(Fig 2) Driver/left side Front Mounting Bracket attached to Side Panel illustrated

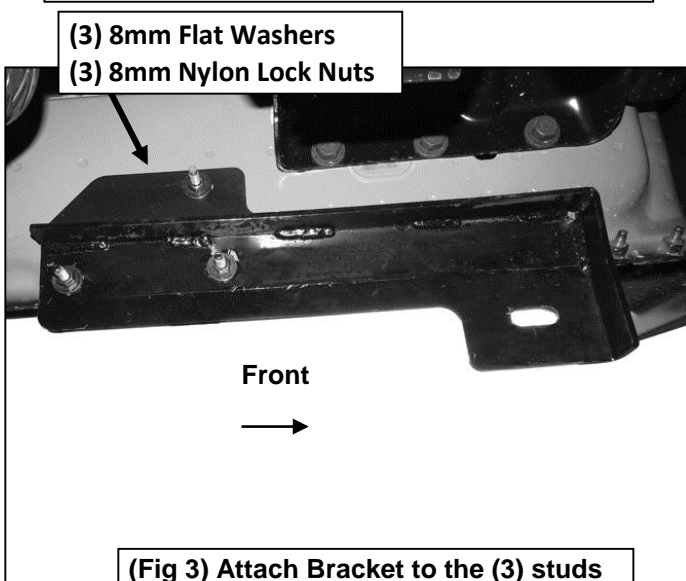

(Fig 3) Attach Bracket to the (3) studs

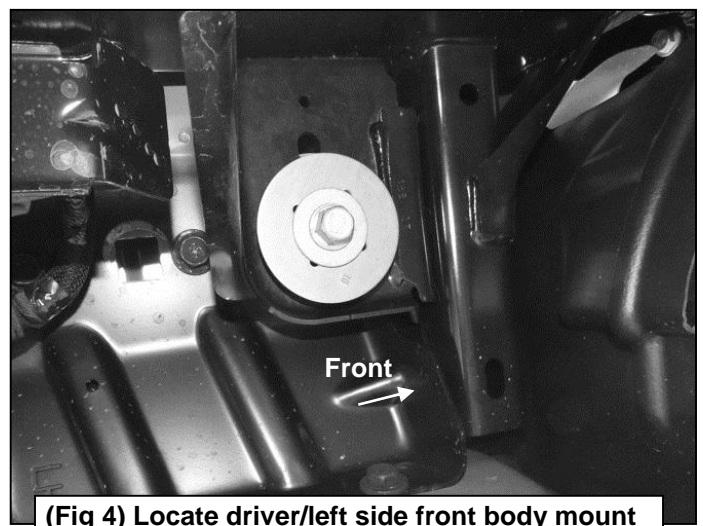

(Fig 4) Locate driver/left side front body mount

Driver/left Side Installation Pictured

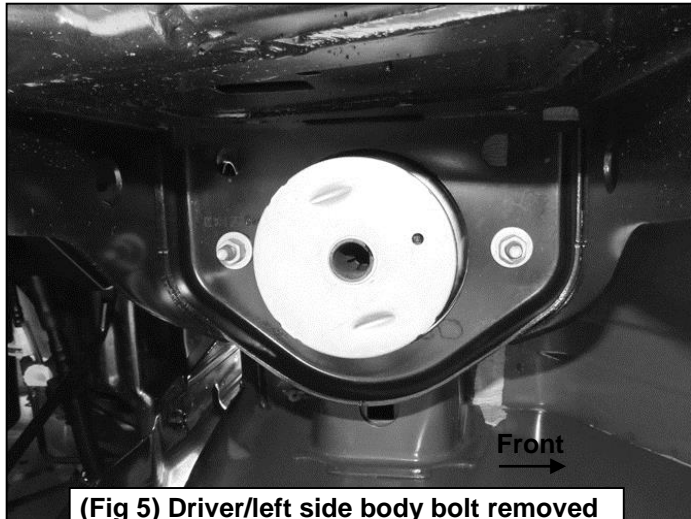

(Fig 5) Driver/left side body bolt removed

NOTE: The Front Support Bracket is shorter than the Rear Support Bracket.

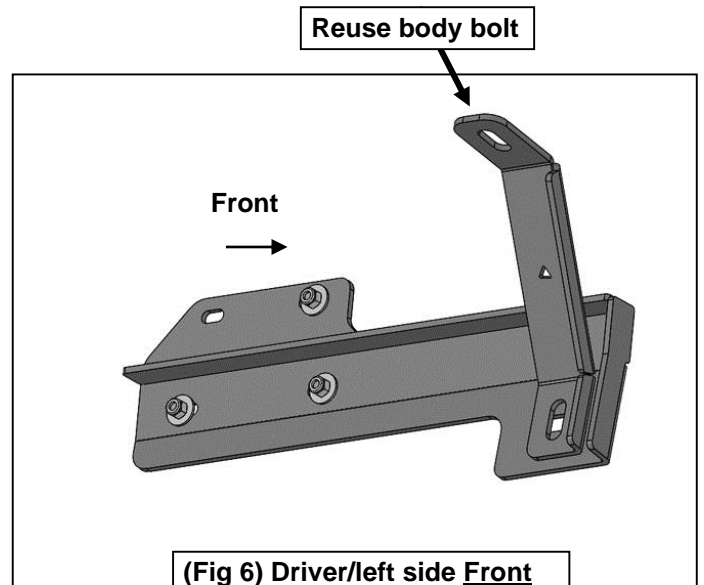

(Fig 6) Driver/left side Front Support Bracket illustrated

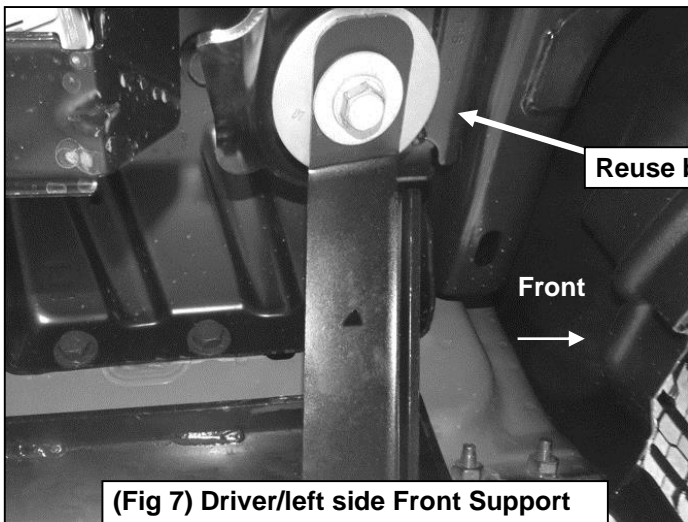

(Fig 7) Driver/left side Front Support Bracket attached to body mount

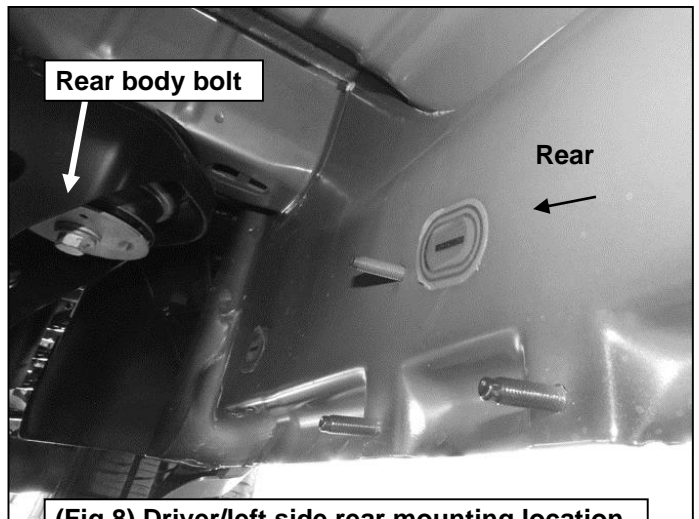

(Fig 8) Driver/left side rear mounting location

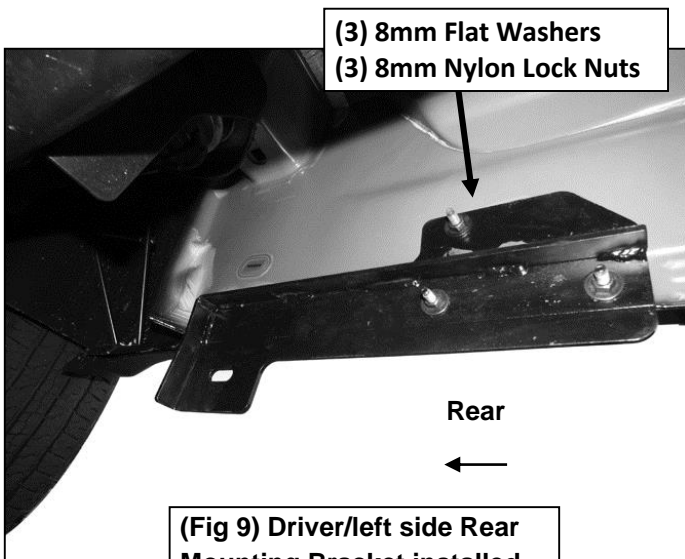

(Fig 9) Driver/left side Rear Mounting Bracket installed

Driver/left Side Installation Pictured

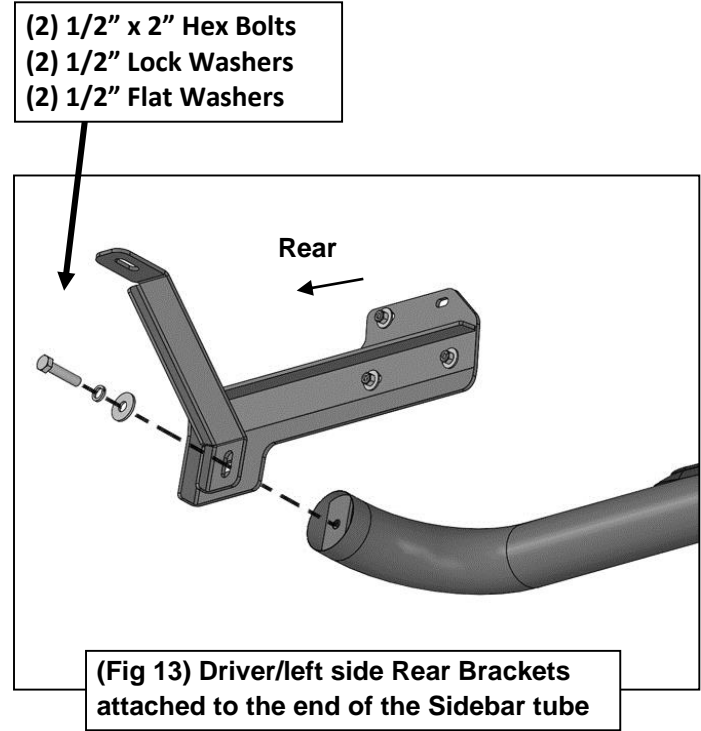
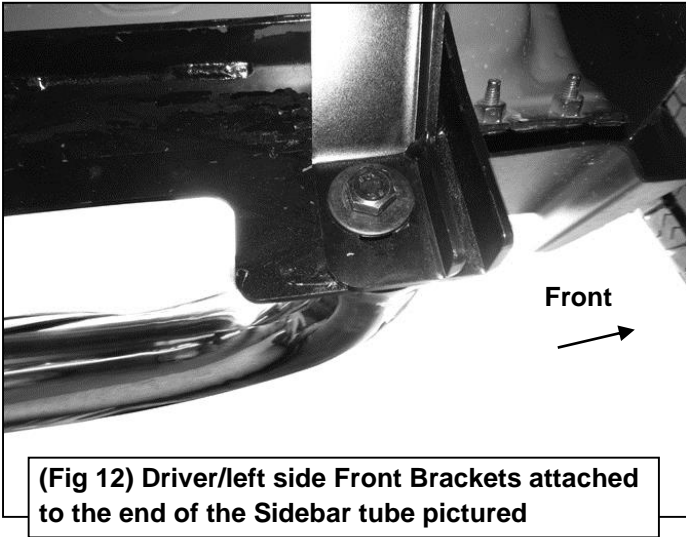
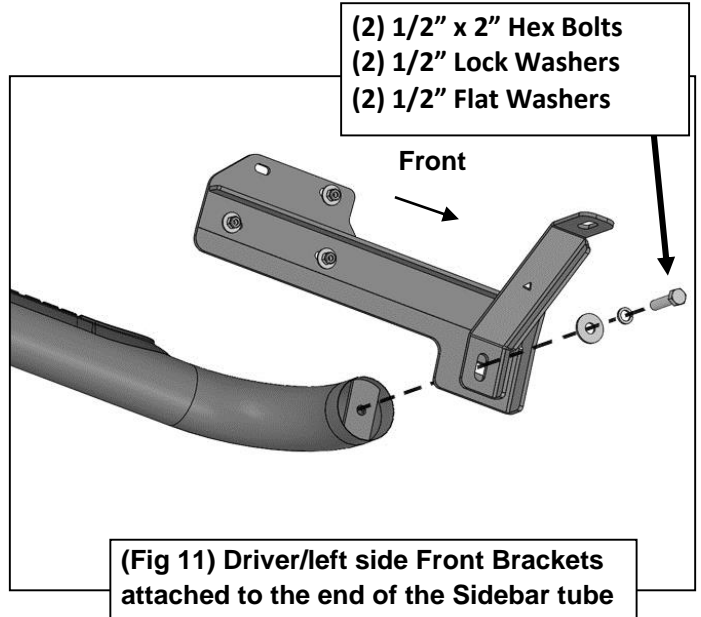
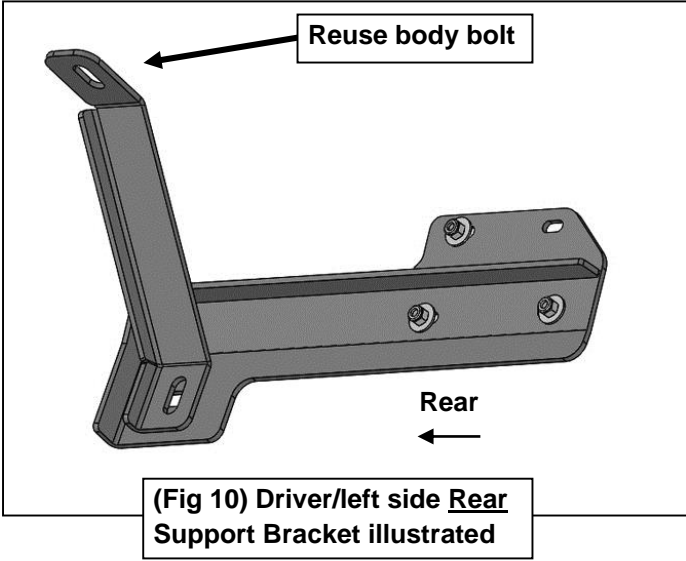

No.	Parts Identification
1	Passenger / Right 'Rear' Bracket marked "PR"
2	Driver / Left 'Rear' Bracket marked "DR"
3	Passenger / Right 'Center' Bracket marked "PC"
4	Driver / Left 'Center' Bracket marked "DC"
5	Passenger / Right 'Front' Bracket marked "PF"
6	Driver / Left 'Front' Bracket marked "DF"

Note:

- This guide is to identify the parts and not a reference for part count.
- For part count, refer Parts List.
- Product / Bracket image is representative and actual design may vary.

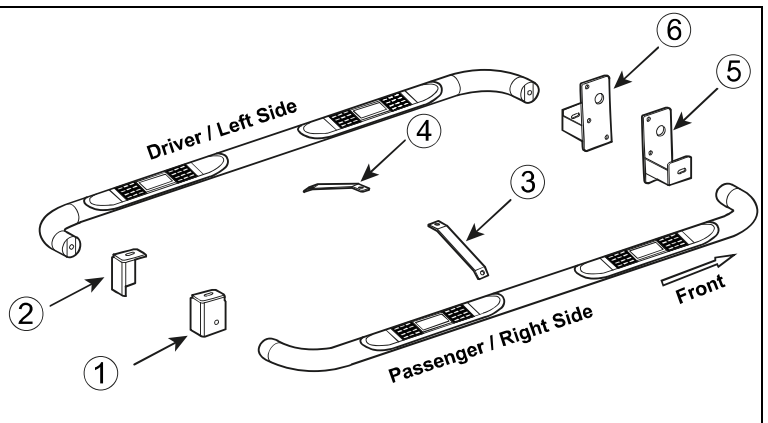

PRODUCT CARE

- Periodically check the product to ensure all fasteners are tight and components are intact.
- Regular waxing is recommended to protect the finish of the product.
- **Use ONLY Non-Abrasive automotive wax.** Use of any soap, polish or wax that contains an abrasive is detrimental and can scratch the finish leading to corrosion.
- Aluminum polish may be used to polish small scratches and scuffs for **Stainless Steel finish.**
- Mild soap may be used to clean the product for both **Stainless Steel and Black finish.**

FAQ's

1. Hardware's are not of correct size.

In GMC / Chevrolet truck model 2006 & up, customer needs to reuse the factory body bolts to install the bracket. If your vehicle is not GMC / Chevrolet 2006 & up, ensure that holes are not partially covered with any plastic grommet or rust? If it is, remove the plastic grommet & rust from the thread holes & re-try the installation.

2. Mounting Bracket are not getting Installed properly.

In some cases Illustration images shown in Installation manual may not be the exactly same as per actual vehicle images ,also if Driver / Passenger side mounting brackets are very identical in the design, suggest referring Parts Identification guide to avoid fitment issue.

3. Products are thumping / rattling after installation.

Ensure that all required mounting brackets / hardware's are installed & tighten correctly. Suggest using white lithium / regular grease between the metal to metal contact surfaces.

4. Side Bar is not aligning with vehicle / Step Pads are not aligning with vehicle doors.

Side bar may be interchanged or mounting brackets are not installed at the correct position in the vehicle. Refer Parts identification guide.

5. Missing / Excess Hardware.

Recheck hardware count as per the part list.

6. Product not installing properly.

Ensure make model year, cab length and bed size of your vehicle is listed in the application. All installation steps are followed correctly.

Check out these other TrailFX Products!!



Keystone Automotive Operations Inc. (KAO) warrants this product to be free of defects in material and workmanship at the time of purchase by the original retail consumer. KAO disclaims any other warranties, express or implied, including the warranty of fitness for a particular purpose or an intended use. If the product is found to be defective, KAO may replace or repair the product at our option, when the product is returned prepaid, with proof of purchase. Alteration to, improper installation, or misuse of this product voids the warranty. KAO's liability is limited to repair or replacement of products found to be defective, and specifically excludes liability for any incidental or consequential loss or damage.