

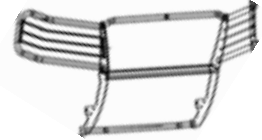

# Grille Guard

Part No. 81050/1



Fits: **2003 - 2007 Chevrolet Avalanche 1500 (Without Body Cladding)**  
**2003 - 2006 Chevrolet Silverado**  
**2003 - 2007 Chevrolet "Classic" 1500LD & Z71**



On models without tow hooks, some modification of lower bumper fascia is necessary. Access to the tow hooks is limited after installation.



60-180 min



Cutting Required



Drilling Not Required



REMOVE CONTENTS FROM BOX. VERIFY ALL PARTS ARE PRESENT.



READ INSTRUCTIONS CAREFULLY BEFORE STARTING INSTALLATION.

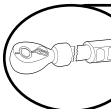

DO NOT OVER TORQUE. STANDARD OPERATING LOAD FOR TIGHTEN BODY MOUNT NUTS & BOLTS VARIES FROM **45 TO 65 FOOT POUND.**

### PARTS LIST:

Qty	Part Description	Qty	Part Description
1	Driver/Left Frame Mounting Bracket	20	12mm x 32mm OD x 3mm Flat Washers
1	Passenger/Right Frame Mounting Bracket	10	12mm Nylon Lock Nuts
1	Driver/Left Top Bracket	2	10-1.50mm x 25mm Button Head Allen Bolts
1	Passenger/Right Top Bracket	4	10mm x 20mm OD x 2mm Flat Washers
10	12-1.75mm x 30mm Hex Bolts	2	10mm Nylon Lock Nuts

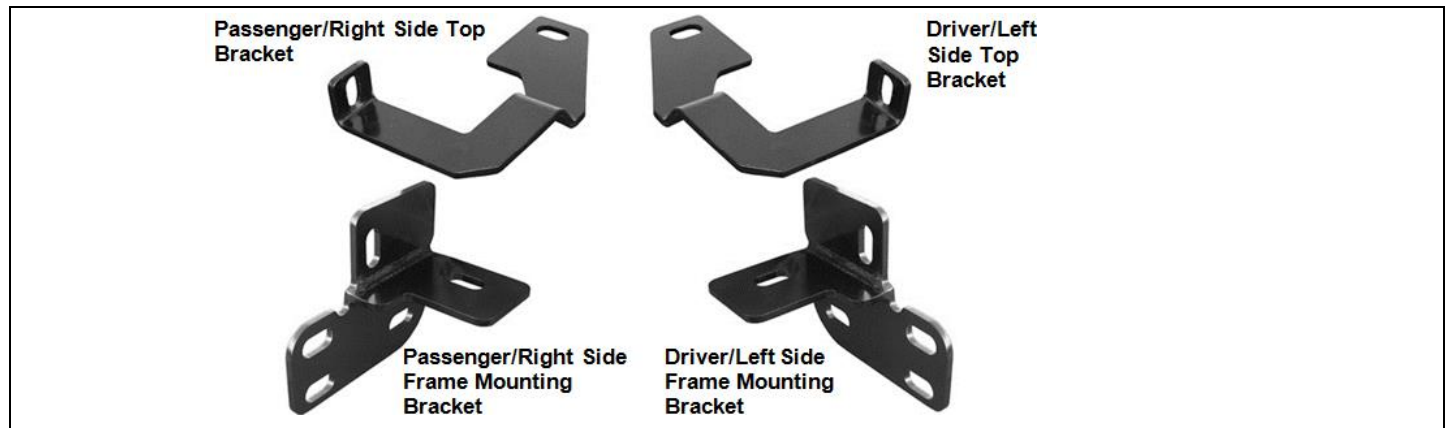

**Install Note:** Cutting may be required. On models without tow hooks, some modification of lower bumper fascia is necessary. Access to the tow hooks is limited after installation.

**NOTE:** On some model years, the tow hooks may be reinstalled but must be switched, driver side to passenger side to clear the Frame Mounting Bracket. Depending on model year, the plastic bumper cover may not clear the tow hook when switched side to side as pictured on Page 3 & 4. If the tow hook will fit properly, re-use the factory tow hook hardware to bolt the Frame Mounting Brackets to the vehicle. Otherwise, do not reinstall the tow hooks. It is up to the installer to determine if the tow hooks can be properly reinstalled and some trimming of the back of the plastic bumper cover may be required.

### INSTALLATION PROCEDURE

- Starting on the driver side-front of the vehicle, locate the opening in the lower bumper cover at the front end of the frame. Select the driver side Frame Mounting Bracket. Remove the tow hook if equipped. **NOTE:** This Grille Guard may not be compatible with the factory tow hooks and they may not be reinstalled. See note below.
- Insert (1) 12mm x 30mm Hex Bolt with (1) 12mm Flat Washer through the opening in the front of the frame and out through the hole in the bottom of the frame. Line up the driver side Frame Mounting Bracket with the 12mm Hex Bolt. Secure with (1) 12mm Flat Washer and (1) 12mm Nylon Lock Nut. Repeat this step for the 2nd mounting location on the outer side of the frame. Do not tighten hardware at this time. **IMPORTANT:** On some vehicles, it may be necessary to remove the lower

plastic portion of the bumper to gain access to the ends of the frame rails. The indented pockets in the bumper also may need to be cut out to allow the Mounting Brackets to pass through.

3. Repeat Step 2 for the passenger side Frame Mounting Bracket installation. Snug but do not tighten the hardware at this time.
4. Next, open the hood on the vehicle and locate the cross member behind the bumper cover and grille. Locate and remove the factory hex bolt on the top of the cross member. Insert the driver side Top Bracket through the opening in the bumper and bolt it to the crossmember with the factory hardware. Leave loose at this time.
5. Repeat Step 4 for passenger side Top Bracket installation.
6. With assistance, place the Grille Guard up to the inside of the Frame Mounting Brackets. Secure the Grille Guard to the Brackets with (6) 12mm x 30mm Hex Bolts, (12) 12mm Flat Washers and (6) 12mm Nylon Lock Nuts. Do not tighten hardware at this time.
7. Next, move to the driver side Top Bracket installed in Step 4. Line up the Top Bracket with the hole in the Grille Guard upright. Insert (1) 10mm Button Head Bolt with (1) 10mm Flat Washer through the upright and Top Bracket. Secure with (1) 10mm Flat Washer and (1) 10mm Nylon Lock Nut. Repeat this step on the passenger side Top Bracket. Do not tighten at this time.
8. With the hood open, align, center and adjust the Grille Guard properly and tighten all Mounting Bracket and Support Bracket hardware. Carefully close the hood and check for clearance. Adjust the Brackets for fit as necessary.
9. Do periodic inspections to the installation to make sure that all hardware is secure and tight.

### ***Driver Side Installation Pictured***

**Remove tow hooks if equipped**

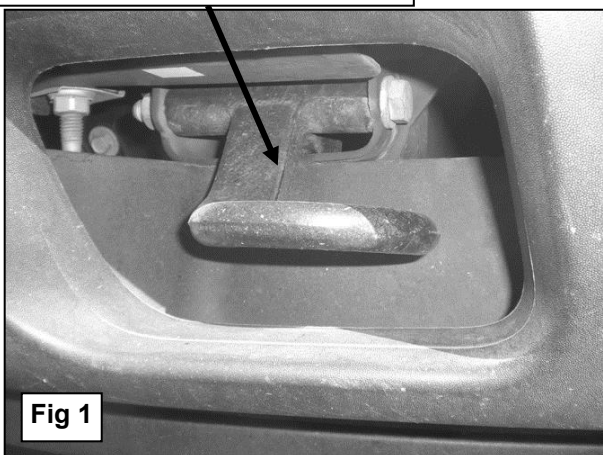

**Fig 1**

**NOTE: On vehicles without tow hooks, the area above may be covered by an indented plastic panel. Cut or remove the fill panel as required to gain access to the front of the frame rail to allow bottom brackets to pass through.**

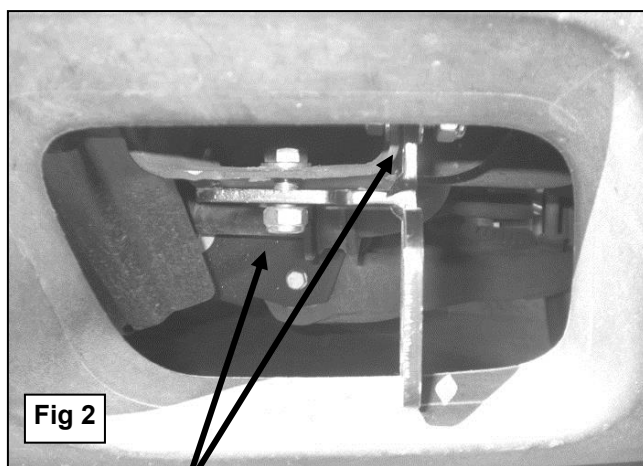

**Fig 2**

**(2) 12mm x 30mm Hex Bolts  
(4) 12mm Flat Washers  
(2) 12mm Nylon Lock Nuts**

**Driver Side Installation Pictured**

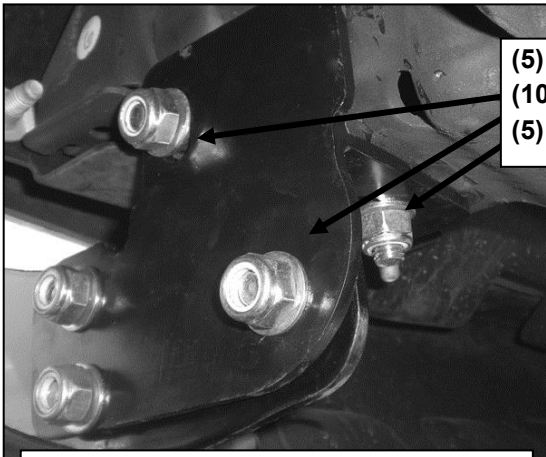

(5) 12mm x 30mm Hex Bolts  
(10) 12mm Flat Washers  
(5) 12mm Nylon Lock Nuts

(Fig 3) Pictured from behind bumper

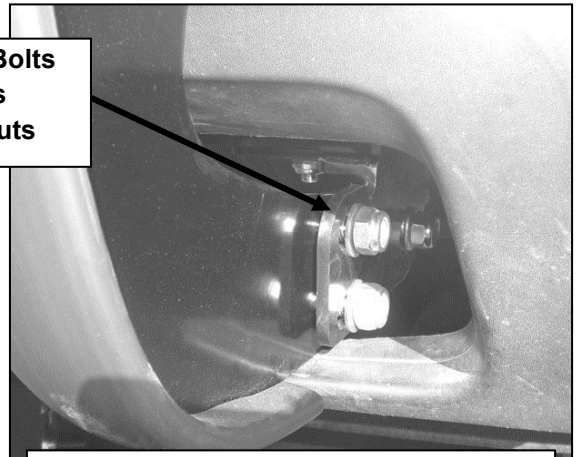

(Fig 4) Pictured from in front of bumper

**Passenger Side Installation Pictured**

Factory bolt, passenger side bumper opening pictured

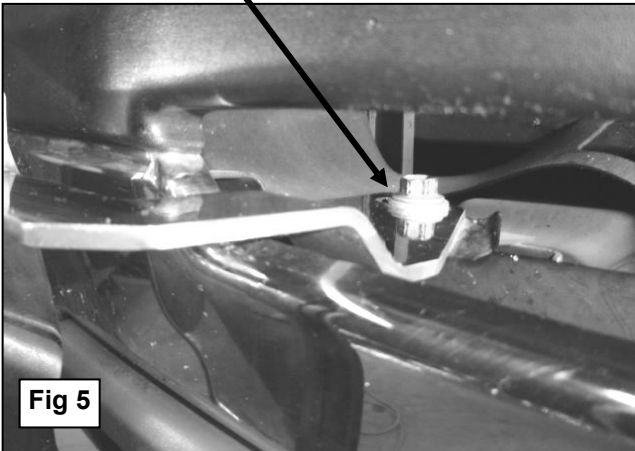
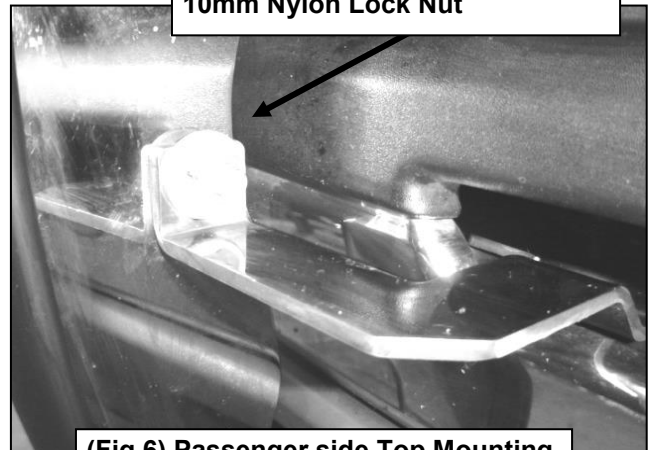
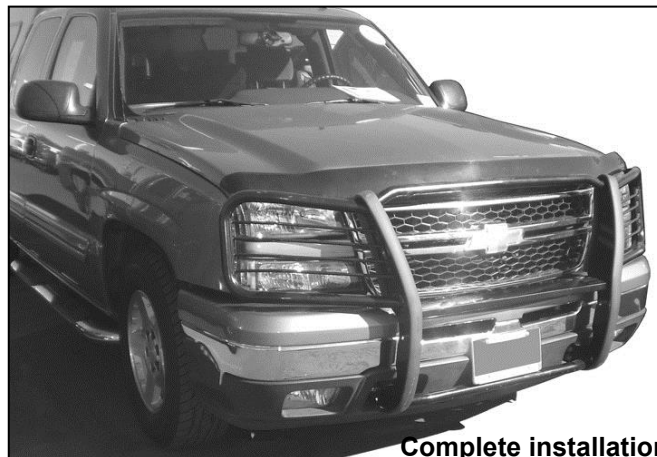

Fig 5

10mm x 25mm Button Head Bolt  
(2) 10mm Flat Washers  
10mm Nylon Lock Nut



(Fig 6) Passenger side Top Mounting Bracket installation pictured



Complete installation

## PRODUCT CARE

- Periodically check the product to ensure all fasteners are tight and components are intact.
- Regular waxing is recommended to protect the finish of the product.
- **Use ONLY Non-Abrasive automotive wax.** Use of any soap, polish or wax that contains an abrasive is detrimental and can scratch the finish leading to corrosion.
- Aluminum polish may be used to polish small scratches and scuffs for **Stainless Steel finish.**
- Mild soap may be used to clean the product for both **Stainless Steel and Black finish.**

## FAQ's

**1. Hardware's are not of correct size.**

*In GMC / Chevrolet truck model 2006 & up, customer needs to reuse the factory body bolts to install the bracket. If your vehicle is not GMC / Chevrolet 2006 & up, ensure that holes are not partially covered with any plastic grommet or rust? If it is, remove the plastic grommet & rust from the thread holes & re-try the installation.*

**2. Mounting Bracket are not getting Installed properly.**

*In some cases Illustration images shown in Installation manual may not be the exactly same as per actual vehicle images ,also if Driver / Passenger side mounting brackets are very identical in the design, suggest referring Parts Identification guide to avoid fitment issue.*

**3. Products are thumping / rattling after installation.**

*Ensure that all required mounting brackets / hardware's are installed & tighten correctly. Suggest using white lithium / regular grease between the metal to metal contact surfaces.*

**4. Side Bar is not aligning with vehicle / Step Pads are not aligning with vehicle doors.**

*Side bar may be interchanged or mounting brackets are not installed at the correct position in the vehicle. Refer Parts identification guide.*

**5. Missing / Excess Hardware.**

*Recheck hardware count as per the part list.*

**6. Product not installing properly.**

*Ensure make model year, cab length and bed size of your vehicle is listed in the application. All installation steps are followed correctly.*