

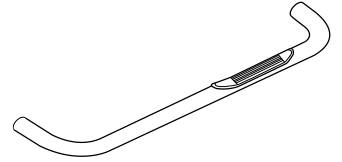

3" Side Bar

Part No. 1130301971/3



Fits: 1997-2003
1997-2004

Ford F150 Standard Cab
Ford F250 LD Standard Cab



30-60 min

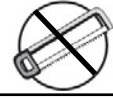

Cutting Not Required



Drilling Not Required



REMOVE CONTENTS FROM BOX. VERIFY ALL PARTS ARE PRESENT.



READ INSTRUCTIONS CAREFULLY BEFORE STARTING INSTALLATION.

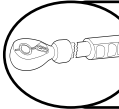

DO NOT OVER TORQUE. STANDARD OPERATING LOAD FOR TIGHTEN BODY MOUNT NUTS & BOLTS VARIES FROM 45 TO 65 FOOT POUND.

PARTS LIST:

Qty	Part Description	Qty	Part Description
1 Set	Side Bar	4	1/2" Lock Washer
1 Set	Front Bracket	4	3/8"-16 x 1 1/2" Large Bolt Plate
1 Set	Rear Bracket	8	3/8" Flat Washer
4	1/2"-13 x 2" Hex Head Bolt	8	3/8" Lock Washer
4	1/2" Flat Washer	8	3/8" -16 Hex Nut

DRIVER (LEFT) FRONT	DRIVER (LEFT) REAR	PASSENGER (RIGHT) REAR	PASSENGER (RIGHT) FRONT

INSTALLATION PROCEDURE

⚠ IMPORTANT: A magnetic pick up tool is recommended to assist with the installation.

1. Remove the end caps on the side bars before beginning installation.
2. Remove the rubber plugs from the two holes on each inside face of the sheet metal rocker panel. (Figure 1).
3. Install the front mounting bracket by placing bolt plate through hole in body as shown in figure 1. Position front bracket with downward sloping end towards front of vehicle. Assemble with 3/8" flat washers, 3/8" lock washers and 3/8" hex nuts. (See Figure 1)
4. Install rear mounting bracket same as front only with the downward sloping end towards the rear of the vehicle.
5. Install the side bar using the 1/2" x 2 1/2" hex head bolts, 1/2" flat washers, and 1/2" lock washers.
6. After all mounting points are in place and Side Bars are aligned, tighten all bolts accordingly. Recheck bolts periodically.

**FIGURE 1
PASSENGER SIDE**

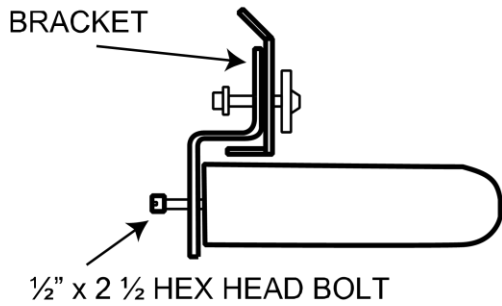
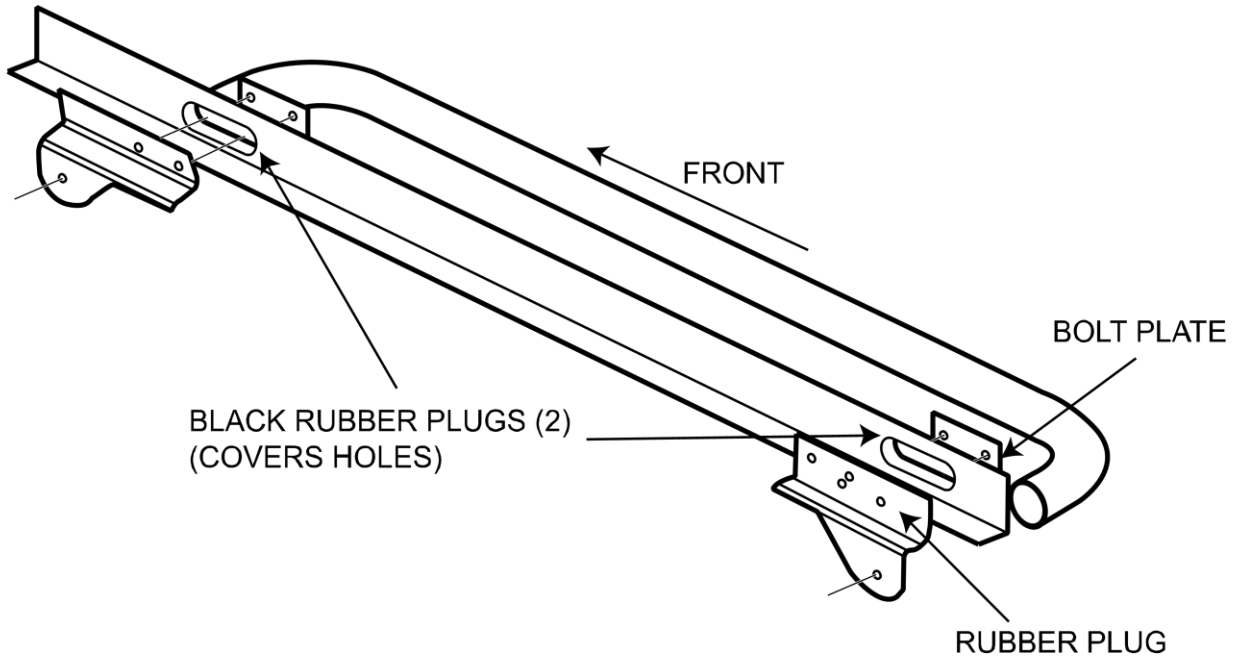

**FIGURE 3
REAR BRACKET**

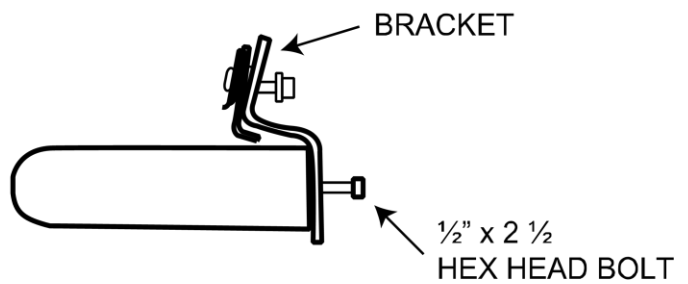
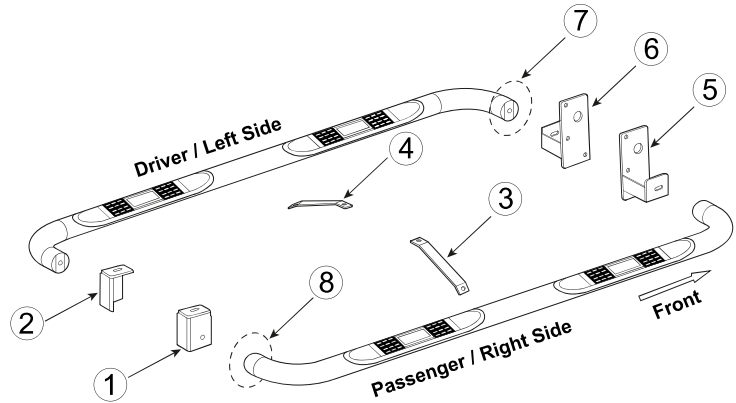

**FIGURE 2
FRONT BRACKET**

PARTS IDENTIFICATION GUIDE

Driver Side tube taped in "Red" Color. Passenger Side tube taped in "Blue" Color.

No.	Parts Identification
1	Passenger / Right 'Rear' Bracket marked "RR"
2	Driver / Left 'Rear' Bracket marked "RL"
3	Passenger / Right 'Center' Bracket marked "CR"
4	Driver / Left 'Center' Bracket marked "CL"
5	Passenger / Right 'Front' Bracket marked "FR"
6	Driver / Left 'Front' Bracket marked "FL"
7	'Left' marked "L"
8	'Right' marked "R"



Note:

- This guide is to identify the parts and not a reference for part count.
- Product / Bracket image is for representative purpose only.
- Actual design may vary based on application.
- Refer Parts List for Hardware.

PRODUCT CARE

- Periodically check the product to ensure all fasteners are tight and components are intact.
- Regular waxing is recommended to protect the finish of the product.
- **Use ONLY Non-Abrasive automotive wax.** Use of any soap, polish or wax that contains an abrasive is detrimental and can scratch the finish leading to corrosion.
- Aluminum polish may be used to polish small scratches and scuffs for **Stainless Steel finish.**
- Mild soap may be used to clean the product for both **Stainless Steel and Black finish.**

FAQ's

1. Hardware's are not of correct size.

In GMC / Chevrolet truck model 2006 & up, customer needs to reuse the factory body bolts to install the bracket. If your vehicle is not GMC / Chevrolet 2006 & up, ensure that holes are not partially covered with any plastic grommet or rust? If it is, remove the plastic grommet & rust from the thread holes & re-try the installation.

2. Mounting Bracket are not getting Installed properly.

In some cases Illustration images shown in Installation manual may not be the exactly same as per actual vehicle images ,also if Driver / Passenger side mounting brackets are very identical in the design, suggest referring Parts Identification guide to avoid fitment issue.

3. Products are thumping / rattling after installation.

Ensure that all required mounting brackets / hardware's are installed & tighten correctly. Suggest using white lithium / regular grease between the metal to metal contact surfaces.

4. Side Bar is not aligning with vehicle / Step Pads are not aligning with vehicle doors.

Side bar may be interchanged or mounting brackets are not installed at the correct position in the vehicle. Refer Parts identification guide.

5. Missing / Excess Hardware.

Recheck hardware count as per the part list.

6. Product not installing properly.

Ensure make model year, cab length and bed size of your vehicle is listed in the application. All installation steps are followed correctly.