

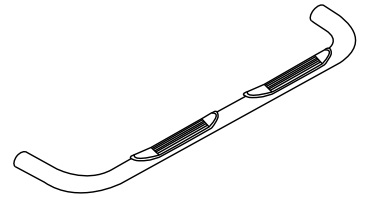

3" Side Bar

Part No. 1120223941/3



- Fits:** 1998 - 2001 Dodge Ram 1500 Quad Cab
 1998 - 2002 Dodge Ram 2500/3500 Quad Cab
 1995 - 2001 Dodge Ram 1500 Club Cab
 1995 - 1999 Dodge Ram 2500 Club Cab
 1995 - 1997 Dodge Ram 3500 Club Cab



RECOMMENDED FOR QUAD CAB. CAN BE USED FOR CLUB CAB, BUT ADDITIONAL STEP PAD ON THE REAR MAY NOT BE FOR USE.



30-60 min



Cutting Not Required



Drilling Not Required



REMOVE CONTENTS FROM BOX. VERIFY ALL PARTS ARE PRESENT.



READ INSTRUCTIONS CAREFULLY BEFORE STARTING INSTALLATION.

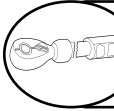

DO NOT OVER TORQUE. STANDARD OPERATING LOAD FOR TIGHTEN BODY MOUNT NUTS & BOLTS VARIES FROM 45 TO 65 FOOT POUND.

PARTS LIST:

Qty	Part Description	Qty	Part Description
1 Set	Side Bar	12	3/8"-16 Hex Nut
1 Set	Front Bracket	12	3/8" External Tooth Lock Washer
1 Set	Rear Bracket	2	3/8"-16 x 7" Tee Bolt
4	M12-1.75 x 120mm Hex Head Bolt	2	3/8"-16 x 8" Tee Bolt
4	1/2"-13 x 1 1/2" Hex Head Bolt	2	Rear Angle Clip
8	1/2" Flat Washer	2	Front Angle Clip
8	1/2" Lock Washer	4	3" Aluminum Sleeve

DRIVER (LEFT) FRONT	DRIVER (LEFT) REAR	PASSENGER (RIGHT) REAR	PASSENGER (RIGHT) FRONT

INSTALLATION PROCEDURE

⚠ IMPORTANT: A magnetic pick up tool is recommended to assist with the installation.

1. Remove the end caps on the side bars before beginning installation.
2. Locate the correct Side Bar and set of Brackets referenced to the illustration. (See Illustration 1). Locate the existing bolts on the correct body mounts of the chassis. Remove the four mounting bolts from the vehicle. These are M12-1.75 metric bolts that are not reused in the installation. The body mounting steel washer plate and rubber cushion are reused between the body mount and the side bar mounting bracket.
3. Assemble fasteners on the hanger Tee Bolts as follows: On the front 7.00" long Tee Bolt, assemble the front angle clip and hex nut and tooth washer as shown. (The hex nut within 1 1/2" of the Tee Bolt head). Assemble one hex nut as shown

approximately 4.00" up on the hanger Tee Bolt threads. On the rear 8.00" longer Tee Bolt, assemble the rear angle clip and hex nut as shown. (The hex nut within 1 1/2" of the Tee Bolt head). Assemble on hex nut as shown on the end opposite the Tee Bolt head and approximately 4.00" up on the hanger Tee Bolt threads.

4. Install the head of the front and rear Tee Bolts in the oblong holes in the inclined surface of the body stiffeners so that the head of the Tee Bolt hanger is as shown. Next tighten the upper hex nuts finger tight so that the angle clips are pulled up under the body stiffeners. (Position the clips as shown so that the bottom surface of the clip is horizontal).
5. Position the side bar assembly up under the body mounts. As the assembly is lifted up under the mounts, insert the hanger Tee Bolts through the clearance holes in the side bar. (Make sure you slide on tooth washers on the Tee Bolts before you put the side bar up). Install a hex nut to the bottom of the hanger Tee Bolts. (This will hold the side bar in position for the next step). Pull off one of the hex nuts holding the bar to the Tee bolt. Slide over the Tee Bolt the 3" aluminum sleeve so that it is positioned inside the side bar. Next put on the Hex nut and tooth washer. Repeat this on all four Tee Bolts.
6. Install the M12x1.75x120mm Hex head bolts; 1/2" lock washer and 1/2" flat washer up through the hole in the mounting bracket and the body mounting washer/cushion as shown. Install the 1/2" x 1 1/2" hex bolts through the main front and rear brackets into the side bars.
7. Tighten body mount bolts. Align side bars and tighten all 3/8" nuts on Tee Bolts. Next tighten side bar bolts. Retighten bolts and nuts periodically.

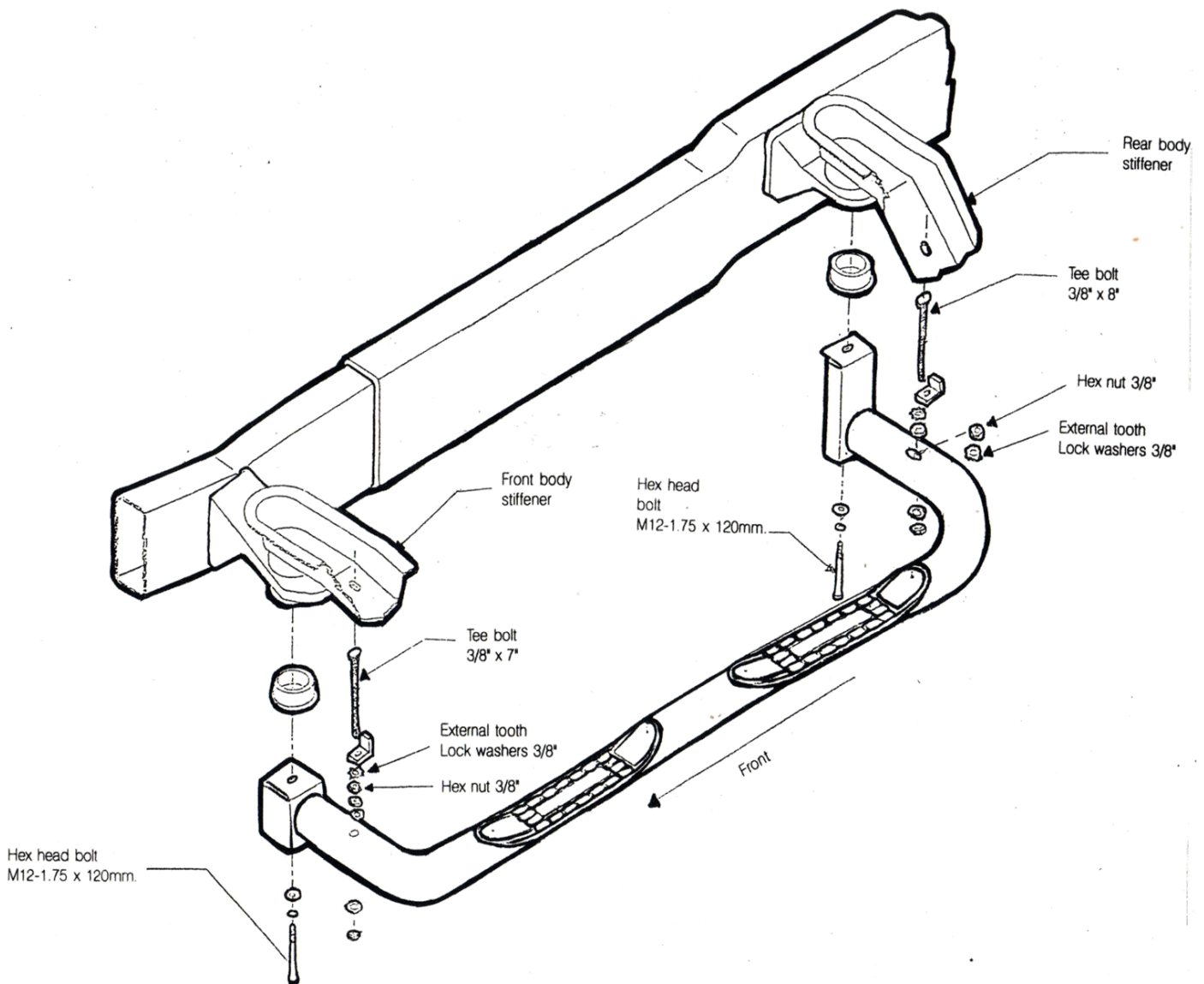

Illustration 1

PARTS IDENTIFICATION GUIDE

Driver Side tube taped in "Red" Color. Passenger Side tube taped in "Blue" Color.

No.	Parts Identification
1	Passenger / Right 'Rear' Bracket marked "RR"
2	Driver / Left 'Rear' Bracket marked "RL"
3	Passenger / Right 'Center' Bracket marked "CR"
4	Driver / Left 'Center' Bracket marked "CL"
5	Passenger / Right 'Front' Bracket marked "FR"
6	Driver / Left 'Front' Bracket marked "FL"
7	'Left' marked "L"
8	'Right' marked "R"

Note:

- This guide is to identify the parts and not a reference for part count.
- Product / Bracket image is for representative purpose only.
- Actual design may vary based on application.
- Refer Parts List for Hardware.

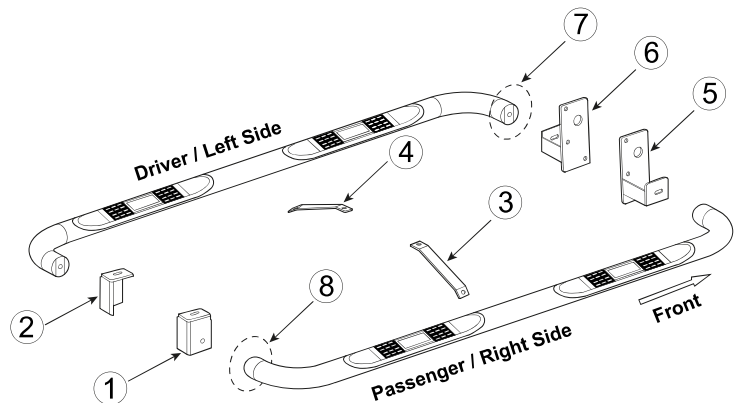

PRODUCT CARE

- Periodically check the product to ensure all fasteners are tight and components are intact.
- Regular waxing is recommended to protect the finish of the product.
- **Use ONLY Non-Abrasive automotive wax.** Use of any soap, polish or wax that contains an abrasive is detrimental and can scratch the finish leading to corrosion.
- Aluminum polish may be used to polish small scratches and scuffs for **Stainless Steel finish.**
- Mild soap may be used to clean the product for both **Stainless Steel and Black finish.**

FAQ's

1. Hardware's are not of correct size.

In GMC / Chevrolet truck model 2006 & up, customer needs to reuse the factory body bolts to install the bracket. If your vehicle is not GMC / Chevrolet 2006 & up, ensure that holes are not partially covered with any plastic grommet or rust? If it is, remove the plastic grommet & rust from the thread holes & re-try the installation.

2. Mounting Bracket are not getting Installed properly.

In some cases Illustration images shown in Installation manual may not be the exactly same as per actual vehicle images ,also if Driver / Passenger side mounting brackets are very identical in the design, suggest referring Parts Identification guide to avoid fitment issue.

3. Products are thumping / rattling after installation.

Ensure that all required mounting brackets / hardware's are installed & tighten correctly. Suggest using white lithium / regular grease between the metal to metal contact surfaces.

4. Side Bar is not aligning with vehicle / Step Pads are not aligning with vehicle doors.

Side bar may be interchanged or mounting brackets are not installed at the correct position in the vehicle. Refer Parts identification guide.

5. Missing / Excess Hardware.

Recheck hardware count as per the part list.

6. Product not installing properly.

Ensure make model year, cab length and bed size of your vehicle is listed in the application. All installation steps are followed correctly.