

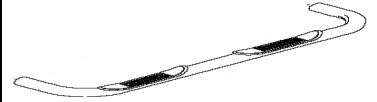

3" Side Bar

Part No. 1110134041/3



Fits: 2004-2012 Chevrolet Colorado / GMC Canyon Crew Cab



60-180 min

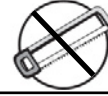

CUTTING NOT
REQUIRED



DRILLING NOT
REQUIRED



REMOVE CONTENTS FROM BOX. VERIFY ALL PARTS ARE PRESENT.



READ INSTRUCTIONS CAREFULLY BEFORE STARTING INSTALLATION.

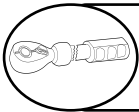

DO NOT OVER TORQUE. STANDARD OPERATING LOAD FOR TIGHTEN BODY MOUNT NUTS & BOLTS VARIES FROM 45 TO 65 FOOT POUND.

PARTS LIST:

Qty	Part Description	Qty	Part Description
1	Driver/Left Sidebar	4	1/2 x 2" Hex Head Bolts
1	Passenger/Right Sidebar	4	1/2 Lock Washers
1	Driver/Left Front Mounting Bracket	4	1/2 x 1-1/2 x 1/8 Flat Washers
1	Passenger/Right Front Mounting Bracket	4	14mm x 50mm OD x 4mm Flat Washers
1	Driver/Left Rear Mounting Bracket	2	12mm Nut Plates
1	Passenger/Right Rear Mounting Bracket	2	12-1.75mm x 120mm Hex Bolts
1	Driver/Left Front Support Bracket	2	12mm x 30mm Hex Head Bolts
1	Passenger/Right Front Support Bracket	6	12mm x 32mm OD x 3mm Flat Washers
1	Driver/Left Rear Support Bracket	4	12mm Lock Washers
1	Passenger/Right Rear Support Bracket	2	12mm Hex Nuts

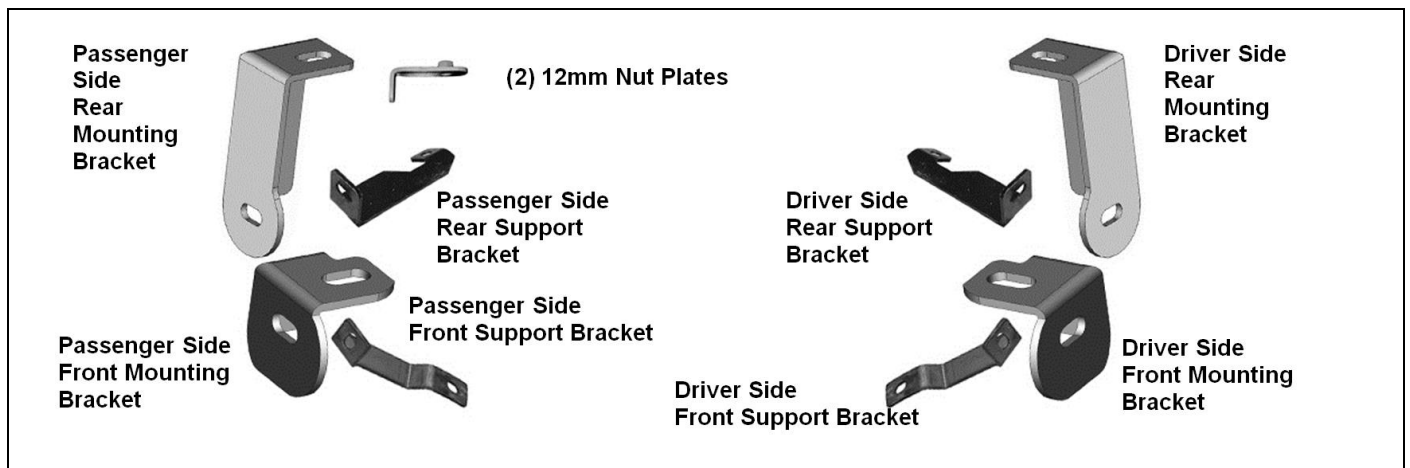

INSTALLATION PROCEDURE

- Starting on the driver side, remove the factory front body mount bolt from the underside of the cab, **(Figure 1)**. **NOTE:** The factory body mount bolts need to be driven out of and back into the steel washer molded into the rubber bushing. Take precautions to avoid damage to the threads on the bolt or the washer and bushing, **(Figure 2)**.

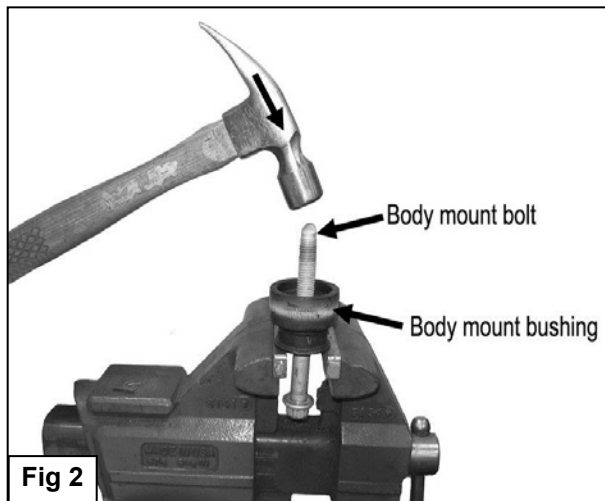
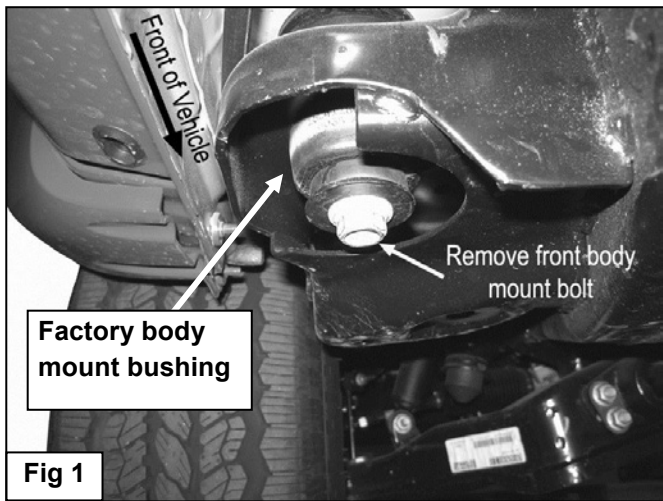

2. Locate the driver side front Mounting Bracket and bolt it to the vehicle using the factory body mount bolt, (Figure 3).
NOTE: Brackets mount over bushings. Do not tighten at this time.

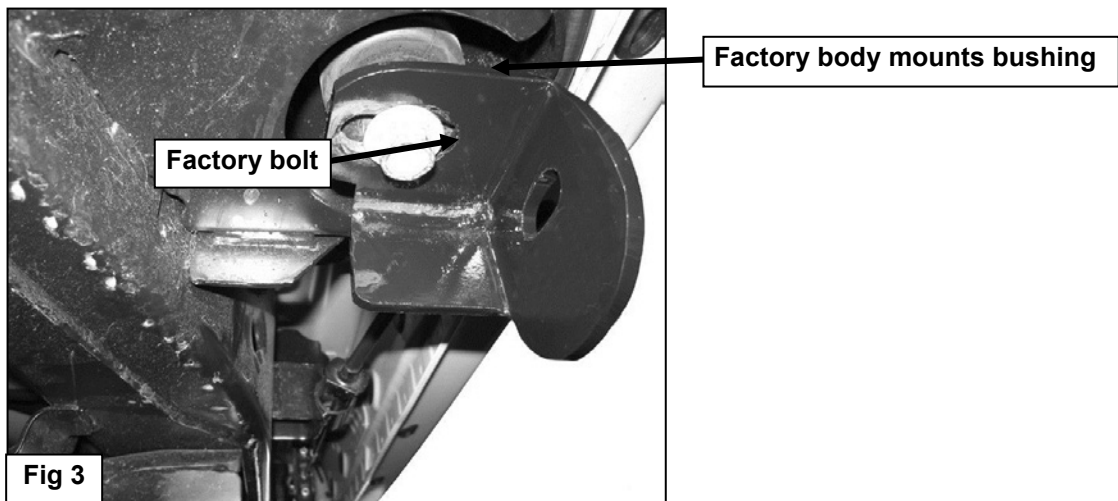

3. Select the driver side Front Support Bracket and insert (1) 12mm x 120mm Hex Bolt with (1) 12mm Flat Washer through the mounting slot. Place (2) 14mm x 50mm OD x 4mm Flat Washers onto the 12mm Hex Bolt between the Support Bracket and the factory body mount, (Figure 4). Insert the 12mm Hex Bolt up through the holes in the factory body mount and secure with (1) 12mm Flat Washer, (1) 12mm Lock Washer and (1) 12mm Hex Nut, (Figure 5A & 5B). Snug but do not tighten hardware at this time.

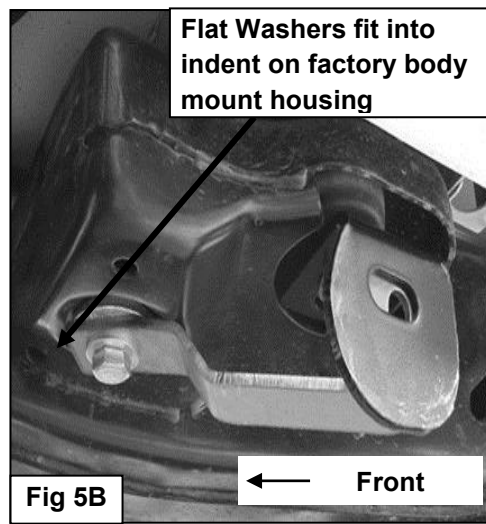
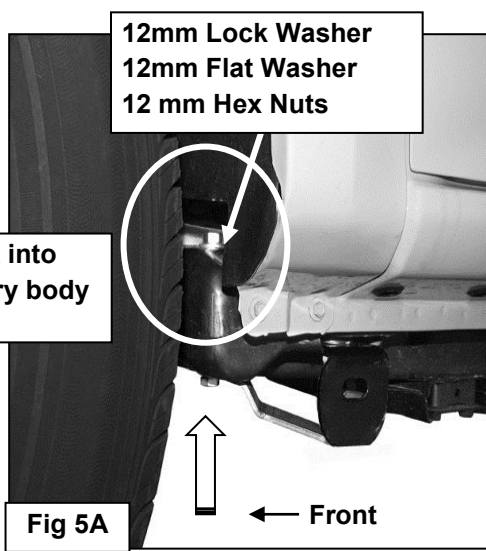
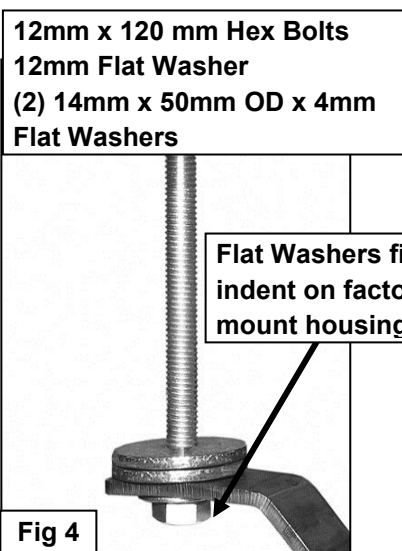

4. Locate the driver side rear Mounting Bracket and bolt it to the vehicle using the factory body mount bolts, (Figure 6A & 6B). **NOTE:** Brackets mount over bushings. Refer to Step 2 for installation instructions. **IMPORTANT:** Position the Mounting Bracket so that there is a minimum 1/4" gap between the rear Mounting Bracket and the inner body panel, (Figure 6B). Do not allow the Mounting Bracket to come in contact with the body panel.

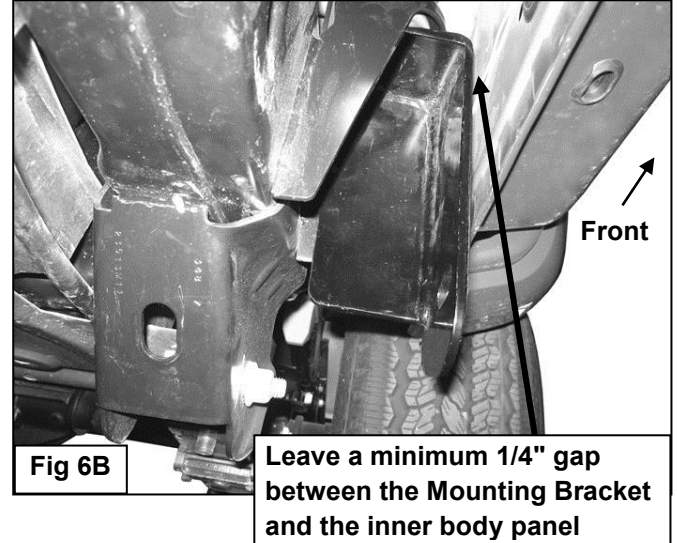
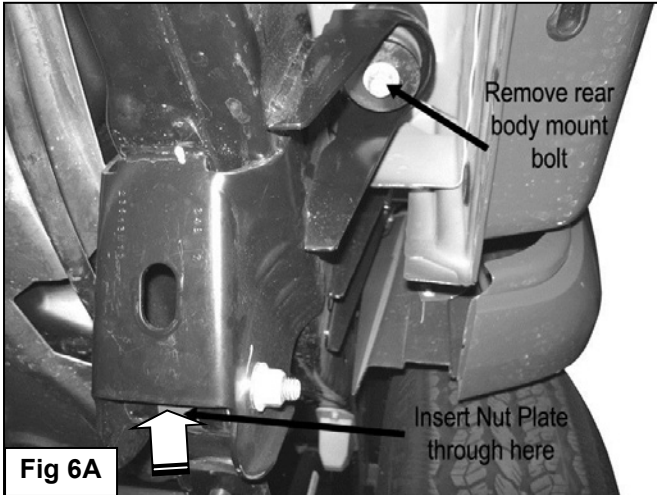

Leave a minimum 1/4" gap between the Mounting Bracket and the inner body panel

5. Insert one of the 12mm Nut Plates through the bottom of the front face of the leaf spring mounting bracket and align it to the factory oval hole, (Figure 6A & 7).

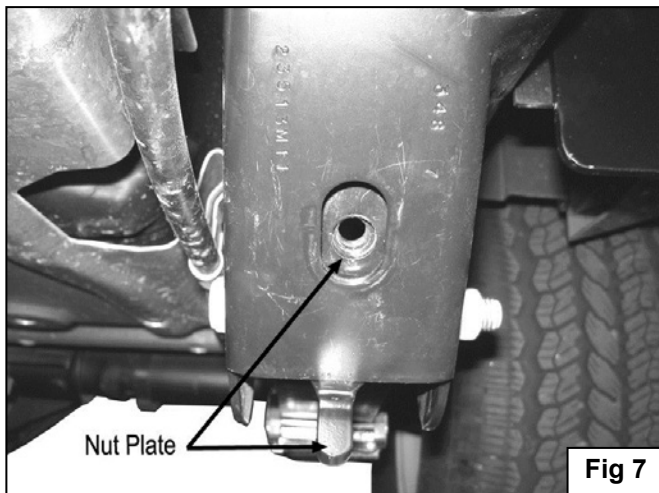

6. With the 90-degree bend towards the side of the vehicle and facing up, partially attach the driver side Support Bracket to the already inserted Nut Plate using the included (1) 12mm x 30mm Hex Head Bolt, (1) 12mm Lock Washer and (1) 12mm Flat Washer, (Figure 8). **NOTE:** When properly installed, the bent end of the Support Bracket should line up with the hole in the Mounting Bracket. Snug but do not tighten hardware at this time.

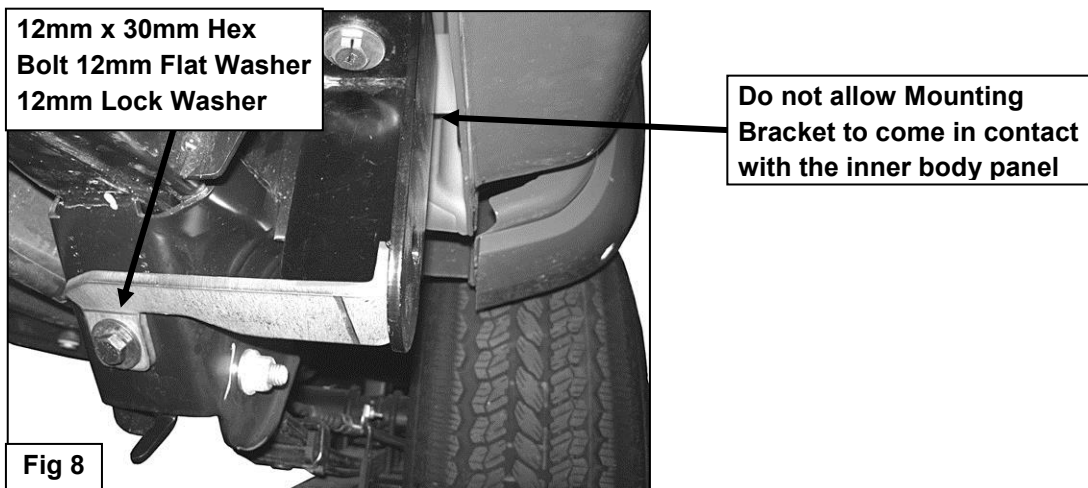

7. Carefully position the driver Sidebar up to the Mounting Brackets. Line up the mounting hole in the Front Support Bracket with the hole in the Front Mounting Bracket, (**Figure 9**). Use the included (2) 1/2" x 2" Hex Head Bolts, (2) 1/2" Lock Washers, and (2) 1/2" Flat Washers to attach the Sidebar to the Mounting Brackets, (**Figure 10 & 11**).

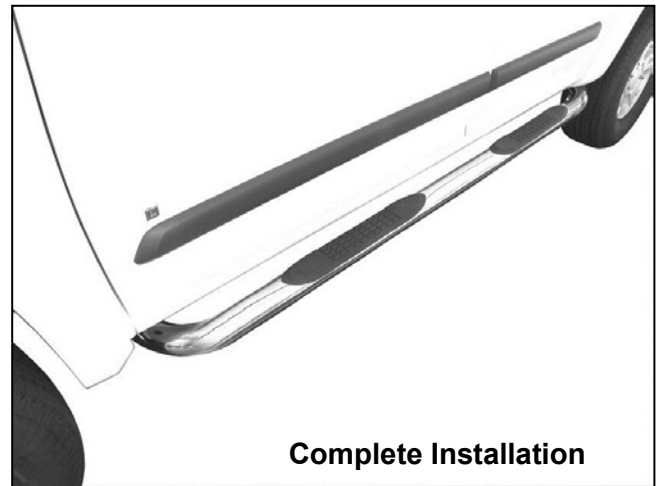
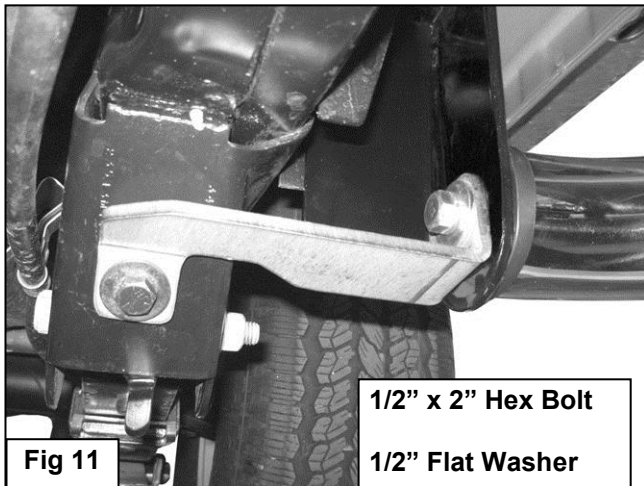
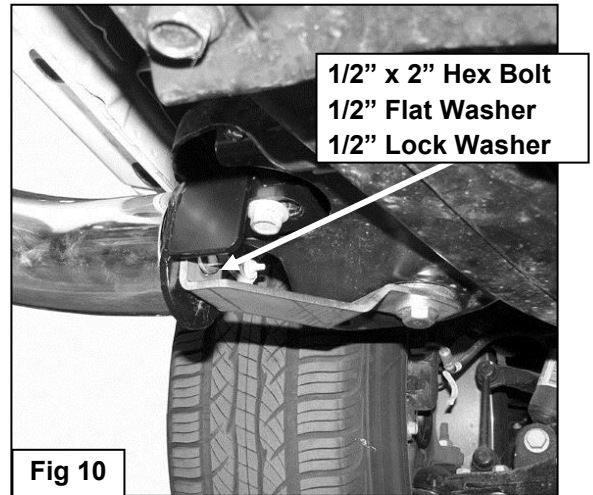
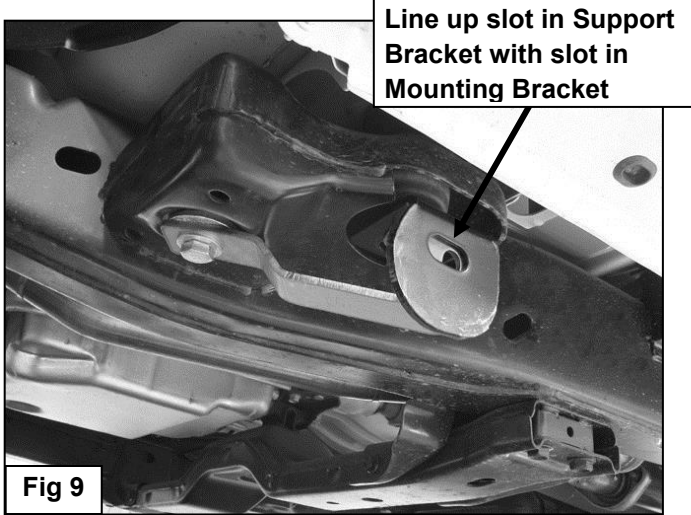

8. Adjust the Sidebar properly and then tighten all hardware.
9. Repeat steps 2 – 9 for passenger Sidebar installation.

PARTS IDENTIFICATION GUIDE

Driver Side tube packed using "Green" color foam sheet. Passenger Side tube packed using "White" color foam sheet

No.	Parts Identification
1	Passenger / Right 'Rear' Bracket marked "PR"
2	Driver / Left 'Rear' Bracket marked "DR"
3	Passenger / Right 'Center' Bracket marked "PC"
4	Driver / Left 'Center' Bracket marked "DC"
5	Passenger / Right 'Front' Bracket marked "PF"
6	Driver / Left 'Front' Bracket marked "DF"

Note:

- This guide is to identify the parts and not a reference for part count.
- Product / Bracket image is for representative purpose only.
- Actual design may vary based on application.
- Refer Installation Instructions for Hardware Kit detail.

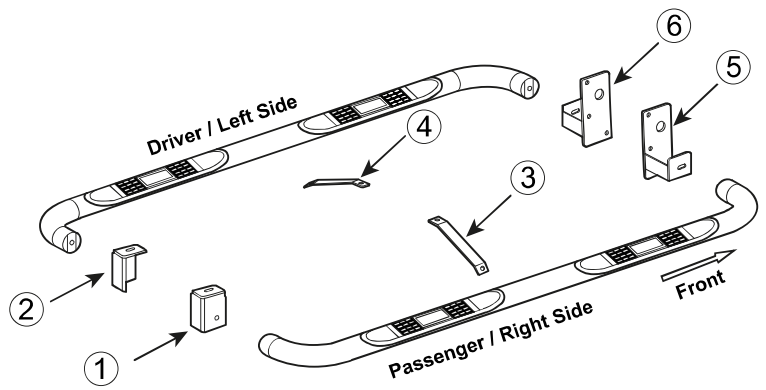

PRODUCT CARE

- Periodically check the product to ensure all fasteners are tight and components are intact.
- Regular waxing is recommended to protect the finish of the product.
- **Use ONLY Non-Abrasive automotive wax.** Use of any soap, polish or wax that contains an abrasive is detrimental and can scratch the finish leading to corrosion.
- Aluminum polish may be used to polish small scratches and scuffs for **Stainless Steel finish.**
- Mild soap may be used to clean the product for both **Stainless Steel and Black finish.**

FAQ's

1. **Hardware's are not of correct size.**
In GMC / Chevrolet truck model 2006 & up, customer needs to reuse the factory body bolts to install the bracket. If your vehicle is not GMC / Chevrolet 2006 & up, please ensure that holes are not partially covered with any plastic grommet or rust? If it is, please remove the plastic grommet & rust from the thread holes & re-try the installation.
2. **Mounting Bracket are not getting Installed properly.**
In some cases Illustration images shown in Installation manual may not be the exactly same as per actual vehicle images ,also if Driver / Passenger side mounting brackets are very identical in the design, suggest referring Parts Identification guide to avoid fitment issue.
3. **Products are thumping / rattling after installation.**
Please ensure that all required mounting brackets / hardware's are installed & tighten correctly. Suggest using white lithium / regular grease between the metal to metal contact surfaces.
4. **Side Bar is not aligning with vehicle / Step Pads are not aligning with vehicle doors.**
Side bar may be interchanged or mounting brackets are not installed at the correct position in the vehicle. Please refer Parts identification guide.
5. **Missing / Excess Hardware.**
Recheck hardware count as per the part list.
6. **Product not installing properly.**
Ensure make model year, cab length and bed size of your vehicle is listed in the application. All installation steps are followed correctly.