

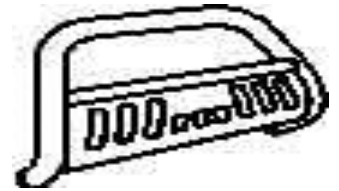

# 3" Bull Bar

## Part No. 1330371971/B0021B



Fits: 1997-2002 Ford Expedition 4WD  
 1999-2002 Ford Expedition 2WD  
 1999-2004 Ford F150/F250 LD 2WD (Heritage Edition; Excl. STX models)  
 1997-2004 Ford F150/F250 LD 4WD (Heritage Edition; Excl. STX models)  
 2001-2003 Ford F150 Super Crew



CUTTING OF THE AIR DAM MAY BE REQUIRED ON 2WD MODELS



REMOVE CONTENTS FROM BOX. VERIFY ALL PARTS ARE PRESENT.



READ INSTRUCTIONS CAREFULLY BEFORE STARTING INSTALLATION.

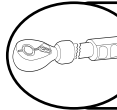

DO NOT OVER TORQUE. STANDARD OPERATING LOAD FOR TIGHTEN BODY MOUNT NUTS & BOLTS VARIES FROM 45 TO 65 FOOT POUND.



30-60 min



Cutting Required



Drilling Not Required



POLISHED STAINLESS STEEL – LIMITED LIFETIME  
 POWDER COATED BLACK – 3 YEARS

### PARTS LIST:

Qty	Part Description	Qty	Part Description
1	Bull Bar	2	12-1.75mm x 140mm Hex Head Bolts
1	Driver/Left Mounting Bracket	4	12-1.75mm x 35mm Hex Head Bolts
1	Passenger/Right Mounting Bracket	8	12mm Lock Washers
2	Square Washers	8	12mm Hex Nuts
2	12-1.75mm x 30mm Bolt Plates	14	12mm Flat Washers



Passenger Side Mounting Bracket



Driver Side Mounting Bracket

### INSTALLATION PROCEDURE:

**NOTE:** It may be necessary to remove/relocate front license plate and license plate bracket. It is not required, but strongly recommended. If local/state law requires a license plate, license plate relocation kit is available.

- NOTE:** Cutting the bottom of bumper is necessary if vehicles are not equipped with tow hooks.

#### Vehicles with Tow Hooks Instructions

- Starting on the driver side of the vehicle, remove tow hook by removing front bolt and loosening rear bolt sufficiently. **IMPORTANT!** Do not remove rear bolt completely. Once you remove the front bolt and loosen up the rear bolt, push back on the tow hook to disengage it from rear bolt. Tow hooks can be re-installed if desired (**Figure 1**).

- Position Mounting Bracket on the inside of frame rail and secure the rear of Bracket to frame using the included (1) 12mm x 140mm Hex Head Bolt, (1) 12mm Lock Washer, (1) 12mm Hex Nut, (2) 12mm Flat Washers, and (1) Square Washer (**Figure 2 & 3**). **NOTE:** Place Square Washer on the outer side of frame.

**(Driver Side Installation Without Tow Hooks Shown)**

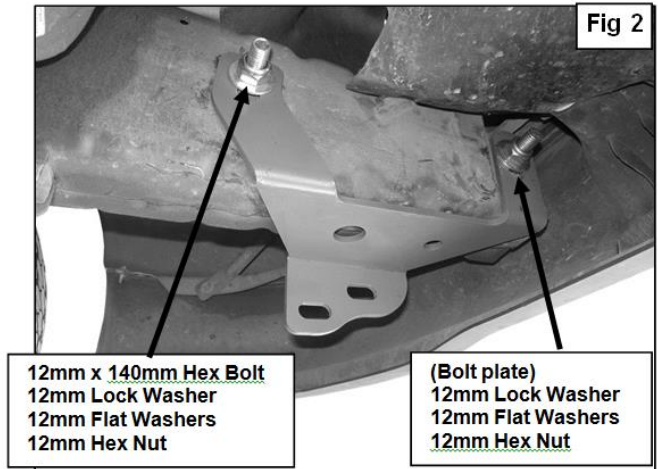
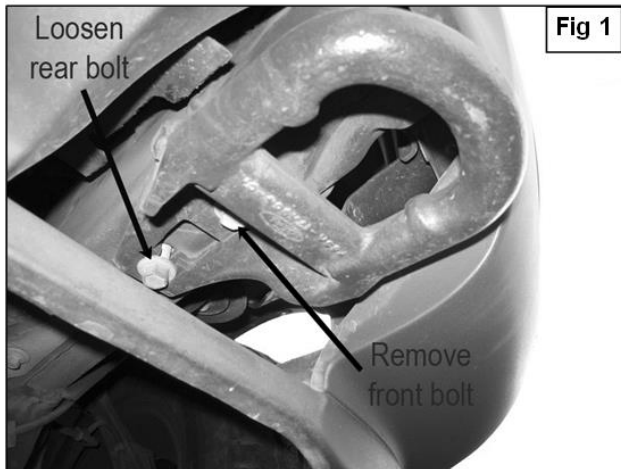

- Insert one of the Bolt Plates through front end of frame rail and orient bolt to push through inside front round hole in the frame rail side.
- Attach the front end of Bracket to Bolt Plate using the included (1) 12mm Hex Nut, (1) 12mm Lock Washer, and (1) 12mm Flat Washer (**Figure 2**).
- Position factory tow hook over Mounting Bracket and re-install tow hook back to the vehicle using the factory hardware.
- Repeat **steps 3 – 7** for opposite side. **NOTE:** Installation shown without tow hook.
- Position Bull Bar on the outer side of Mounting Brackets. Use the included (4) 12mm x 35mm Hex Head Bolts, (4) 12mm Lock Washers, (4) Hex Nuts, and (8) 12mm Flat Washers (**Figure 6**).

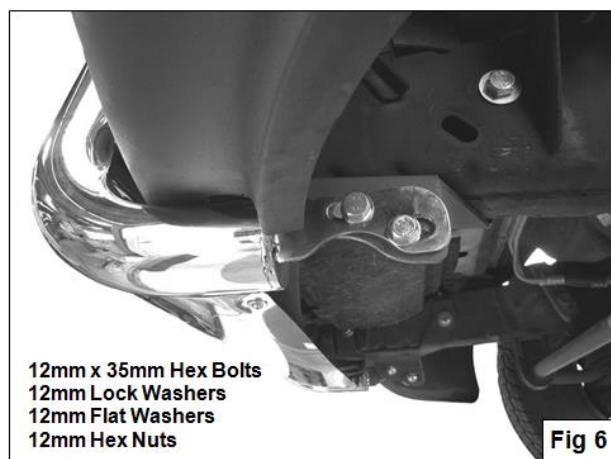
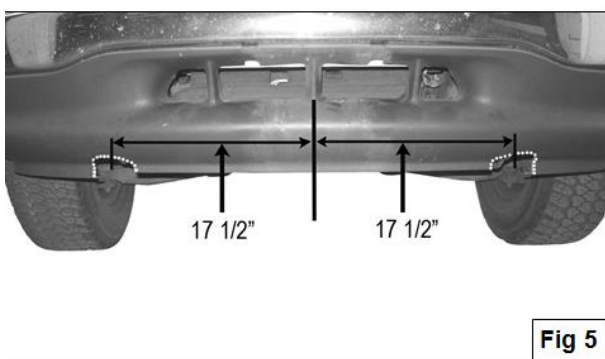
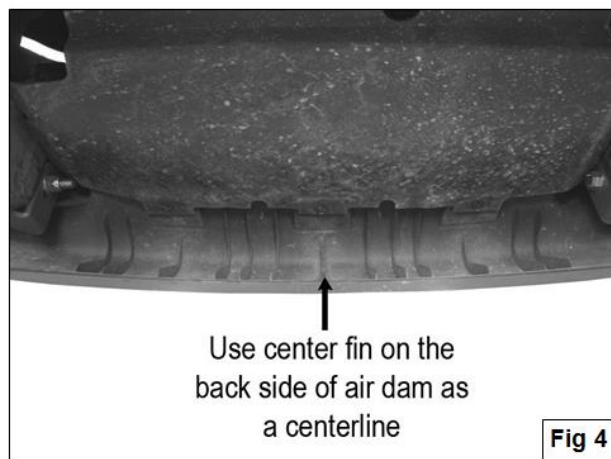
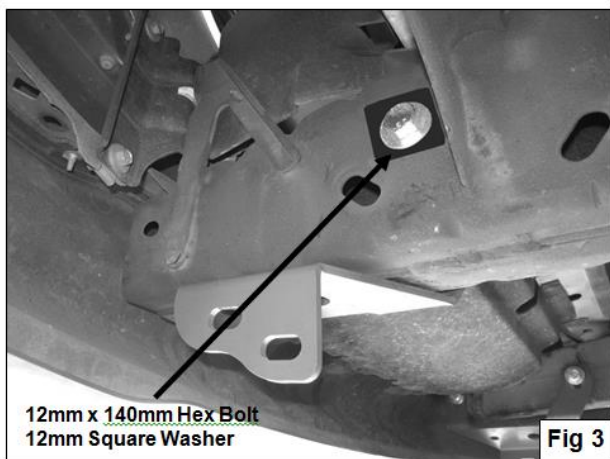

### **Vehicles without Tow Hooks Instructions**

9. Mark the centerline of lower air dam by locating the series of small fins on the backside of air dam. Locate the center small fin and use it as a centerline (**Figure 4**), measure and mark a line 17 ½" from center line to each side of the air dam (**Figure 5**).  
**NOTE:** Do not follow contour of air dam.
10. Cut a 3" diameter round hole on each marked location, 2" from the bottom of bumper and then trim to a "U" shaped cavity.
11. Starting on the driver side of the vehicle, position Mounting Bracket on the inside of frame rail and secure the rear of Bracket to frame using the included (1) 12mm x 140mm Hex Head Bolt, (1) 12mm Lock Washer, (1) 12mm Hex Nut, (2) 12mm Flat Washers, and (1) Square Washer (**Figure 2 & 3**). **NOTE:** Place Square Washer on the outer side of frame.
12. Insert one of the Bolt Plates through front end of frame rail and orient bolt to push through inside front round hole in the frame rail side.
13. Attach the front end of Bracket to Bolt Plate using the included (1) 12mm Hex Nut, (1) 12mm Lock Washer, and (1) 12mm Flat Washer (**Figure 2**).
14. Repeat **steps 12 - 14** for opposite side.
15. Position Bull Bar on the outer side of Mounting Brackets. Use the included (4) 12mm x 35mm Hex Head Bolts, (4) 12mm Lock Washers, (4) Hex Nuts, and (8) 12mm Flat Washers (**Figure 6**).
16. Align Bull Bar properly, and then tighten all hardware at this time.

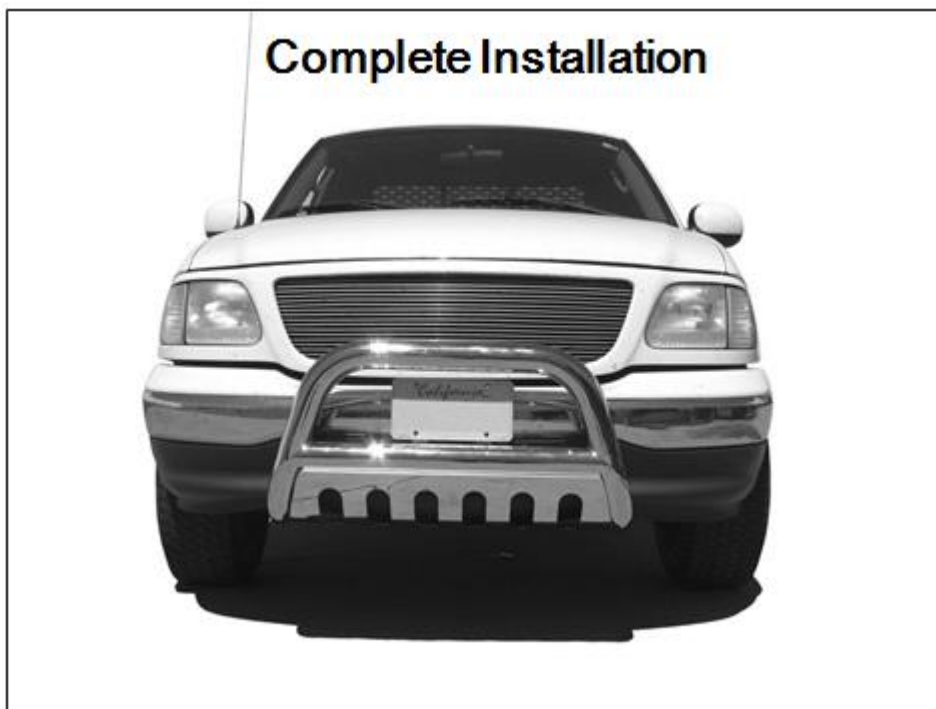

## PRODUCT CARE

- Periodically check the product to ensure all fasteners are tight and components are intact.
- Regular waxing is recommended to protect the finish of the product.
- **Use ONLY Non-Abrasive automotive wax.** Use of any soap, polish or wax that contains an abrasive is detrimental and can scratch the finish leading to corrosion.
- Aluminum polish may be used to polish small scratches and scuffs for **Stainless Steel finish.**
- Mild soap may be used to clean the product for both **Stainless Steel and Black finish.**

## FAQ's

**1. Hardware's are not of correct size.**

*In GMC / Chevrolet truck model 2006 & up, customer needs to reuse the factory body bolts to install the bracket. If your vehicle is not GMC / Chevrolet 2006 & up, ensure that holes are not partially covered with any plastic grommet or rust? If it is, remove the plastic grommet & rust from the thread holes & re-try the installation.*

**2. Mounting Bracket are not getting Installed properly.**

*In some cases Illustration images shown in Installation manual may not be the exactly same as per actual vehicle images ,also if Driver / Passenger side mounting brackets are very identical in the design, suggest referring Parts Identification guide to avoid fitment issue.*

**3. Products are thumping / rattling after installation.**

*Ensure that all required mounting brackets / hardware's are installed & tighten correctly. Suggest using white lithium / regular grease between the metal to metal contact surfaces.*

**4. Side Bar is not aligning with vehicle / Step Pads are not aligning with vehicle doors.**

*Side bar may be interchanged or mounting brackets are not installed at the correct position in the vehicle. Refer Parts identification guide.*

**5. Missing / Excess Hardware.**

*Recheck hardware count as per the part list.*

**6. Product not installing properly.**

*Ensure make model year, cab length and bed size of your vehicle is listed in the application. All installation steps are followed correctly.*



**SIDE BARS**



**ROCKER GUARD**

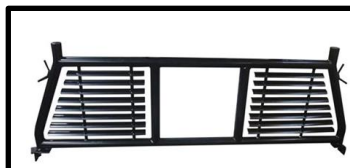

**HEADACHE RACKS**



**RUNNING BOARDS**

Keystone Automotive Operations Inc. (KAO) warrants this product to be free of defects in material and workmanship at the time of purchase by the original retail consumer. KAO disclaims any other warranties, express or implied, including the warranty of fitness for a particular purpose or an intended use. If the product is found to be defective, KAO may replace or repair the product at our option, when the product is returned prepaid, with proof of purchase. Alteration to, improper installation, or misuse of this product voids the warranty. KAO's liability is limited to repair or replacement of products found to be defective, and specifically excludes liability for any incidental or consequential loss or damage.