



## TOOLBOX MOUNT INSTALLATION

SKU# 25200

*The ToolBox Mount Kit is designed to allow you to integrate your toolbox to the TracRac Base Rails:*

- *Mount your toolbox without drilling, bolting or damaging your truck.*
- *Slide your toolbox back to the tailgate for easy access.*
- *Painlessly remove your toolbox from the truck, for greater cargo carrying capacity.*

*Note: We design the TracRac system to accommodate most style toolboxes. Check to confirm that the belly of the box fits between the baserails (on most trucks, the width of the belly needs to be 61" or less.)*

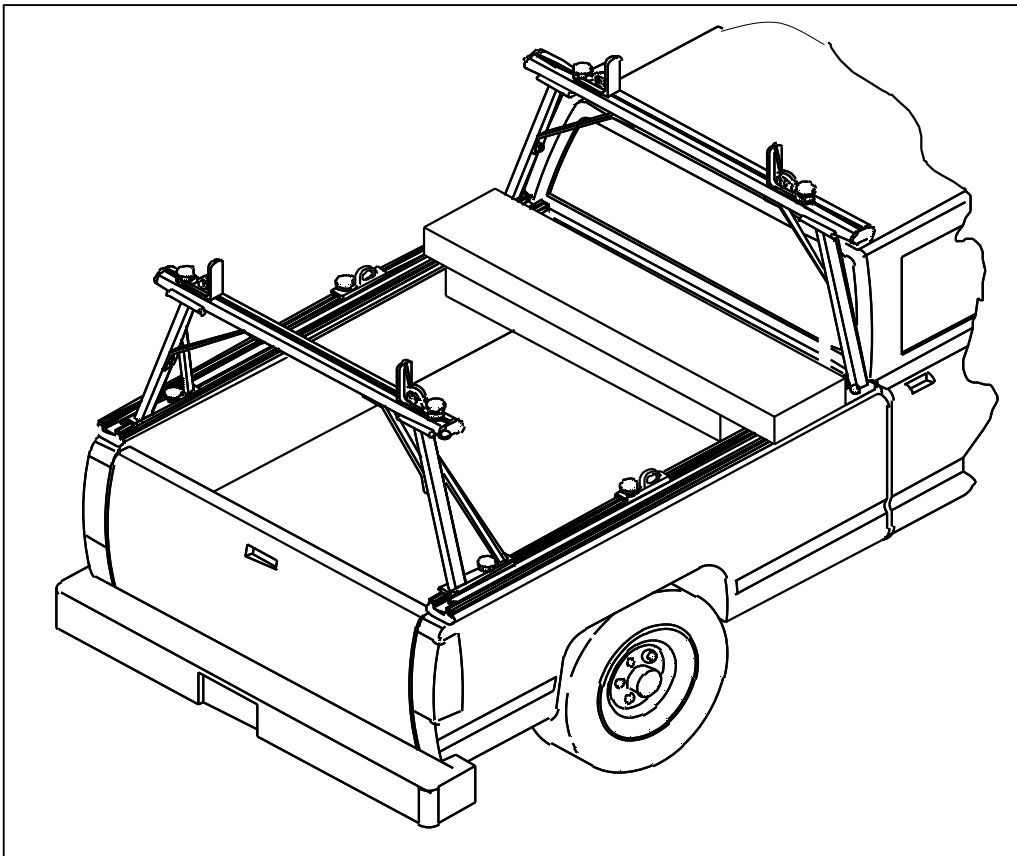

### **Tools Required**

- 1) Tape Measure
- 2) Power Drill
- 3) 1/8" Drill Bit
- 4) 1/2" Drill Bit
- 5) Socket Wrench
- 6) 9/16" Socket
- 7) 3/16" Allen Wrench
- 8) 1/4" Allen Wrench
- 9) Felt Tip Marker

### **Recommended**

- 1) Torque Wrench

- 1) Verify that you have received the correct parts, using the attached Assembly Drawing and Packing Checklist.
- 2) Replace the knobs in the forward racks with the 1/2" x 1/2" Set Screws w/ Nylon Tip supplied with ToolBox Mount assembly. (This allows the toolbox to fit directly behind the overhead racks!)



- 3) Your goal is to position the Mount Kit beneath your toolbox in the correct location, so the box can be mounted to the Base Rails. Start by measuring the width between the Base Rail inner T-Tracks. (See Fig 1) Hook the tape measure on the outer edge of the driver's side inner T-Track and measure to the innermost edge of the passenger side T-Track (this is Measurement **A**: mark it down below).

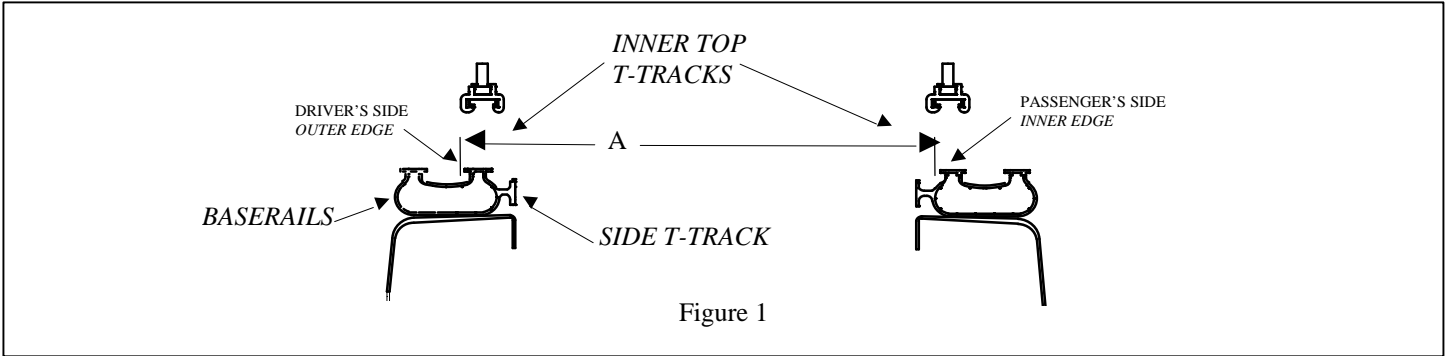

- 4) Take your toolbox and measure the width of the box's belly (Measurement **B**) (See Fig 2)

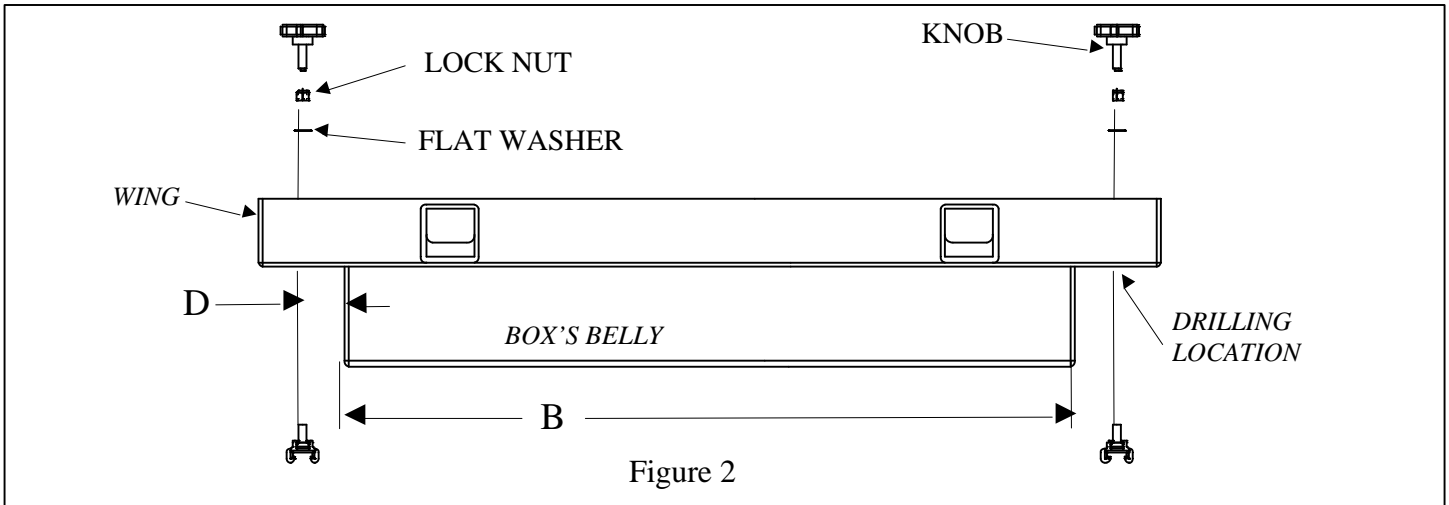

- 5) Use the chart in Figure 2a to calculate where to drill the holes in your toolbox.  
6) **A minus B equals C & C divided by 2 equals D**



- 7) Flip the box upside down and mark off distance **D** from the edge of the box's belly at the front and rear edge of the toolbox wing. (Figure 3) Repeat for the opposite side. Connect the marks with a straight edge, and scribe a line. This line is the *drilling centerline*.
- 8) You will be drilling the mounting holes on the centerlines from Step 6. Before drilling, double-check your accuracy by measuring between centerlines. *The distance should match Measurement A. (If not, repeat the process to obtain A, B, and C.)*
- 9) Before drilling the mounting holes, check the inside of your toolbox for the handle locations. If your toolbox's handles are on the sides, drill the knob access holes away from handles. The Toolbox Mounts are designed with an alternate hole for the Knobs. This allows you to move the knob 4" off center to make room for the handles.
- 10) Drill a 1/2" diameter hole for the knob at the midpoint (or 4" from the midpoint) of the centerline on the toolbox wing. Drill two 1/2" diameter holes along the same line, on each side of the center hole, approx. 6" from midpoint of the centerline. Repeat for the other side. (Note: Use a 1/8" drill bit for an accurate pilot hole)
- 11) Slide the Slider Stops onto the inner Top T-Track, one on each side. Slide them to the front, cab-end of the Base Rails.

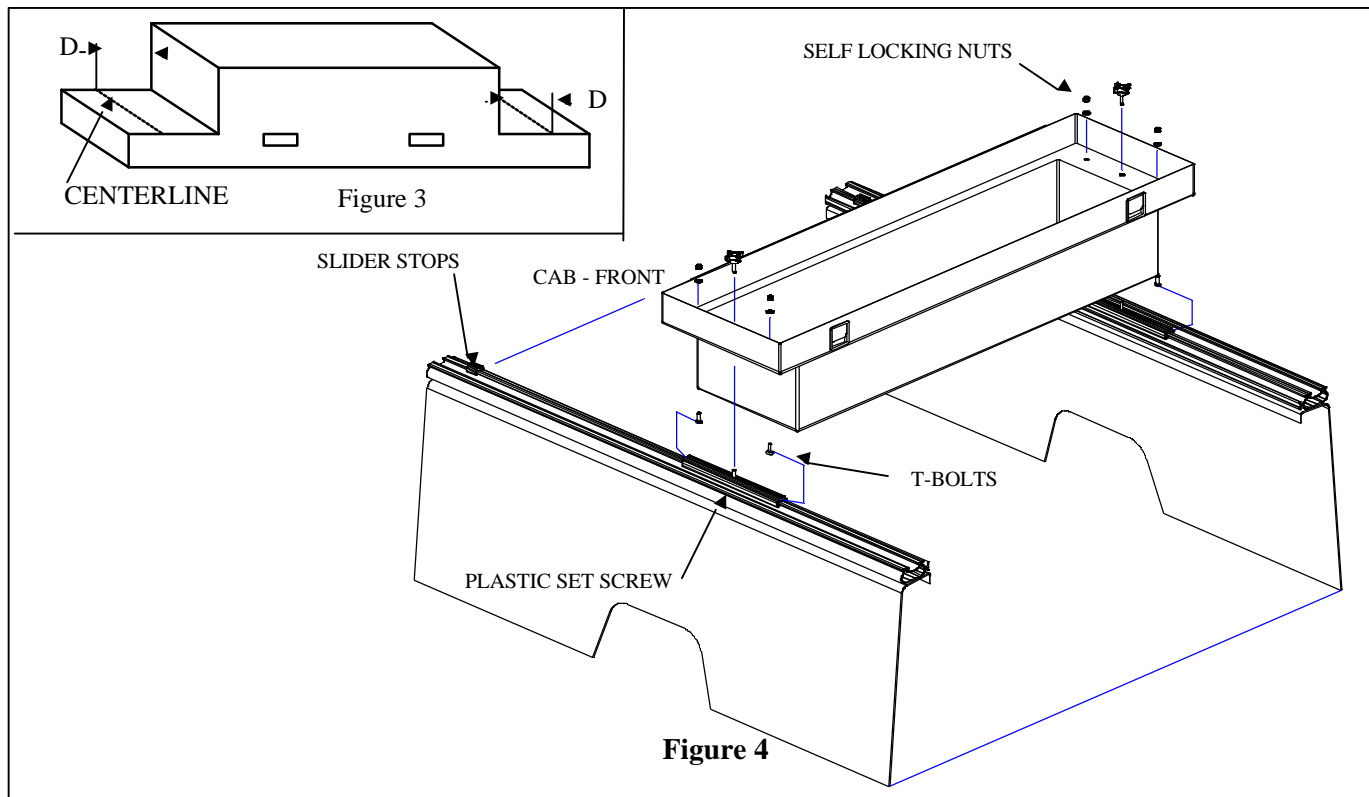

- 12) Slide the Toolbox Mounts onto the inner Top T-Track of each Base Rail, approximately 24" from tailgate. Starting with the driver's side, insert the Square Nut into the Slider's Top Slot, and position it over the selected hole for the Knob. (see step 8) Thread the 1" Plastic Set Screw through the Nut into the Slider. (**Do not bottom out screw into Base Rail.**) Repeat on passenger side. (Figure 4)



- 13) Insert 2 T-Bolts into the slot on each slider, one from each end. Slide the T-Bolts so that each is 6" from the plastic set screw.

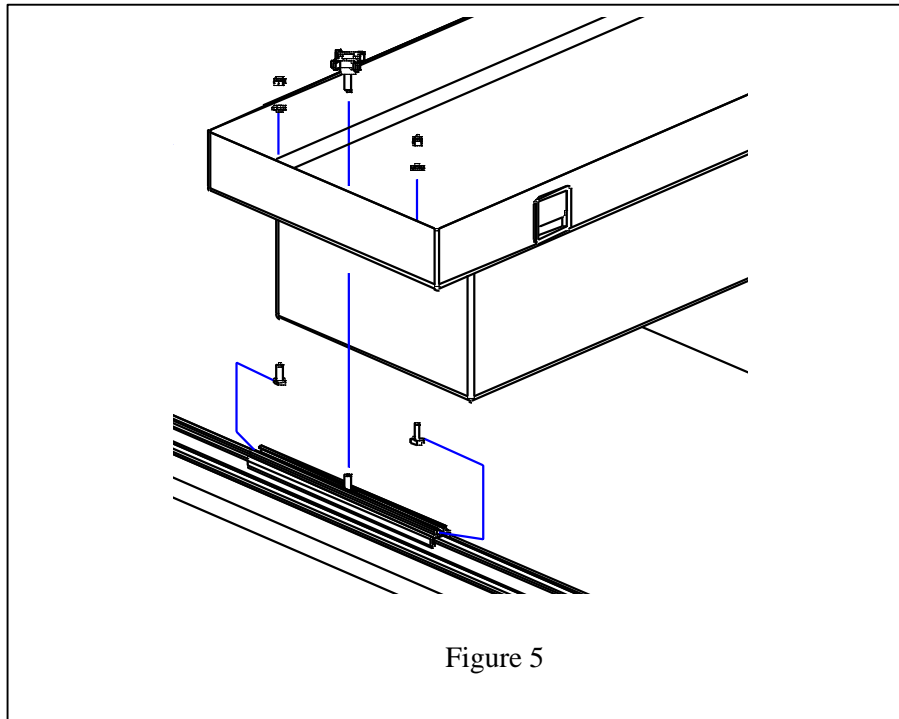

- 14) Now mount the toolbox, making sure the Plastic Set Screws and T-Bolts protrude through the six holes in your toolbox.
- 15) Remove Plastic Set Screws from assembly and **immediately** replace with the Knobs. Fasten the toolbox to the sliders with the T-Bolts (*in sliders*), Flat Washers and Self Locking Nuts to the specified Torque of 240 in/lbs. (20 ft/lbs.).
- 16) Now slide the toolbox the length of the Base Rails for final verification. **Note: If the toolbox does not slide, recheck that the Base Rails and Toolbox Mount Sliders are parallel, and that the toolbox is centered.**
- 17) Slide the toolbox towards the cab, making sure you allow clearance to open the lid. Position the Slider Stops under the toolbox until they butt up against the Toolbox Mounts. Pull the toolbox back and tighten the Set Screws in the Slider Stops. (*The Slider Stops will prevent the toolbox from sliding into the Overhead Racks.*)
- 18) Slide the toolbox up until it butts against the Slider Stops and tighten the toolbox Knobs.

**Note:** The beds of some newer model trucks taper dramatically, impeding your ability to slide the toolbox entirely off the tailgate. We recommend utilizing a toolbox with a narrow belly. Measure the width at your truck's tailgate to determine the maximum width of your truck bed.

**CAUTION:** Always make sure the knobs are tightened down to prevent the toolbox from sliding. Be sure to tighten down the safety screws on the front and rear of the base rails as well.