

# Installation Instructions

## Trailer Tow Harness

### READ THIS FIRST:

Read and follow all instructions carefully before beginning installation.

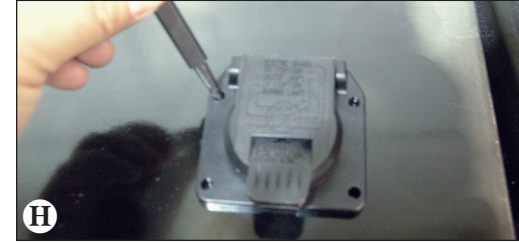
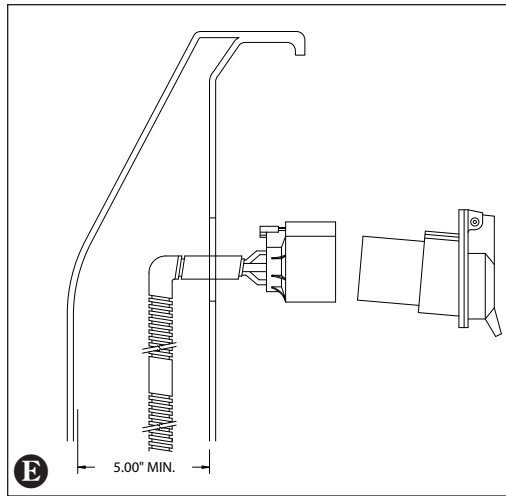
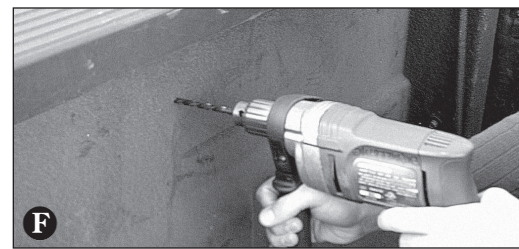

### ENGLISH

#### TOOLS NEEDED: 7-WAY INSTALL

Drill (3/32" & 1/4" Drill Bits), 2" Hole Saw, Philips Head Screwdriver, Center Punch and Hammer

#### TOOLS NEEDED: 6-WAY INSTALL

Drill (3/32" & 1/4" Drill Bits), 1-3/8" Hole Saw, Philips Head Screwdriver, Center Punch and Hammer

1. Locate the vehicle's 7-way factory harness on or near the rear bumper. **A** Separate this connector, being careful not to break the locking tabs. **B** Ensure that the mating surfaces are free of dirt. Clean if necessary. Install the Trailer Tow Harness between the mating plugs.
2. Determine a suitable mounting point (usually on the Driver's side, Forward of the wheel well area in the Bed) then route the harness to this location. **C** **D** During routing, make sure you have some extra length (approximately 4" or more) that will be needed in step 5.
  - ⚠ WARNING**  
When routing the wire harness be careful to avoid any hot pipes, heat shields, the fuel tank and fuel tank filler tube or any other points that may pinch or break the wire.
  - 📌 NOTE**  
Cut away view of truck rail. Make sure there is at least 5" of clearance for mounting.
3. **⚠ CAUTION**  
Verify what is behind any surface prior to drilling to avoid damage to the vehicle and/or personal injury. Do not drill into any exposed surfaces.  
Once a suitable mounting location is found, center punch then drill a pilot hole using a drill and 1/4" bit. **F**

Re-check your mounting location and wire lengths and then drill a hole use your hole saw to finish cutting the mounting hole. **G**

Using the Connector end as a guide, mark the mounting hole locations with a center punch **H** and then drill four 3/32" holes (7-Way) and two 3/32" holes (6-way) as marked.

**NOTE**  
If the vehicle has a bedliner it will need to be notched or use a longer set of screws (not provided) and mount directly into the bedliner and body panel.

**NOTE**  
Use rust-proof coating in drilled areas to prevent future rusting (not provided).

4. Before mounting connector housing to truck bed, wire connector per chart **K** **L**. Route harness thru mounting hole and connect the 6 or 7-way end to the harness. **I** **J**
5. **⚠ WARNING**  
All connections must be complete for the Trailer Tow Harness to function properly. Using the self-tapping screws, mount the Connector harness to the vehicle surface. Test and verify installation with a test light or trailer once installed.  
**NOTE**  
On some vehicles you may need to add a fuse or relay (not provided) to complete all of the functions going to the 6 or 7-way connector. Consult your owner's manual for locations.
6. Secure the harness to the vehicle, using the cable ties provided.
  - ⚠ WARNING**  
Route the wire being careful to avoid any hot pipes, heat shields, the fuel tank or any other points that may pinch or break the wire.

