

**HD2 WINCH FRONT BUMPER
2015-17 FORD F150
(EXCLUDES "LIMITED" MODEL)**

PARTS LIST:

1	HD2 Front Bumper	20	12mm x 37mm OD x 3mm Flat Washers
1	Winch Tray Assembly	14	12mm Lock Washers
1	Bull Nose Hoop	10	12mm Hex Nuts
1	Winch Cover Plate	2	10-1.5mm x 30mm Button Head Bolts
1	Driver/Left Support Bracket	4	10mm x 20mm x 2mm Flat Washers
1	Passenger/Right Support Bracket	2	10mm Nylon Lock Nuts
1	Driver/left Outer Mesh Plate	8	8-1.25mm x 25mm Button Head Bolts
1	Passenger/right Outer Mesh Plate	2	8-1.25mm x 25mm Hex Bolts
1	Driver/left LED "L" Bracket	2	8-1.25mm x 16mm Hex Bolts
1	Passenger/right LED "L" Bracket	18	8mm x 24mm x 2mm Flat Washers
1	Pivot License Plate Bracket	12	8mm Lock Washers
2	Plastic Plugs for license plate mount	6	8mm Hex Nuts
2	12mm Double Bolt Plates	4	6-1.0mm x 20mm Combo Bolts
2	12mm Double Nut Plates	4	6mm Flange Nuts
10	12mm Plastic Retainers	1	5mm Wrench
4	12-1.75mm x 50mm Hex Bolts	1	4mm Wrench
6	12-1.75mm x 40mm Hex Bolts	10	Plastic Wire Ties

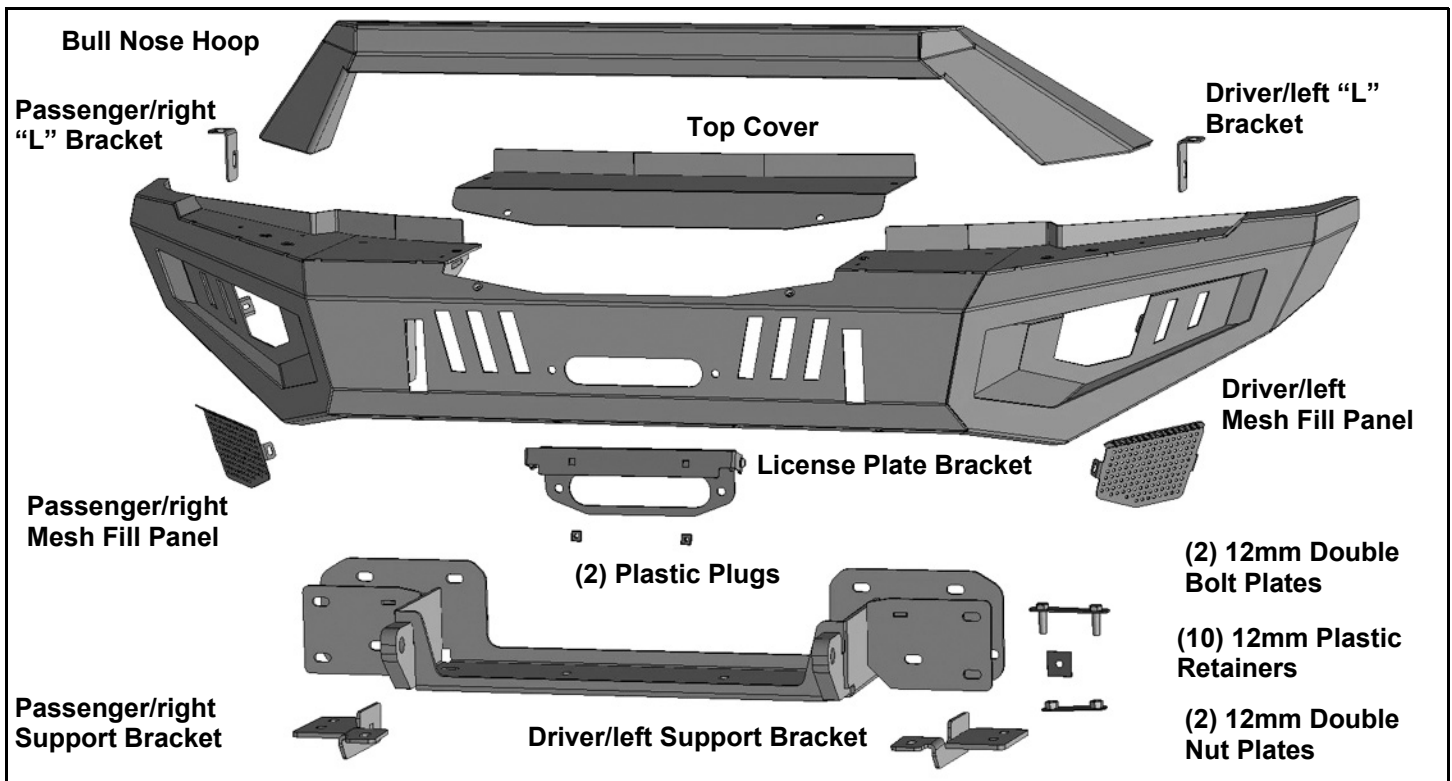

PROCEDURE: REMOVE CONTENTS FROM BOX. VERIFY ALL PARTS ARE PRESENT. READ INSTRUCTIONS CAREFULLY BEFORE STARTING INSTALLATION. BUMPER IS HEAVY, ASSISTANCE IS HIGHLY RECOMMENDED TO AVOID POSSIBLE INJURY OR DAMAGE TO THE VEHICLE.

1. Remove the license plate and bracket, **(Figure 1)**. Remove the plastic bumper pad assembly, **(Figure 2)**. **NOTE:** Carefully pull bumper pad straight out away from bumper. Unplug and remove the adaptive cruise control, if equipped, **(Figure 3)**.
2. Unplug the fog lights, if equipped, **(Figure 4)**. Release the wiring harness from the clips attached to the back of the bumper. Move all wiring harnesses away from bumper.

**HD2 WINCH FRONT BUMPER
2015-17 FORD F150
(EXCLUDES "LIMITED" MODEL)**

3. Place blocks or jack stands under the front bumper to support it during mounting bolt removal. Once the bumper has been safely supported, remove the large hex nut, (1 per side), from the back of the bumper bracket attaching the lower bumper to the bumper bracket, **(Figure 5)**. Next, from the front of the bumper, remove the (2) factory hex nuts attaching the bumper to the bumper brackets, **(Figure 6)**. **WARNING!** Assistance is required to hold the bumper in place during bolt removal to prevent the bumper from falling. Carefully slide the bumper off over the tow hooks if equipped.
4. Remove the tow hooks and factory double bolt plates from the end of the frame, **(Figures 7 & 8)**. **NOTE:** Tow hooks cannot be reinstalled.
5. Carefully unwrap the Winch Tray Bracket Assembly. On models equipped with turbo, remove the shroud from the intercooler to clear the Winch Tray.
6. Select (1) factory double bolt plate, **(Figure 8)**. Insert the bolt plate through the top (2) mounting slots in the Winch Tray, **(Figure 9)**. Thread (2) 12mm Plastic Retainers onto the double bolt plate and up tight against the mounting plate to secure in place, **(Figure 10)**. **NOTE:** The Plastic Retainers are used to hold the bolt plates in place and help in Bumper installation. Use is optional. Repeat this Step to install the remaining factory bolt plate on the passenger/right side of the Winch Tray.
7. With assistance, hold the Winch Tray up to the end of the frame. Reuse the (4) factory hex nuts to attach the Winch Tray to the top of the frame and double nut plates, **(Figure 10)**. Attach the bottom of the Winch Tray to the lower mounting holes with the included (2) 12mm x 40mm Hex Bolts, (4) 12mm Flat Washers, (2) 12mm Lock Washers and (2) 12mm Hex Nuts, **(Figures 9 & 10)**. Snug but do not fully tighten the hardware.
8. Insert (1) 12mm Double Nut Plate into the open end of the frame, **(Figures 11 & 12)**. Line up the Nut Plate with the holes in the bottom of the frame. **NOTE:** On models with tow hooks, use the factory nut plate in the frame or the included Nut Plate.
9. Select the driver/left lower Support Bracket, **(Figure 12)**. Attach the Bracket to the bottom of the frame and double nut plate with the included (2) 12mm x 50mm Hex Bolts, (2) 12mm Lock Washers and (2) 12mm Flat Washers. Attach the Bracket to the bottom of the Winch Tray with (1) 12mm x 40mm Hex Bolt, (2) 12mm Flat Washers, (1) 12mm Lock Washer and (1) 12mm Hex Nut, **(Figures 12 & 13)**.
10. Repeat **Steps 8 & 9** to install the passenger/right Support Bracket.
11. If installing winch, (winch not included), attach the winch to the Winch Tray at this time. Winch must be installed before Bumper is placed in position. Follow manufacturer's instructions to install winch.
12. Carefully unwrap the Bumper assembly.
13. Determine if Bull Nose Hoop and bar style LED light will be installed, (installation is optional).

Attach Bull Nose Hoop

- a. Remove the rubber plugs from the top of the HD1 Bumper, **(Figure 14)**.
- b. Select the Bull Nose Hoop. Attach the Hoop to the top of the Bumper with the included (4) 8mm x 25mm Button Head Bolts, (8) 8mm Flat Washers, (4) 8mm Lock Washers and (4) 8mm Hex Nuts, **(Figure 15)**. Fully tighten Hoop hardware.

Attach bar style LED light, (light not included, installation is optional).

- a. Select the driver/left "L" Light Bracket. Attach the Bracket to the Hoop with (1) 8mm x 25mm Hex Bolt, (2) 8mm Flat Washers, (1) 8mm Lock Washer and (1) 8mm Hex Nut, **(Figure 16)**. Do not tighten hardware at this time.
- b. Repeat previous Step to attach the passenger/right "L" Bracket.
- a. Select the light, (not included). Attach light to Brackets with (2) 8mm x 16mm Hex Bolts, (2) 8mm Lock Washers and (2) 2 8mm Flat Washers if necessary or use the hardware included with the light, **(Figure 16)**. Adjust the width of the Brackets to the light and fully tighten bracket hardware.

14. Attach winch cable guide, (not included), to front of Bumper. **NOTE:** On vehicles requiring front license plate, select the Pivoting License Plate Bracket, **(Figure 17)**. Use the included (2) 10mm x 30mm Button Head Bolts, (4) 10mm Flat Washers and (2) 10mm Nylon Lock Nuts to attach the Bracket alone or if installing winch, between the cable guide and the Bumper. Push the included (2) push-in Plastic Plugs into the square holes in the Bracket and reuse the factory hardware to attach the license plate to the Plastic Plugs, **(Figure 17)**.

**HD2 WINCH FRONT BUMPER
2015-17 FORD F150
(EXCLUDES "LIMITED" MODEL)**

15. Select (1) 12mm Double Bolt Plate and (2) 12mm Plastic Retainers. Insert the Bolt Plate into the back of the driver/left side mounting plate on the Bumper, **(Figure 18)**. Thread the (2) Plastic Retainers onto the threaded ends of the Bolt Plate. Select (1) 12mm x 40mm Hex Bolt and (1) 12mm Flat Washer. Insert the Hex Bolt with the Flat Washer into the lower mounting slot in the back of the Bumper. Thread (1) 12mm Retainer onto the Hex Bolt, **(Figure 18)**. **NOTE:** The Plastic Retainers are used to help hold the hardware in position to aid in Bumper installation. Use is not mandatory for installation. Repeat this **Step** to install the hardware on the passenger/right side of the Bumper.
16. With assistance, position the Bumper Assembly up to the mounting plates on the Hitch Tray Bracket assembly. Temporarily support the weight of the Bumper. **WARNING:** To avoid possible injury or damage to the vehicle, do not proceed until the bumper is fully and safely supported.
17. Attach the Bumper to the Hitch Tray with the included (6) 12mm Flat Washers, (6) 12mm Lock Washers and (6) 12mm Hex Nuts, **(Figures 19 & 20)**. Do not fully tighten hardware at this time.
18. Level and adjust the Bumper and fully tighten all hardware.
19. Determine if accessory lights, (not included), or Screen Fill Panels will be installed at this time.
Screen Fill Panel Installation (do not install fill panels if installing lights).
 - a. Select the driver/left Screen Fill Panel, **(Figure 21)**.
 - b. Attach Screen Fill Panel to the tabs on the inside of the Bumper with the included (2) 6mm Button Head Combo Bolts and (2) 6mm Flange Nuts, **(Figure 21)**. Fully tighten Fill Panel hardware at this time.
 - c. Repeat to install the passenger/right Panel.
- Outer LED cube style light installation, (lights not included-do not install with Fill Panels).**
 - a. Attach lights to the mounting tabs on the back of the Bumper, **(Figure 21)**.
 - b. Follow the light manufacturer's instruction to properly wire lights once Bumper is installed.
20. Reuse the factory screws to attach the license plate if required.
21. On installations without winch or to cover winch, attach the top Bumper Cover Plate to the top of the Bumper with the included (4) 8mm x 25mm Button Head Bolts, (4) 8mm Lock Washers and (4) 8mm Flat Washers, **(Figure 22)**.
22. Do periodic inspections to the installation to make sure that all hardware is secure and tight.

To protect your investment, Do not use any type of polish or wax that may contain abrasives that could damage the finish. Mild soap may be used to clean the Bumper assembly.



(Fig 1) Remove license plate from Bumper

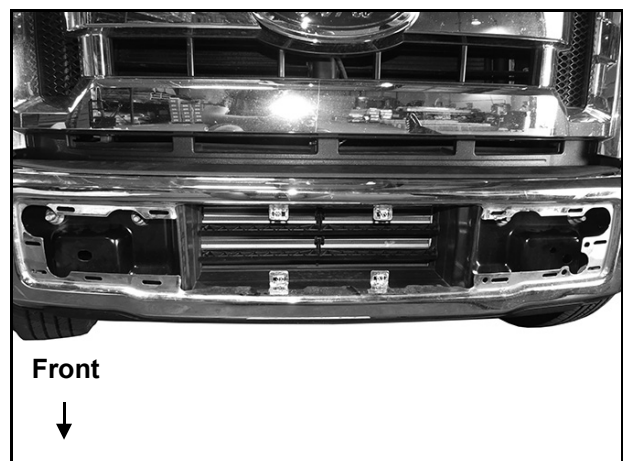

(Fig 2) Remove the plastic bumper pad from the front of the Bumper

Driver/left Side Installation Pictured

**HD2 WINCH FRONT BUMPER
2015-17 FORD F150
(EXCLUDES "LIMITED" MODEL)**

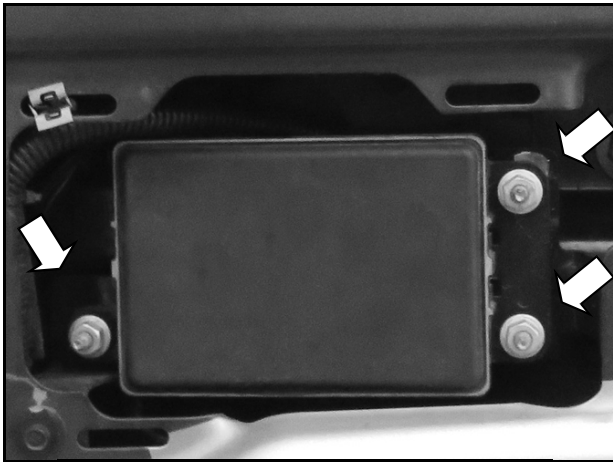

(Fig 3) Remove and unplug adaptive cruise control from driver/left side of frame, if equipped

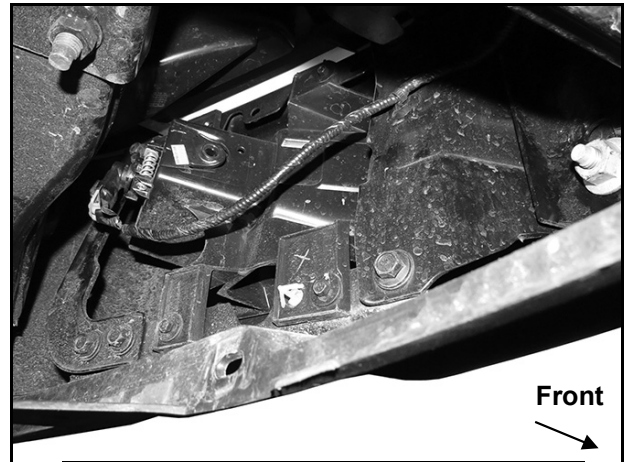

(Fig 4) Unplug and move factory wiring harness for fog lights (if equipped)

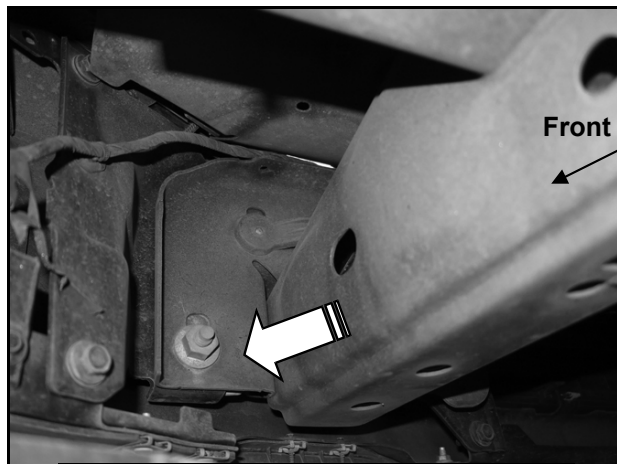

(Fig 5) Remove factory hex nut (arrow) from back of bumper bracket

WARNING! Do not remove bumper bolts unless the bumper is properly supported on blocks or stands or it may fall.

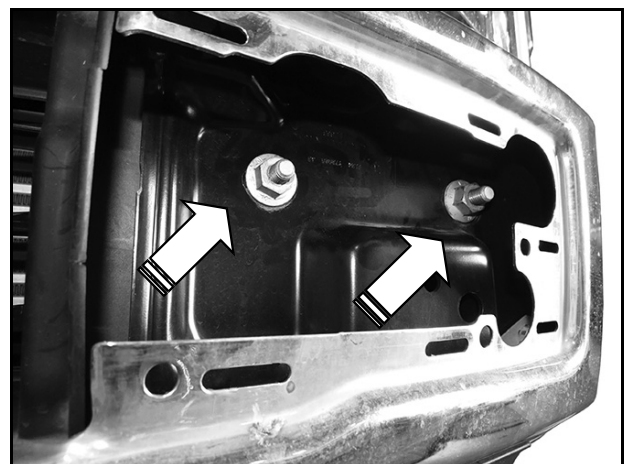

(Fig 6) Remove (2) factory hex nuts from each side

Driver/left Side Installation Pictured

**HD2 WINCH FRONT BUMPER
2015-17 FORD F150
(EXCLUDES "LIMITED" MODEL)**

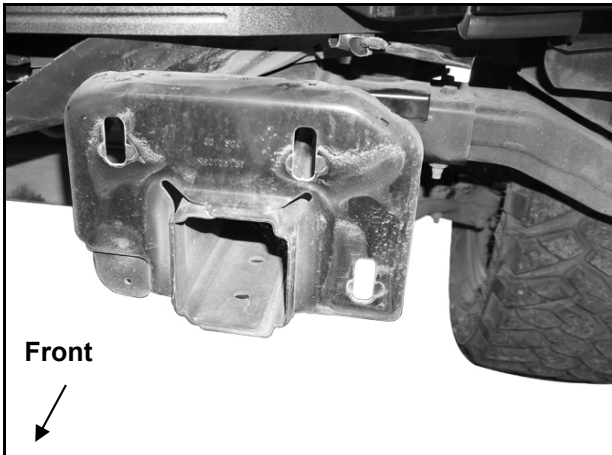

(Fig 7) Use a flat blade screwdriver to remove the clips and remove the double bolt plates from end of frame



(Fig 8) factory double bolt plate

(2) 12mm Plastic Retainers

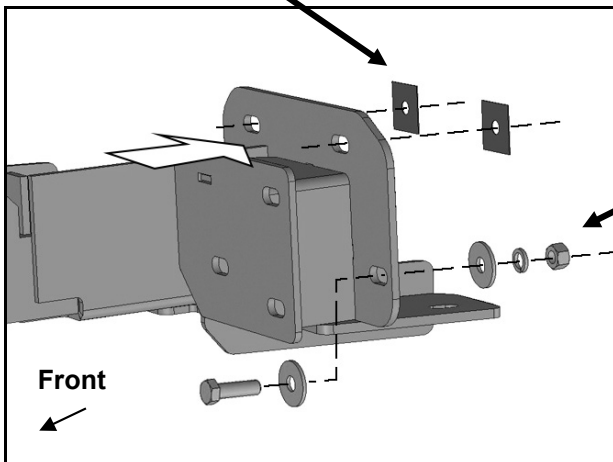

**Attach Winch Tray to bottom of frame
12mm x 40mm Hex Bolt
(2) 12mm Flat Washers
12mm Lock Washer
12mm Hex Nut**

(Fig 9) Insert the factory double bolt plate (fig 8) through the top mounting holes in the Winch Tray (arrow). Reuse factory hex nuts to attach Winch Tray to top of frame.

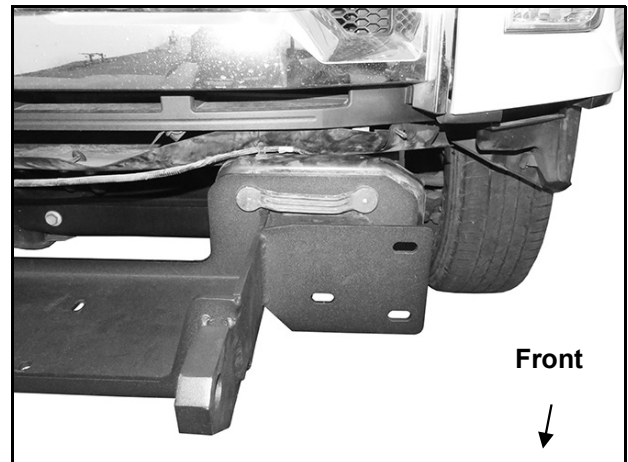

(Fig 10) Reuse double bolt plate and factory hex nuts to attach Winch Tray to top of frame.

Driver/left Side Installation Pictured

**HD2 WINCH FRONT BUMPER
2015-17 FORD F150
(EXCLUDES "LIMITED" MODEL)**



(Fig 11) Models without tow hooks, insert the included 12mm Double Nut Plate into open end of frame (arrow)

Attach Winch Tray Bracket to bottom of frame
 12mm x 40mm Hex Bolt
 (2) 12mm Flat Washers
 12mm Lock Washer
 12mm Hex Nut

12mm x 40mm Hex Bolt
 (2) 12mm Flat Washers
 12mm Lock Washer
 12mm Hex Nut

12mm Double Nut Plate

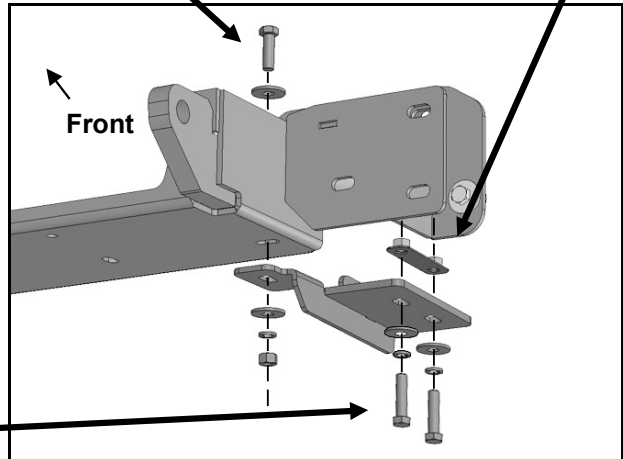

(2) 12mm x 50mm Hex Bolts
 (2) 12mm Lock Washers
 (2) 12mm Flat Washers

(Fig 12) Attach the driver/left Support Bracket to the 12mm Double Nut Plate in the frame and bottom of Winch Tray



(Fig 13) Driver/left Support Bracket installed

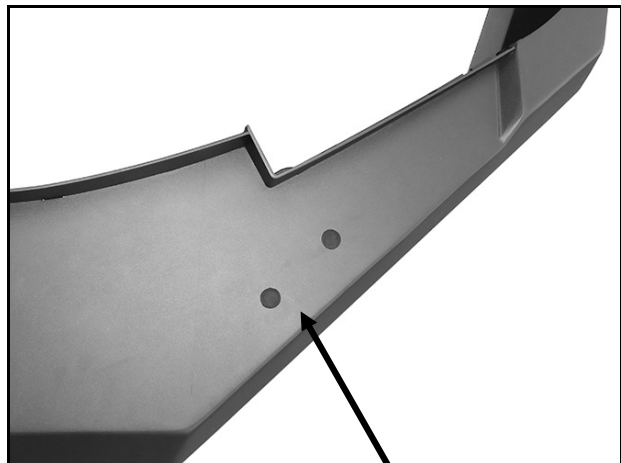

(Fig 14) Remove Rubber Plugs from top of Bumper to install Bull Nose Hoop

Driver/left Side Installation Pictured

**HD2 WINCH FRONT BUMPER
2015-17 FORD F150
(EXCLUDES "LIMITED" MODEL)**

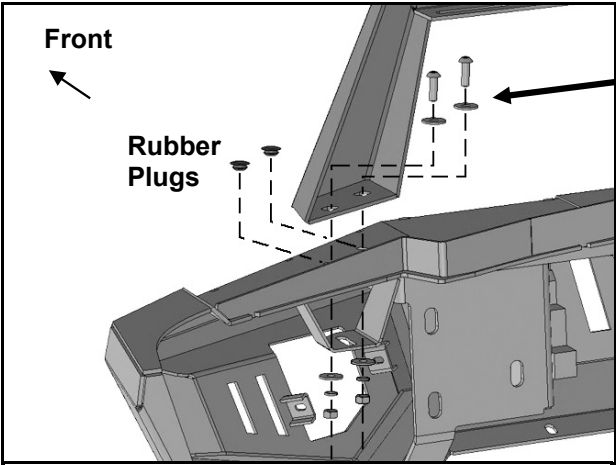

- (2) 8mm x 25mm Button Head Bolts
- (4) 8mm Flat Washers
- (2) 8mm Lock Washers
- (2) 8mm Hex Nuts

(Fig 15) Attach the Bull Nose Hoop to the top of the Bumper (driver/left side illustrated)

- 8mm x 16mm Hex Bolt
- 8mm Lock Washer
- 8mm Flat Washer
- 8mm x 25mm Hex Bolt
- (2) 8mm Flat Washers
- 8mm Lock Washer
- 8mm Hex Nut

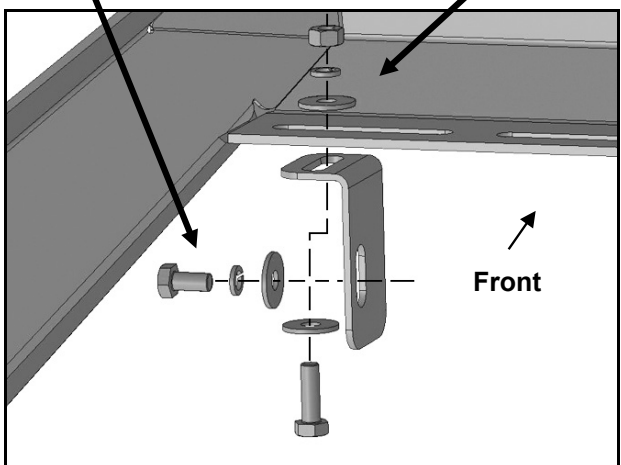

(Fig 16) Attach "L" LED Light Brackets to Bull Bar Hoop as desired (optional)

- (2) 10mm x 30mm Button Head Bolts
- (4) 10mm Flat Washers
- (2) 10mm Nylon Lock Nuts

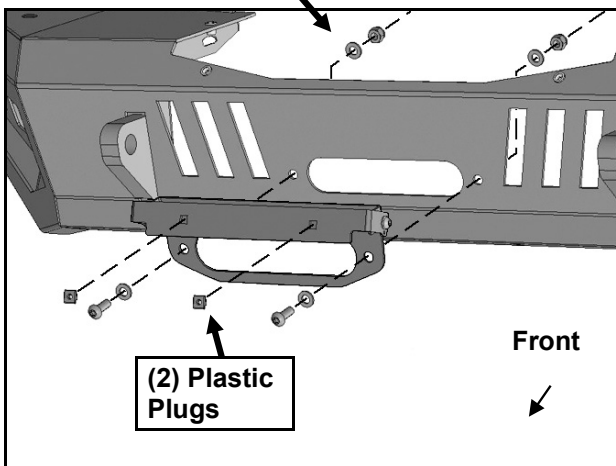

(Fig 17) Attach License Plate Bracket to Bumper if required. NOTE: Install Bracket between Bumper and winch cable guide

- (3) 12mm Plastic Retainers

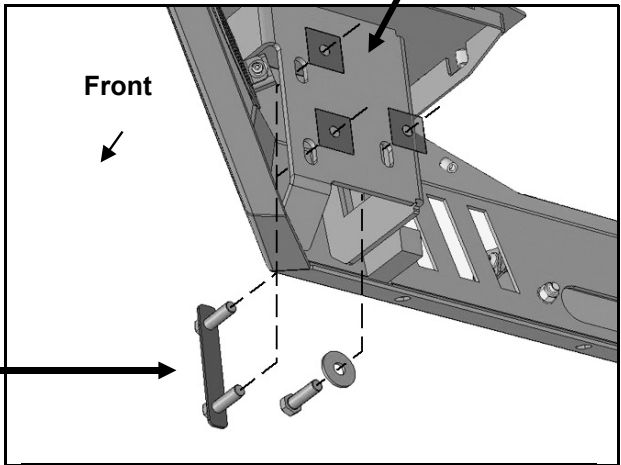

- 12mm Double Bolt Plate
- 12mm x 40mm Hex Bolt
- 12mm Flat Washer

(18) Use 12mm Plastic Retainers to hold 12mm Double Bolt Plate and Hex Bolt and Washer in place on back of Bumper

Driver/left Side Installation Pictured

**HD2 WINCH FRONT BUMPER
2015-17 FORD F150
(EXCLUDES "LIMITED" MODEL)**

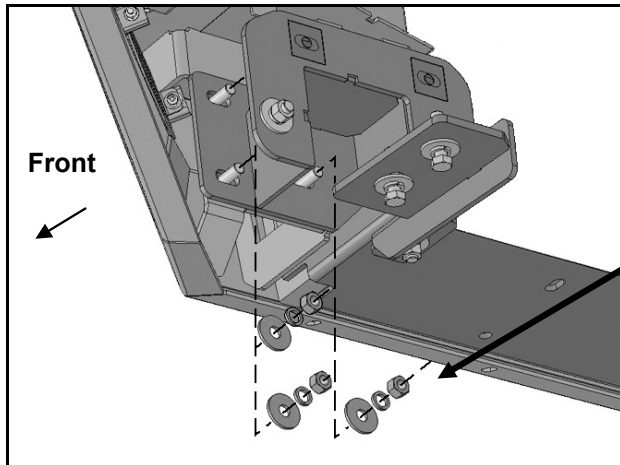

- (3) 12mm Flat Washers
- (3) 12mm Lock Washers
- (3) 12mm Hex Nuts

(19) Attach Bumper to Winch Tray Bracket assembly



**(20) Driver/left side of Bumper installed.
NOTE: Installation pictured without Support Bracket in place for instruction purposes only**

- (2) 6mm Combo Bolts
- (2) 6mm Flange Nuts

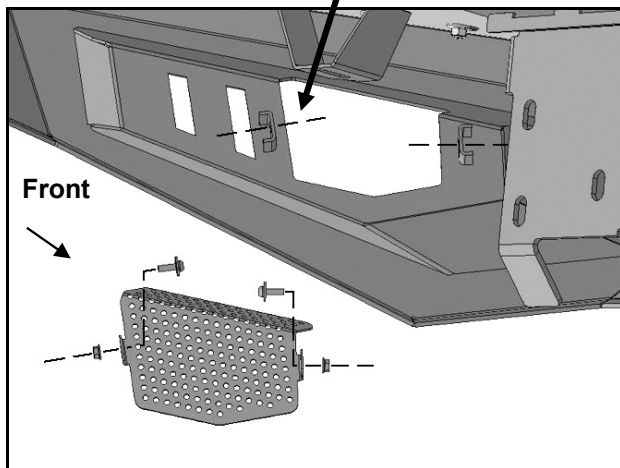

(21) Attach light (not included) or Fill Panel to opening in Bumper

- (4) 8mm Button Head Bolts
- (4) 8mm Lock Washers
- (4) 8mm Flat Washers

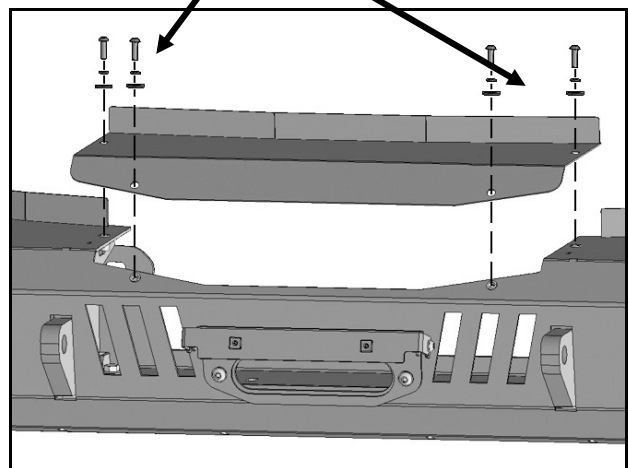

(22) Attach Cover to Bumper (optional)

[View other off-road bumpers made by Torxe on our website.](#)