

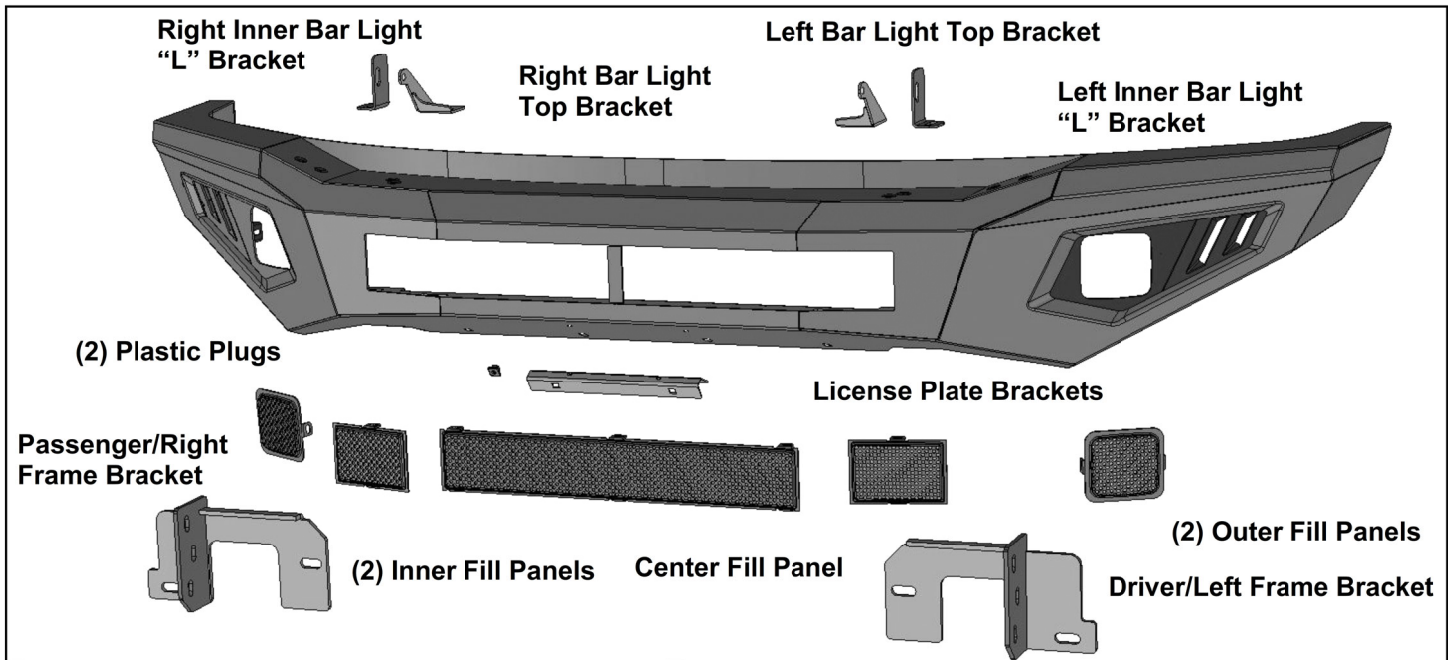

**PARTS LIST:**

**X3B-FORD50-FB**

1	Front Bumper Assembly	6	10mm Lock Washers
2	Small Outer Mesh Plate	6	10mm Hex Nuts
2	Small Inner Mesh Plate	4	8-1.25mm x 25mm Button Head Bolt
1	Long Center Mesh Plate	2	8-1.25mm x 25mm Hex Bolts
1	Driver/left Frame Mounting Bracket	2	8-1.25mm x 16mm Hex Bolts
1	Passenger/right Frame Mounting Bracket	14	8mm x 24mm x 2mm Flat Washers
1	Driver/left Light Bar Bracket (Top LED light)	8	8mm Lock Washers
1	Passenger/right Light Bar Bracket (Top LED light)	6	8mm Hex Nuts
1	Driver/left "L" Light Bar Bracket (Inner LED light)	14	6-1.0mm x 20mm Combine Bolts
1	Passenger/right "L" Light Bar Bracket (inner LED light)	2	6-1.0mm x 20mm Button Head Bolts
1	License Plate Bracket	2	6-1.0mm x 16mm Hex Bolts
2	Plastic Plugs for license plate mount	6	6mm x 18mm x 1.6mm Flat Washers
4	12-1.75mm x 45mm Hex Bolts	2	6mm Lock Washers
8	12mm x 37mm x 3mm Flat Washers	14	6mm Flange Hex Nuts
4	12mm Lock Washers	2	6mm Nylon Lock Nuts
4	12mm Hex Nuts	1	4mm Wrench
6	10-1.5mm x 35mm Hex Bolts	1	5mm Wrench
12	10mm x 27mm OD x 3mm Flat Washers		



**PROCEDURE:**

**REMOVE CONTENTS FROM BOX. VERIFY ALL PARTS ARE PRESENT. READ INSTRUCTIONS CAREFULLY BEFORE STARTING INSTALLATION. ASSISTANCE IS RECOMMENDED TO AVOID POSSIBLE INJURY OR DAMAGE TO THE VEHICLE. LED BAR STYLE CENTER LIGHT MAY INTERFERE WITH AIRFLOW TO INTERCOOLER ON ECOBOOST MODELS.**

1. Remove the hardware attaching the inner splash panels in the fenders to the back of the bumper, **(Figure 1)**. Also remove the license plate and bracket. On models with factory fog lights, unplug both lights and release the wiring harness from the clips attached to the back of the bumper, **(Figure 2)**. Move harness away from bumper.

2. Open the hood and remove the hardware attaching the hood release lever to the steel bracket attached to the back of the bumper, **(Figure 3)**. Also remove the screws attaching the back of the plastic fascia to the hood release bracket and remove the bracket from the bumper, **(Figure 4)**.
3. Place blocks or jack stands under the front bumper to support it during mounting bolt removal. Once the bumper has been safely supported, remove the (2) large hex nuts from the back of each bumper bracket and remove the bumper, **(Figures 5 & 6)**. **WARNING!** Assistance is required to hold the bumper in place during bolt removal to prevent the bumper from falling.
4. Reuse the factory hardware to attach the steel hood release bracket to the mounting tabs on the back of the plastic fascia. Reattach the hood release lever to the steel bracket, **(Figure 7)**. Tighten hardware at this time.
5. Next, select the driver/left Frame Mounting Bracket, **(Figure 8)**. Attach the Bracket to the bumper bracket on the end of the frame with (2) 12mm x 45mm Hex Bolts, (4) 12mm Flat Washers, (2) 12mm Lock Washers and (2) 12mm Hex Nuts, **(Figure 9)**. Leave hardware loose at this time.
6. Repeat **Step 5** to install the passenger/right Frame Mounting Bracket.
7. Carefully unwrap the Bumper assembly. Determine if accessory lights, (not included), or Screen Fill Panels will be installed at this time. **IMPORTANT:** It may be easier to install Center Fill Panels and/or lights before installing Bumper.

**Screen Fill Panel Installation (do not install fill panels if installing lights).**

- a. Select desired Screen Fill Panels. **NOTE:** Outer Panels are square with rounded corners, Inner panels are rectangular with sharp corners, **(Figure 10)**.
- b. Attach Screen Fill Panels as needed with the included 6mm Button Head Combo Bolts and 6mm Flange Nuts, **(Figure 10)**. Fully tighten Fill Panel hardware at this time. Repeat to install all Panels as desired.

**Inner center LED bar style light installation (light not included).**

- a. Select the driver/left "L" Light Bar Bracket. **NOTE:** "L" Brackets are offset to adjust for different widths of LED Bar Lights and can be installed on either side as needed.
- b. Attach the L Bracket to the slot on the back of the Bumper with (1) 8mm x 25mm Hex Bolt, (2) 8mm Flat Washers, (1) 8mm Lock Washer and (1) 8mm Hex Nut, **(Figure 11)**. Repeat this Step to install the remaining "L" Bracket on the other side of the Bumper. **IMPORTANT:** The Bumper features slots designed for 20" and 30" bar style lights. Attach the Brackets to the correct slots in the Bumper. If necessary, hold the light up to the slots to help determine correct slots to use and combination of Brackets.
- c. Attach the light to the "L" Brackets with the hardware included with the light or the supplied (2) 8mm x 16mm Hex Bolts, (2) 8mm Lock Washers and (2) 8mm Flat Washers or (2) 6mm x 16mm Hex Bolts, (2) 6mm Lock Washers and (2) 6mm Flat Washers, **(Figures 11 & 12)**. Do not fully tighten hardware at this time.

**Top mounted 30" bar style LED light (not included).**

- a. Remove the (2) rubber plugs from the driver/left side mounting holes, **(Figure 13)**.
- b. Select the driver/left Light Bracket. Attach the Bracket to the top of the Bumper with (2) 8mm x 25mm Button Head Bolts, (4) 8mm Flat Washers, (2) 8mm Lock Washers and (2) 8mm Hex Nuts, **(Figure 13)**. Do not tighten hardware at this time.
- c. Repeat previous Steps to attach the passenger/right Bracket.
- d. Select the 30" light, (not included). Attach light to Top Brackets with the hardware included with the light. Adjust the width of the Brackets to the light and fully tighten bracket hardware.  
**IMPORTANT:** Top Light Brackets are designed to install 30" bar style LED lights with outside length dimensions of 31.653" (804mm) to 32.44" (824mm) only, **(Figure 14)**. Fully tighten top light hardware once adjusted.

**Outer LED cube style light installation (light not included).**

- a. Attach lights to mounting tabs on back of each end of the Bumper, **(Figure 16)**.
8. With assistance, position the Bumper Assembly up to the mounting flanges on the Frame Brackets, **(Figure 15)**. Temporarily support the weight of the Bumper. **WARNING:** To avoid possible injury or damage to the vehicle, do not proceed until the bumper is fully and safely supported. Attach the Bumper to the Frame Brackets with (6) 10mm x 35mm Hex Bolts, (12) 10mm Flat Washers, (6) 10mm Lock Washers and (6) 10mm Hex Nuts, **(Figures 15 & 16)**. Do not fully tighten at this time.

9. Level and adjust the bumper and fully tighten all hardware.
10. If front license plate is required, attach the License Plate Bracket to the holes in the bumper with the included (2) 6mm x 20mm Button Head Screws, (4) 6mm Flat Washers and (2) 6mm Nylon Lock Nuts. Insert (2) Plastic Plugs into the square holes in the Bracket. Reuse the factory screws to attach the license plate to the plastic plugs, **(Figure 17)**.
11. Do periodic inspections to the installation to make sure that all hardware is secure and tight.

**To protect your investment,** Do not use any type of polish or wax that may contain abrasives that could damage the finish. Mild soap may be used to clean the Bumper assembly.

### Driver Side Installation Pictured

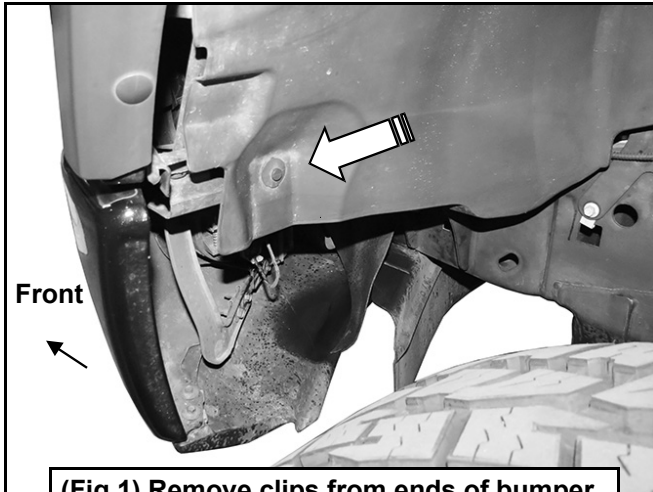

**(Fig 1) Remove clips from ends of bumper**



**(Fig 2) Unplug factory fog light if equipped. Release clips and move wire harness away from bumper**

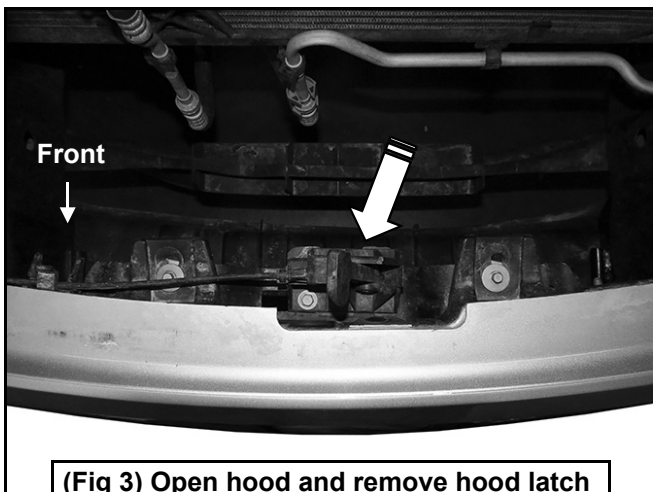

**(Fig 3) Open hood and remove hood latch (arrow) from bracket on back of bumper**

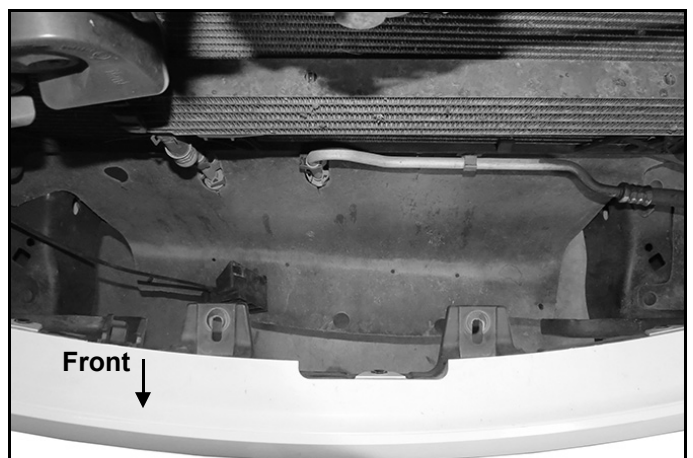

**(Fig 4) Remove hood latch bracket from back of bumper**

Driver Side Installation Pictured

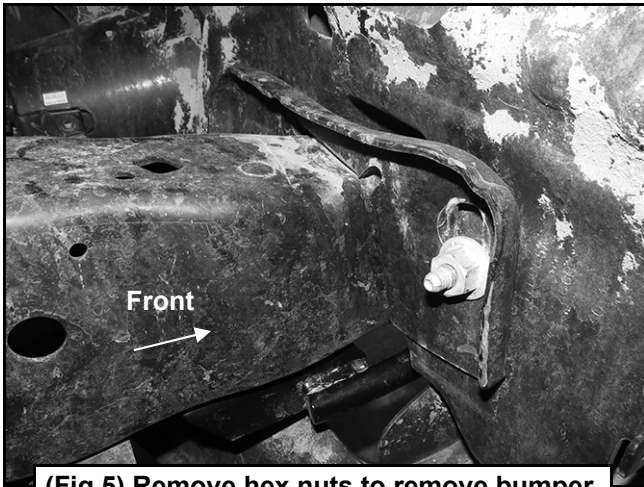

(Fig 5) Remove hex nuts to remove bumper

**WARNING!** Do not remove bumper bolts unless the bumper is properly supported on blocks or stands or the bumper may fall.



(Fig 6) Remove bumper assembly

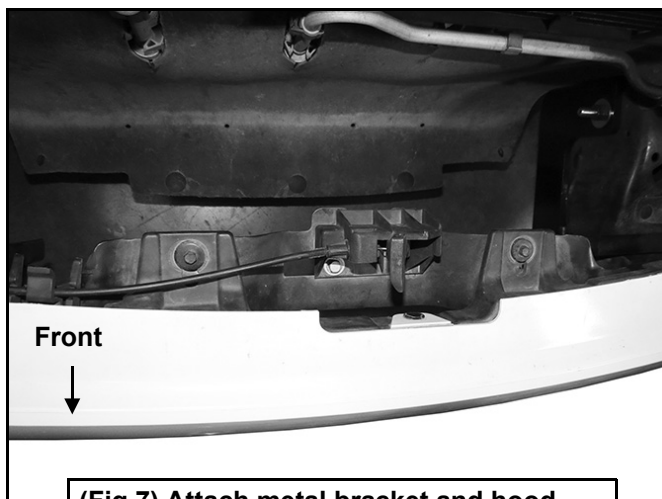

(Fig 7) Attach metal bracket and hood latch to back of plastic fascia body panel

- (2) 12mm x 45mm Hex Bolts
- (4) 12mm Flat Washers
- (2) 12mm Lock Washers
- (2) 12mm Hex Nuts

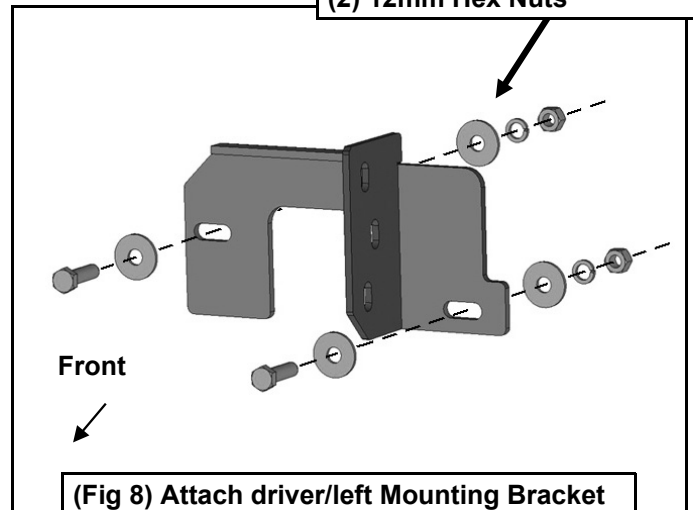

(Fig 8) Attach driver/left Mounting Bracket to the bumper flange on the end of frame

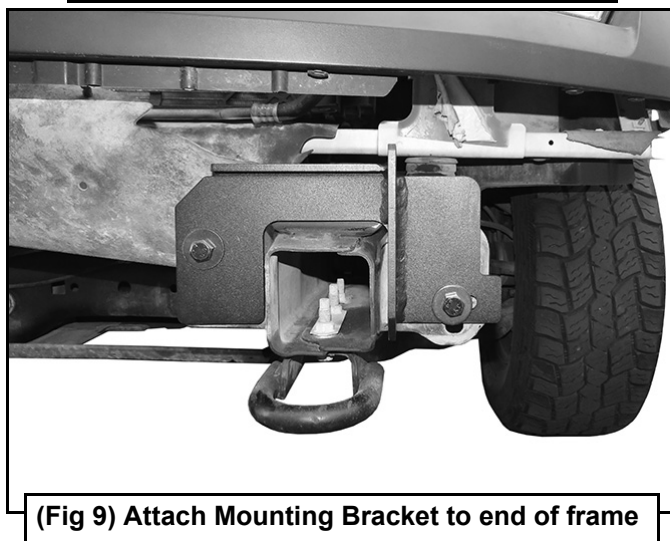

(Fig 9) Attach Mounting Bracket to end of frame

**Driver Side Installation Pictured**

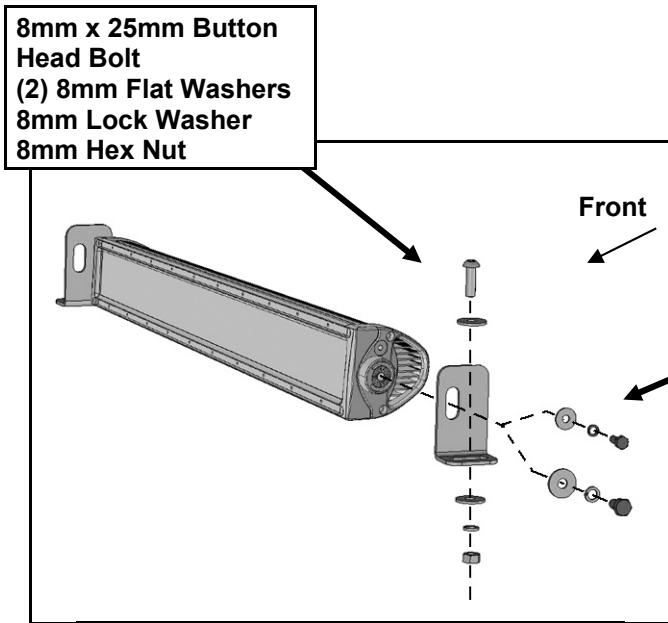
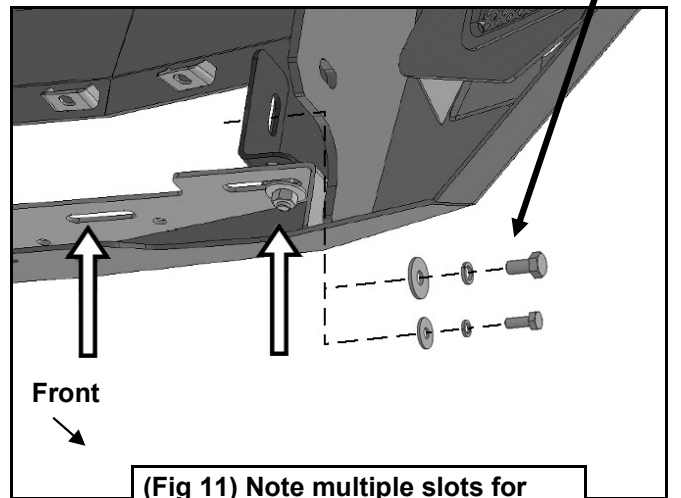
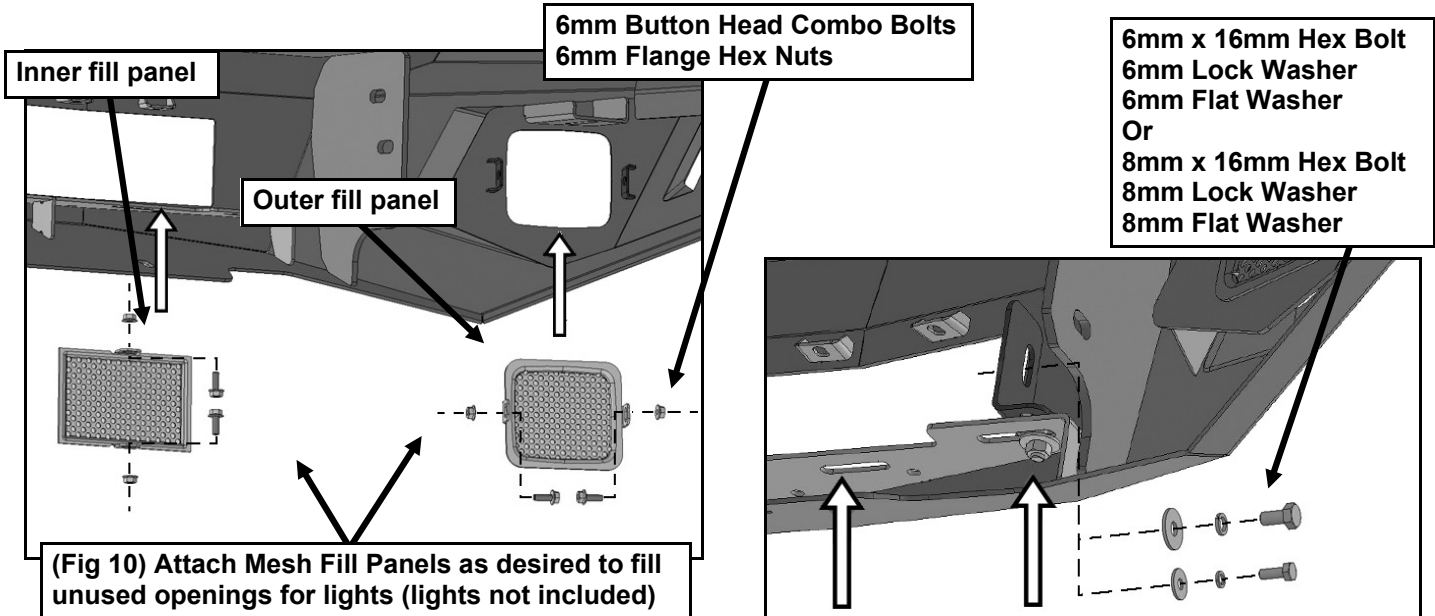

**(Fig 12) Attach LED bar style light to "L" Brackets (light available separately)**

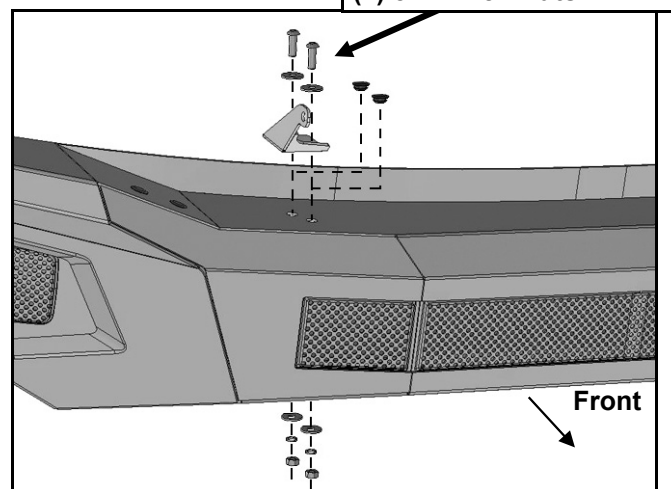
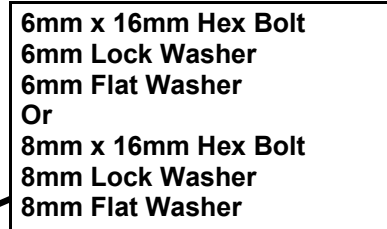

**(Fig 13) Remove rubber plugs to attach Top Light Bracket to Bumper**

Driver Side Installation Pictured

Top Light bracket mounting location is designed for light assembly 31.65" (804mm) to 32.44" (824mm)

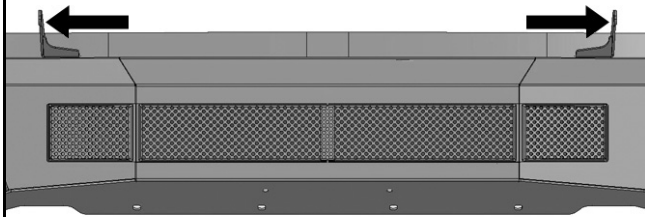

(Fig 14) Measure width of LED light (light only) before installation of Top Light Brackets

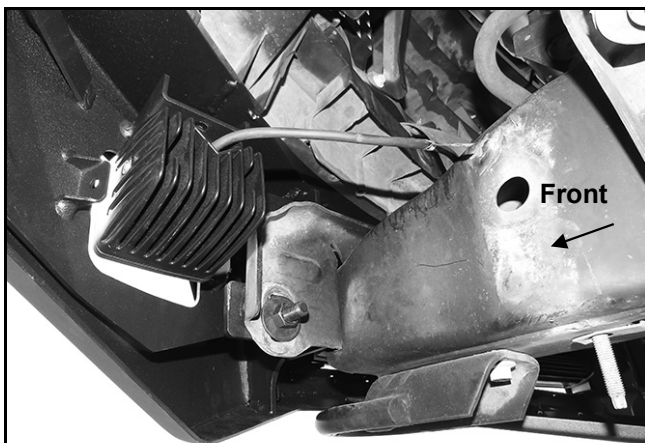

(Fig 16) Driver/left side of Bumper fully installed (light available separately)



**WARNING!** Do not crawl under bumper unless the bumper is properly supported on blocks or stands or the bumper may fall.

- (3) 10mm x 35mm Hex Bolts
- (6) 10mm Flat Washers
- (3) 10mm Lock Washers
- (3) 10mm Hex Nuts

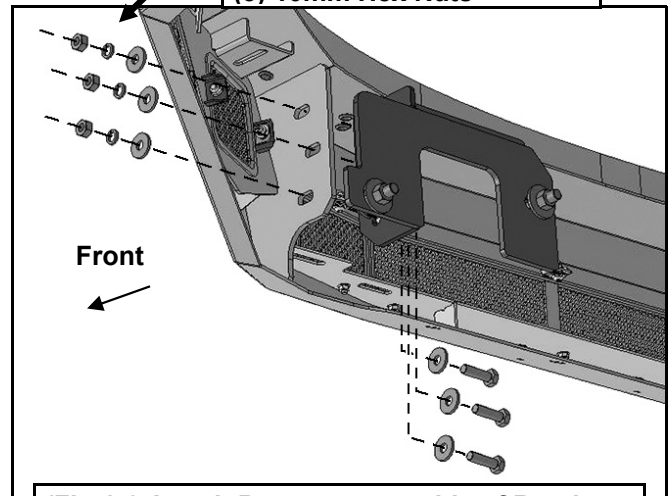

(Fig 15) Attach Bumper to outside of Brackets

- (2) 6mm x 20mm Button Head Screws
- (4) 6mm Flat Washers
- (2) 6mm Nylon Lock Nuts

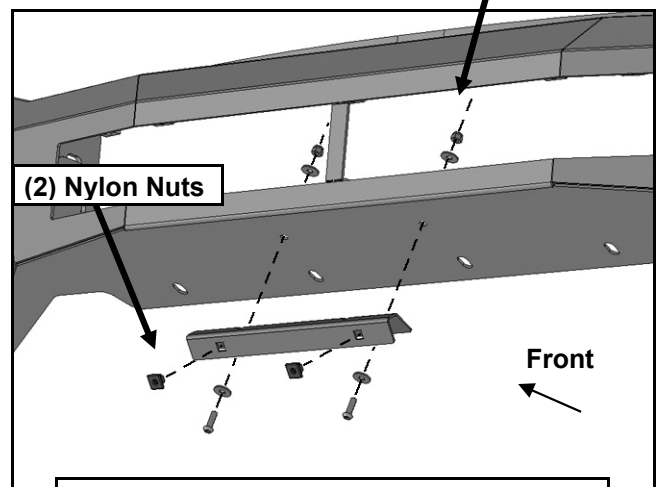

(Fig 17) Insert Plastic Plugs into Bumper. Attach License Plate to Plastic Plugs