

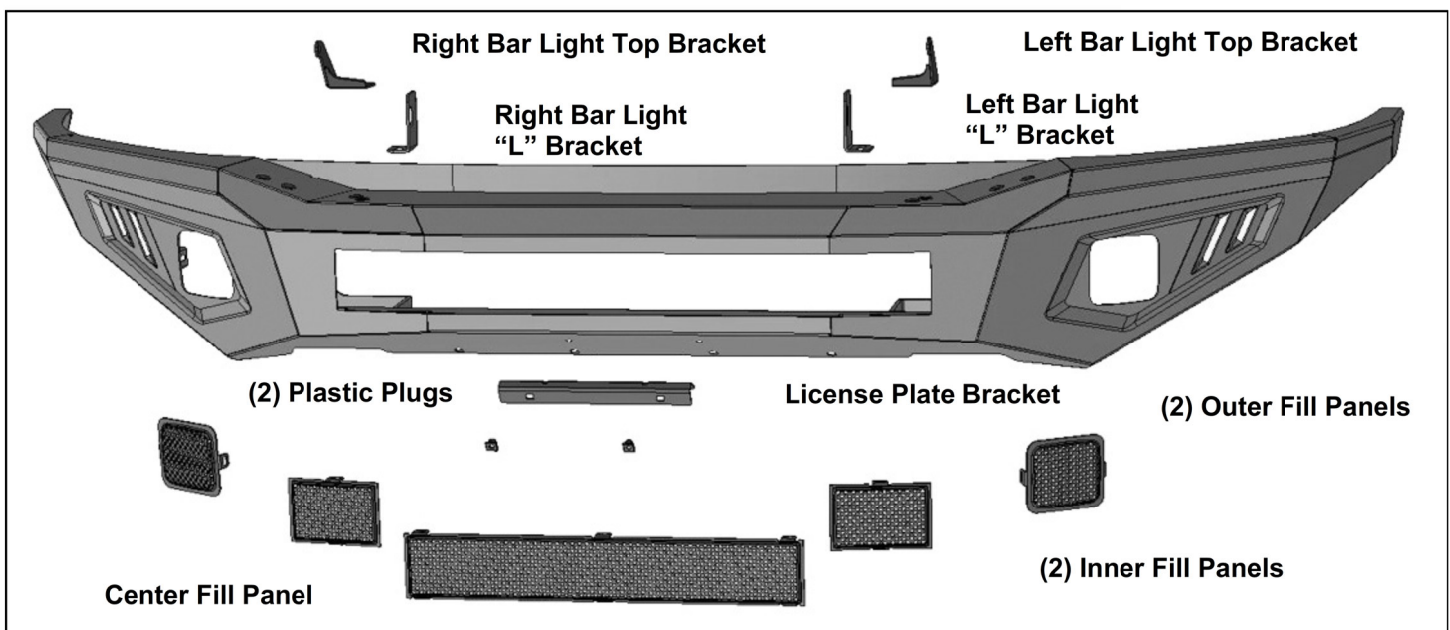

**PARTS LIST:**

1	LD2 Front Bumper Assembly	4	8-1.25mm x 25mm Button Head Bolts
1	Long Center Mesh Plate	2	8-1.25mm x 25mm Hex Bolts
2	Short Inner Mesh Plates	2	8-1.25mm x 16mm Hex Bolts
2	Small Outer Mesh Plates	14	8mm x 24mm Flat Washers
1	Driver/Left Bumper Top Light Mount	8	8mm Lock Washers
1	Passenger/Right Bumper Top Light Mount	6	8mm Hex Nuts
1	Driver/left "L" Bracket (center LED light)	14	6-1.0mm x 20mm Combo Hex Bolts
1	Passenger/right "L" Bracket (center LED light)	2	6mm x 20mm Button Head Bolts
1	License Plate Bracket	2	6mm x 16mm Hex Bolts
2	Plastic Plugs for license plate mount	6	6mm x 18mm x 1.6mm Flat Washers
6	12-1.75mm x 40mm Hex Bolts	2	6mm Lock Washers
12	12mm x 32mm x 3mm Flat Washers	2	6mm Nylon Lock Nuts
6	12mm Lock Washers	14	6mm Flange Nuts
6	12mm Hex Nuts	1	5mm Wrench
10	Nylon Wire Ties	1	4mm Wrench



**PROCEDURE:**

**REMOVE CONTENTS FROM BOX. VERIFY ALL PARTS ARE PRESENT. READ INSTRUCTIONS CAREFULLY BEFORE STARTING INSTALLATION. BUMPER IS HEAVY, ASSISTANCE IS HIGHLY RECOMMENDED TO AVOID POSSIBLE INJURY OR DAMAGE TO THE VEHICLE.**

1. Remove the license plate and bracket. Remove the driver/left lower plastic fender liner, **(Figure 1)**. On models with factory fog lights, unplug all wiring harnesses leading to the front bumper, **(Figure 1)**. Move harnesses away from bumper. Move to the passenger/right side and repeat this **Step**.
2. Place blocks or jack stands under the bumper to support it during mounting bolt removal. Once the bumper has been safely supported, remove the (3) hex nuts attaching each bumper bracket to the end of the frame, **(Figure 2)**. On models with tow hooks, (2) of the hex nuts attach the "L" bracket for the tow hooks to the back of the bumper bracket. Remove the (2) hex nuts but it is not necessary to remove the "L" brackets and tow hooks, **(Figure 2)**. **WARNING!** Assistance is required to hold bumper in place during hardware removal to prevent the bumper from falling.

3. Slide the bumper assembly off of the end of the frame and tow hooks if equipped, **(Figure 3)**.
4. Carefully unwrap the Bumper assembly. Determine if accessory lights, (not included), or Screen Fill Panels will be installed at this time. **NOTE:** It may be easier to install Center Fill Panels and/or lights before installing Bumper.

**Screen Fill Panel Installation, (do not install fill panels if installing lights).**

- a. Select desired Screen Fill Panels. **NOTE:** Outer Panels are square with rounded corners, Inner panels are rectangular with sharp corners, **(Figure 4)**.
- b. Attach Screen Fill Panels as needed with the included 6mm Button Head Combo Bolts and 6mm Flange Nuts, **(Figure 4)**. Fully tighten Fill Panel hardware at this time. Repeat to install all Panels as desired.

**Inner center LED bar style light installation, (light not included).**

- a. Select the passenger/right "L" Light Bar Bracket, **(Figure 5)**. **NOTE:** "L" Brackets are offset to adjust for different widths of LED Bar Lights and can be installed on either side as needed.
- b. Attach the "L" Bracket to the slot on the back of the Bumper with (1) 8mm x 25mm Hex Bolt, (2) 8mm Flat Washers, (1) 8mm Lock Washer and (1) 8mm Hex Nut, **(Figure 5)**. Repeat this Step to install the remaining "L" Bracket on the other side of the Bumper. **IMPORTANT:** The Bumper features slots designed for 20" and 30" bar style lights. Attach the Brackets to the correct slots in the Bumper. If necessary, hold the light up to the slots to help determine correct slots to use and combination of Brackets.
- c. Attach the light to the "L" Brackets with the hardware included with the light or the supplied (2) 8mm x 16mm Hex Bolts, (2) 8mm Lock Washers and (2) 8mm Flat Washers or (2) 6mm x 16mm Hex Bolts, (2) 6mm Lock Washers and (2) 6mm Flat Washers, **(Figures 5 & 6)**. Do not fully tighten hardware at this time.

**Top mounted 30" bar style LED light (not included).**

- a. Remove the (2) rubber plugs from the passenger/right side mounting holes in the top of the Bumper, **(Figure 7)**.
- b. Select the passenger/right Light Bracket. Attach the Bracket to the Bumper with (2) 8mm x 25mm Button Head Bolts, (4) 8mm Flat Washers, (2) 8mm Lock Washers and (2) 8mm Hex Nuts, **(Figure 7)**. Do not tighten hardware at this time.
- c. Repeat previous Steps to attach the driver/left Light Bracket.
- d. Select the 30" light, (not included). Attach light to Top Brackets with the hardware included with the light. Adjust the width of the Brackets to the light and fully tighten bracket hardware.  
**IMPORTANT:** Top Light Brackets are designed to install 30" bar style LED lights with outside length dimensions of 31.653" (804mm) to 32.44" (824mm) only, **(Figure 8)**. Fully tighten top light hardware once adjusted.

**Outer LED cube style light installation (light not included).**

- a. Attach lights to mounting tabs on back of each end of the Bumper, **(Figure 4)**.
5. If front license plate is required, attach the License Plate Bracket to the holes in the bumper with the included (2) 6mm x 20mm Button Head Bolts, (4) 6mm x 18mm Large Flat Washers and (2) 6mm Nylon Lock Nuts, **(Figure 9)**. Insert (2) Plastic Plugs into the square holes in the Bracket. Reuse the factory screws to attach the license plate to the plastic plugs.
6. With assistance, position the LD2 Bumper Assembly up to the end of the frame. Temporarily support the weight of the Bumper. **WARNING:** To avoid possible injury or damage to the vehicle, do not proceed until the Bumper is fully and safely supported.
7. Attach the driver/left side of the Bumper to the frame with (3) 12mm x 40mm Hex Bolts, (6) 12mm Flat Washers, (3) 12mm Lock Washers and (3) 12mm Hex Nuts, **(Figures 10 & 11)**. Do not fully tighten at this time. Repeat this **Step** to attach the passenger/right side of the Bumper to the frame.
8. Level and adjust the bumper and fully tighten all hardware.
9. Do periodic inspections to the installation to make sure that all hardware is secure and tight.

**To protect your investment,** Do not use any type of polish or wax that may contain abrasives that could damage the finish. Mild soap may be used to clean the Bumper assembly.



(Fig 1) Remove lower fender liner. Unplug wiring harness leading to front bumper

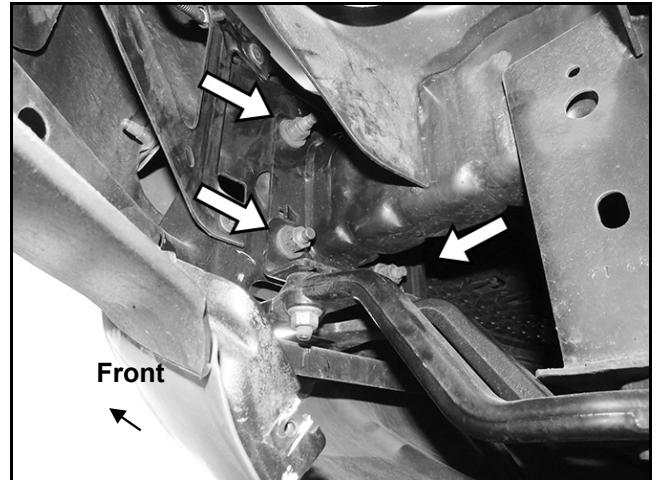

(Fig 2) Unplug lights and sensors if equipped. Unplug harness to bumper and move harness. Remove (3) factory hex nuts from each side

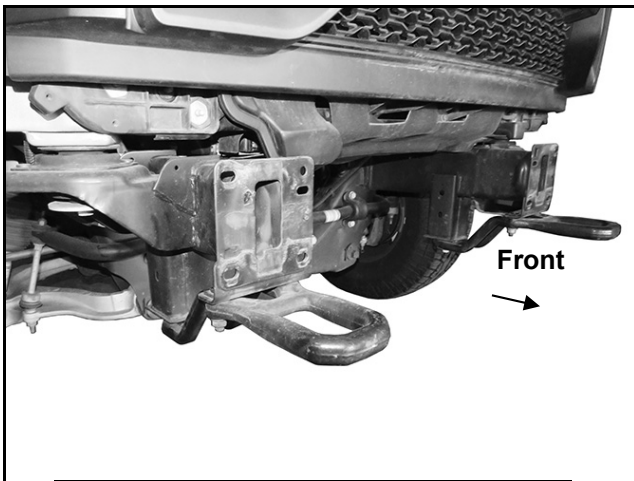

(Fig 3) Temporarily remove tow hooks

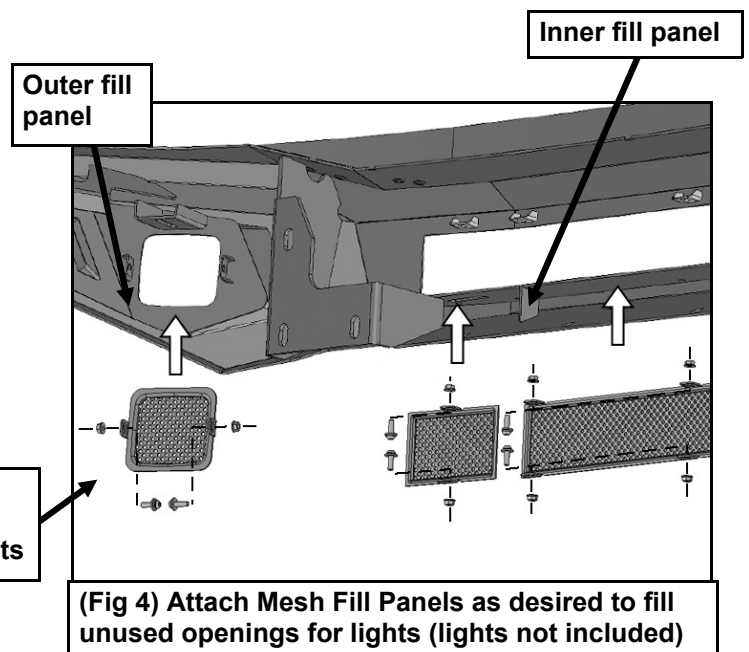

(Fig 4) Attach Mesh Fill Panels as desired to fill unused openings for lights (lights not included)

8mm x 25mm Hex Bolt  
(2) 8mm Flat Washers  
8mm Lock Washer  
8mm Hex Nut

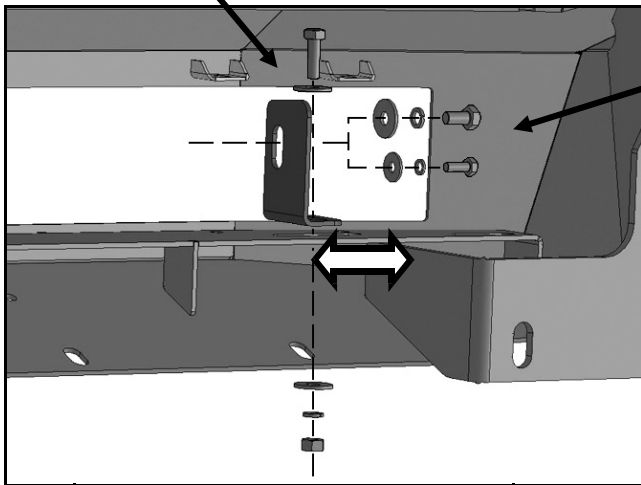

(Fig 5) Note multiple slots for different widths of lights (arrow)

6mm x 16mm Hex Bolt  
6mm Lock Washer  
6mm Flat Washer  
Or  
8mm x 16mm Hex Bolt  
8mm Lock Washer  
8mm Flat Washer

6mm x 16mm Hex Bolt  
6mm Lock Washer  
6mm Flat Washer  
Or  
8mm x 16mm Hex Bolt  
8mm Lock Washer  
8mm Flat Washer

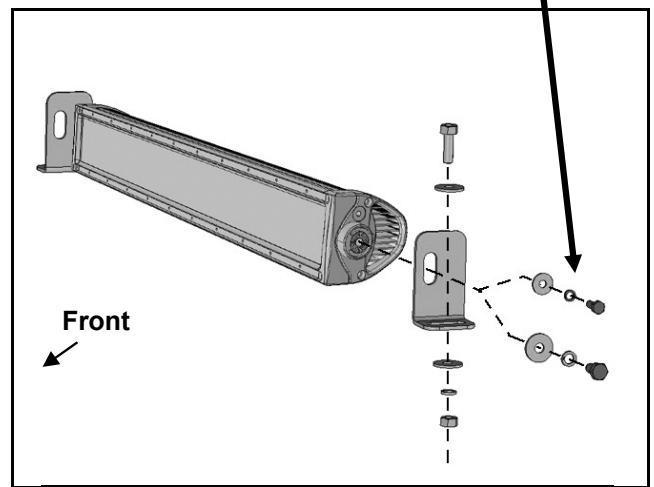

(Fig 6) Bracket illustration is a suggestion only. Brackets are offset to allow adjustment for all widths of lights

(2) 8mm x 25mm Button Head Bolts  
(4) 8mm Flat Washers  
(2) 8mm Lock Washers  
(2) 8mm Hex Nuts

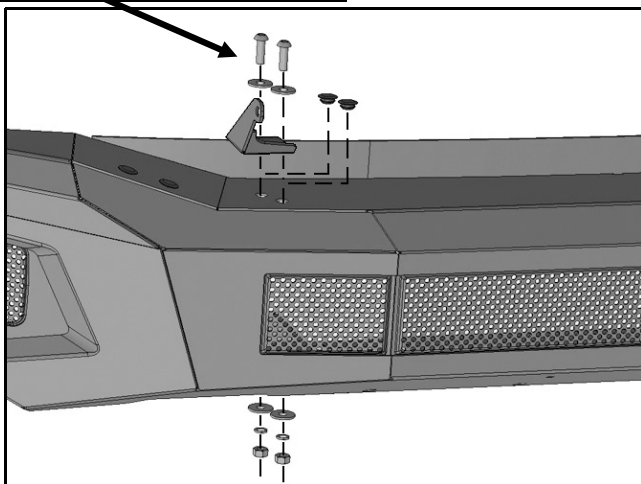

(Fig 7) Remove rubber plugs to attach Top Light Bracket to Bumper

Top Light bracket mounting location is designed for light assembly 31.65" (804mm) to 32.44" (824mm)

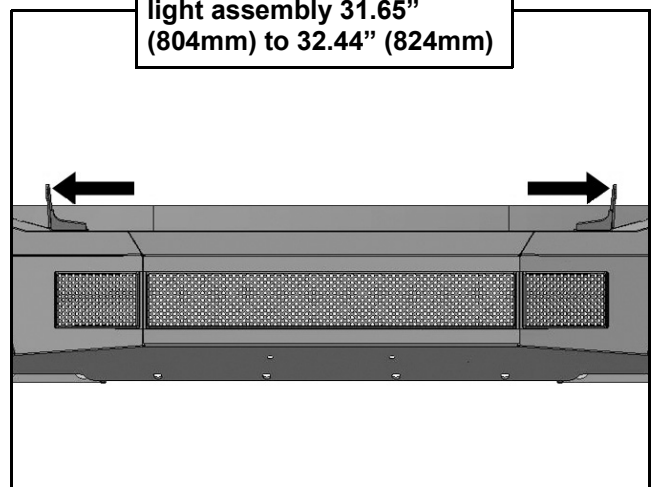

(Fig 8) Measure width of LED light (light only) before installation of Top Light Brackets

- (2) 6mm x 20mm Button Head Bolts
- (4) 6mm Flat Washers
- (2) 6mm Nylon Lock Nuts

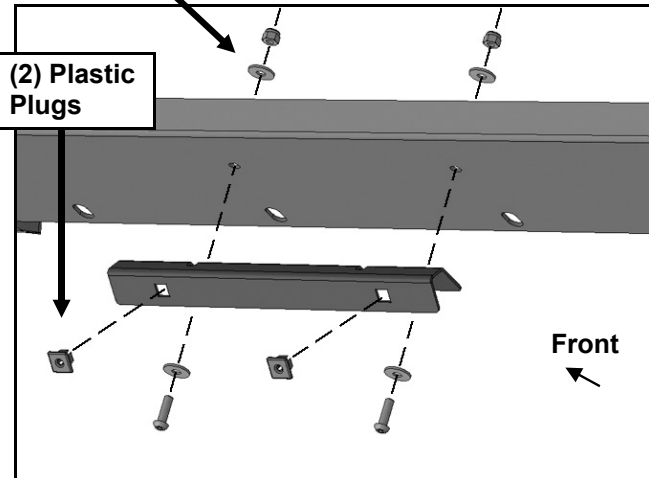

(Fig 9) Attach License Plate Bracket to Bumper

**WARNING!** Do not crawl under bumper unless the bumper is properly supported on blocks or stands or it may fall.

- (3) 12mm x 40mm Hex Bolts
- (6) 12mm Flat Washers
- (3) 12mm Lock Washers
- (3) 12mm Hex Nuts

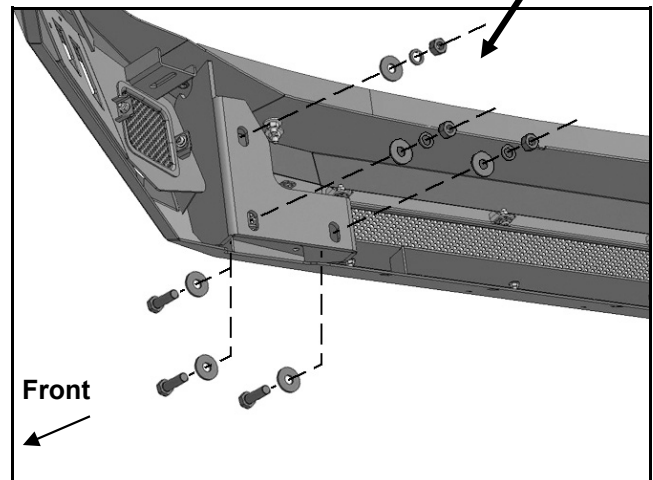

(Fig 10) Attach Bumper assembly to end of frame

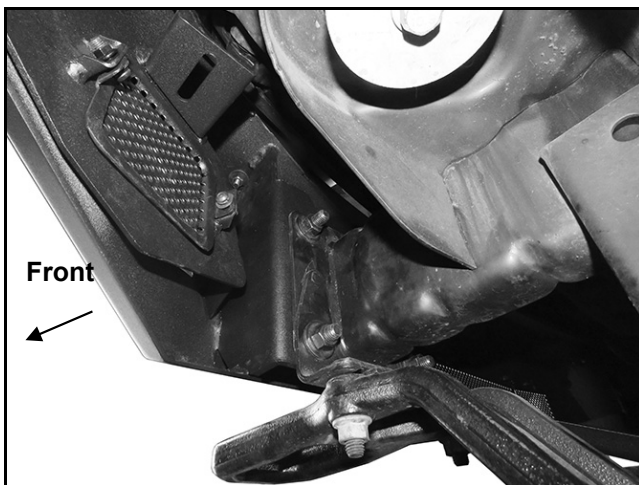

(Fig 11) Driver/left side complete installation



Discover other off-road bumpers on our website.