

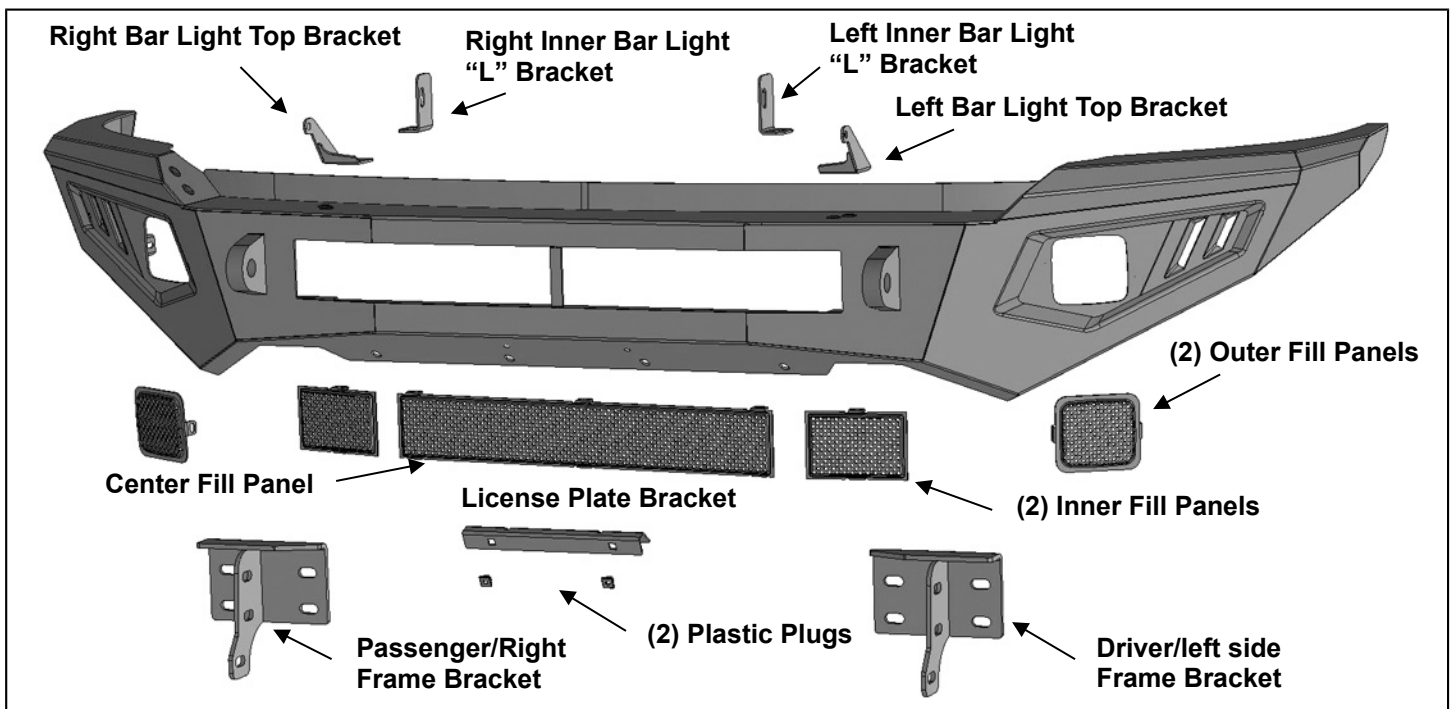

PARTS LIST: X3-DRAM45-FB

1	LD2 Front Bumper	6	12mm Nylon Lock Nuts
1	Driver/left side Frame Mounting Bracket	4	8-1.25mm x 25mm Button Head Bolts
1	Passenger/right side Frame Mounting Bracket	2	8-1.25mm x 25mm Hex Bolts
1	Long Center Mesh Plate	2	8-1.25mm x 16mm Hex Bolts
2	Short Inner Mesh Plates	14	8mm x 24mm x 2mm Flat Washers
2	Small Outer Mesh Plates	8	8mm Lock Washers
1	License Plate Bracket	6	8-1.25mm Hex Nuts
2	License Plastic Plugs	14	6mm x 20mm Combo Bolts
1	Driver/Left Bumper Top Light Mount	2	6-1.0mm x 20mm Button Head Bolts
1	Passenger/Right Bumper Top Light Mount	2	6-1.0mm x 16mm Hex Bolts
1	Driver/left "L" Bracket (center LED light)	6	6mm x 18mm x 1.6mm Flat Washers
1	Passenger/right "L" Bracket (center LED light)	2	6mm Lock Washers
8	12-1.75mm x 50mm Hex Bolts	14	6mm Flange Nuts
6	12-1.75mm x 40mm Hex Bolts	2	6mm Nylon Lock Nuts
12	12mm x 37mm x 3mm Flat Washers	1	5mm Allen Wrench
16	12mm x 32mm x 3mm Flat Washers	1	4mm Allen Wrench
8	12mm Lock Washers	10	200mm Nylon Wire Ties
8	12-1.75mm Hex Nuts		



PROCEDURE:

REMOVE CONTENTS FROM BOX. VERIFY ALL PARTS ARE PRESENT. READ INSTRUCTIONS CAREFULLY BEFORE STARTING INSTALLATION. ASSISTANCE IS HIGHLY RECOMMENDED TO AVOID POSSIBLE INJURY OR DAMAGE TO THE VEHICLE. CUTTING MAY BE REQUIRED.

1. Remove the license plate and bracket. On models with factory fog lights and/or sensors, unplug wiring harness leading to the front bumper, **(Figure 1)**. Release the harness from the clips attached to the back of the bumper and move harness away from bumper.

2. Next, open hood and remove the plastic cover between the top of the grille and the top of the radiator. Carefully remove the grill assembly, **(Figures 2 & 3)**.
3. Place blocks or jack stands under the front bumper to support it during mounting bolt removal. Once the bumper has been safely supported, remove the hex nuts attaching the bottom of the bumper to the mounting brackets on the end of the frame, **(Figure 4)**. Next, from above, remove the upper hex nuts and Slide the bumper off of the tow hooks, **(Figure 4)**. **WARNING!** Assistance is required to hold the bumper in place during hardware removal to prevent the bumper from falling.
4. Next, remove the tow hooks from the end of the frame, **(Figures 5 & 6)**.
5. Select the driver/left side Frame Mounting Bracket, **(Figure 7)**. Attach the Bracket to the end of the frame with (4) 12mm x 50mm Hex Bolts, (8) 12mm x 32mm Flat Washers, (4) 12mm Lock Washers and (4) 12mm Hex Nuts, **(Figure 8)**. Leave hardware loose. Repeat this **Step** to install the passenger/right Frame Bracket.
6. Carefully unwrap the Bumper assembly. Determine if accessory lights, (not included), or Screen Fill Panels will be installed at this time. **IMPORTANT:** It may be easier to install Center Fill Panels and/or lights before installing Bumper.

Screen Fill Panel Installation (do not install fill panels if installing lights).

- a. Select desired Screen Fill Panels. **NOTE:** Outer Panels are square with rounded corners, Inner panels are rectangular with sharp corners, **(Figure 9)**.
- b. Attach Screen Fill Panels as needed with the included 6mm Button Head Combo Bolts and 6mm Flange Nuts, **(Figure 9)**. Fully tighten Fill Panel hardware at this time. Repeat to install all Panels as desired.

Inner center LED bar style light installation (light not included).

- a. Select the driver/left "L" Light Bar Bracket, **(Figure 10)**. **NOTE:** "L" Brackets are offset to adjust for different widths of LED Bar Lights and can be installed on either side as needed.
- b. Attach the L Bracket to the slot on the back of the Bumper with (1) 8mm x 25mm Hex Bolt, (2) 8mm Flat Washers, (1) 8mm Lock Washer and (1) 8mm Hex Nut, **(Figures 10 & 11)**. Repeat this Step to install the remaining "L" Bracket on the other side of the Bumper. **IMPORTANT:** The Bumper features slots designed for 20" and 30" bar style lights. Attach the Brackets to the correct slots in the Bumper. If necessary, hold the light up to the slots to help determine correct slots to use and combination of Brackets.
- c. Attach the light to the "L" Brackets with the hardware included with the light or the supplied (2) 8mm x 16mm Hex Bolts, (2) 8mm Lock Washers and (2) 8mm Flat Washers or (2) 6mm x 16mm Hex Bolts, (2) 6mm Lock Washers and (2) 6mm Flat Washers, **(Figures 10 & 11)**. Do not fully tighten hardware at this time.

Top mounted 30" bar style LED light (not included).

- a. Remove the (2) rubber plugs from the driver/left side mounting holes, **(Figure 12)**.
- b. Select the driver/left Light Bracket. Attach the Bracket to the top of the Bumper with (2) 8mm x 25mm Button Head Bolts, (4) 8mm Flat Washers, (2) 8mm Lock Washers and (2) 8mm Hex Nuts, **(Figure 12)**. Do not tighten hardware at this time.
- c. Repeat previous Steps to attach the passenger/right Bracket.
- d. Select the 30" light, (not included). Attach light to Top Brackets with the hardware included with the light. Adjust the width of the Brackets to the light and fully tighten bracket hardware.
IMPORTANT: Top Light Brackets are designed to install 30" bar style LED lights with outside length dimensions of 31.653" (804mm) to 32.44" (824mm) only, **(Figure 13)**. Fully tighten top light hardware once adjusted.

Outer LED cube style light installation (light not included).

- a. Attach lights to mounting tabs on back of each end of the Bumper, **(Figure 9)**.
7. With assistance, position the LD2 Bumper Assembly up to the inside of the Frame Brackets. Temporarily support the weight of the Bumper. **WARNING:** To avoid possible injury or damage to the vehicle, do not proceed until the Bumper is fully and safely supported.
8. Attach the Bumper to the Frame Brackets with the included (6) 12mm x 40mm Hex Bolts, (12) 12mm x 37mm Flat Washers and (6) 12mm Nylon Lock Nuts, **(Figures 14 & 15)**. Do not fully tighten hardware.
9. Level and adjust the bumper and fully tighten all hardware. Reinstall grille and cover removed in Step 2.

**LD2 FRONT BUMPER
2010-18 RAM 25-3500**

10. If front license plate is required, attach the License Plate Bracket to the holes in the bumper with the included (2) 6mm x 20mm Button Head Bolts, (4) 6mm Flat Washers and (2) 6mm Nylon Lock Nuts, **(Figure 16)**. Insert (2) Plastic Plugs into the square holes in the Bracket. Reuse the factory screws to attach the license plate to the plastic plugs.
11. Do periodic inspections to the installation to make sure that all hardware is secure and tight.

To protect your investment, Do not use any type of polish or wax that may contain abrasives that could damage the finish. Mild soap may be used to clean the Bumper assembly.

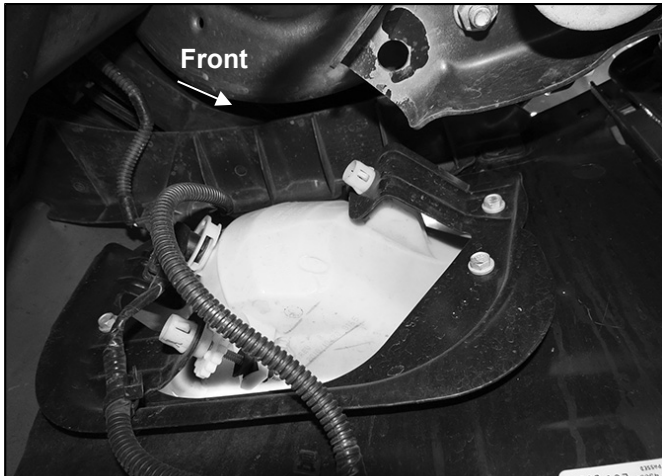

(Fig 1) Unplug harness to bumper and move harness

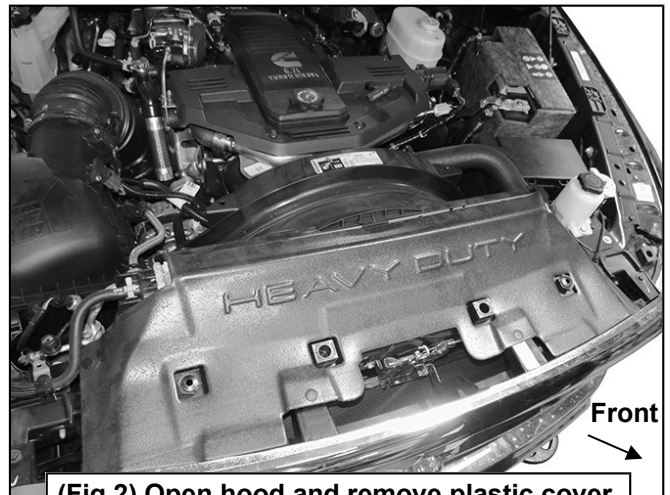

(Fig 2) Open hood and remove plastic cover

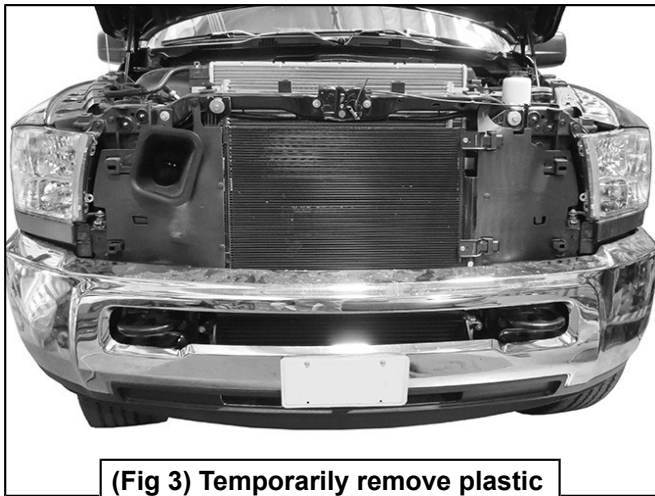

(Fig 3) Temporarily remove plastic grille to access top bumper bolts

WARNING! Do not remove bumper bolts unless the bumper is properly supported on blocks or stands or the bumper may fall.

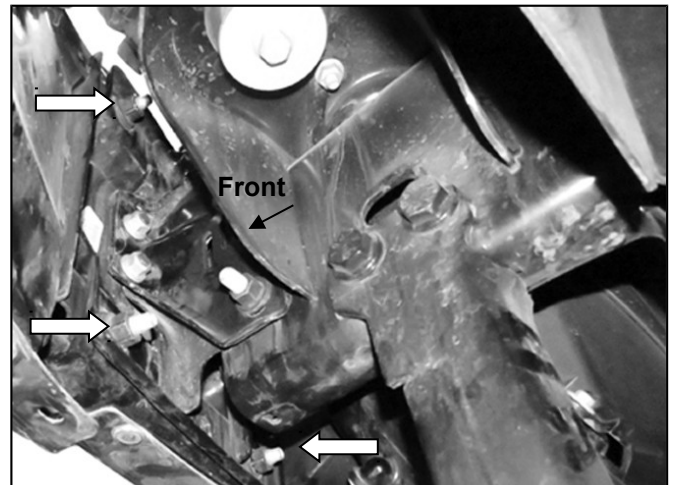

(Fig 4) Remove hex nuts from bumper bolts (arrows). Bumper bracket pictured from below/behind bumper

Driver Side Installation Pictured

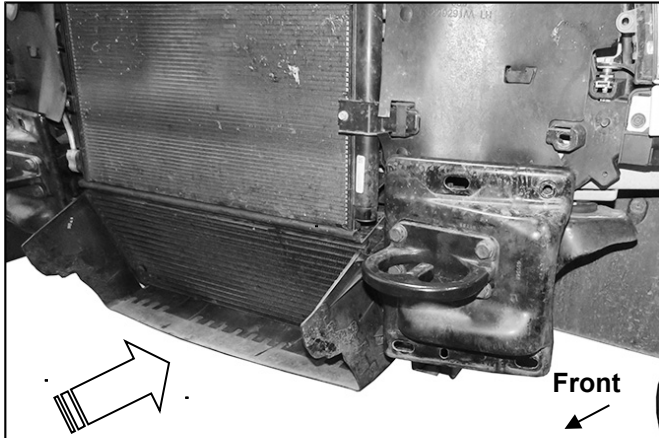

(Fig 5) Remove tow hooks. On models equipped with diesel, remove plastic shroud (arrow)

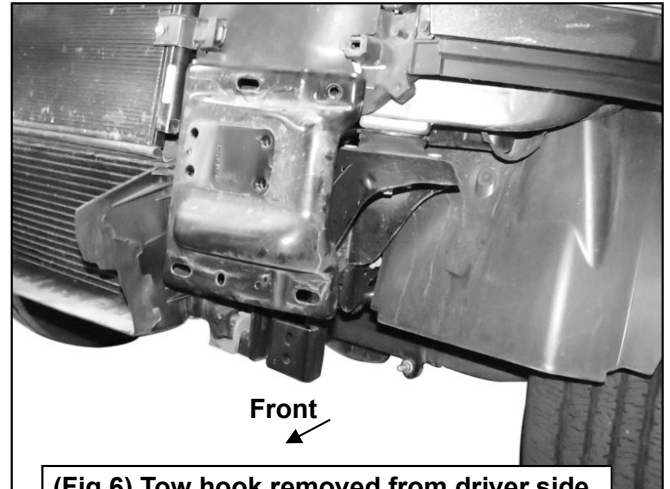

(Fig 6) Tow hook removed from driver side

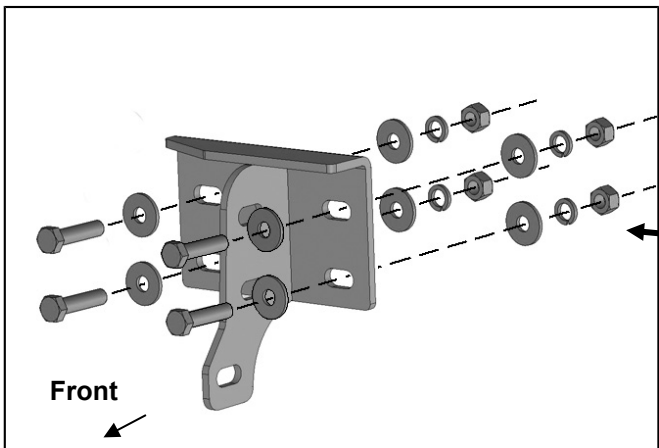

(Fig 7) Attach driver/left Frame Bracket to frame

- (4) 12mm x 50mm Hex Bolts
- (8) 12mm x 32mm STD Flat Washers
- (4) 12mm Lock Washers
- (4) 12mm Hex Nuts

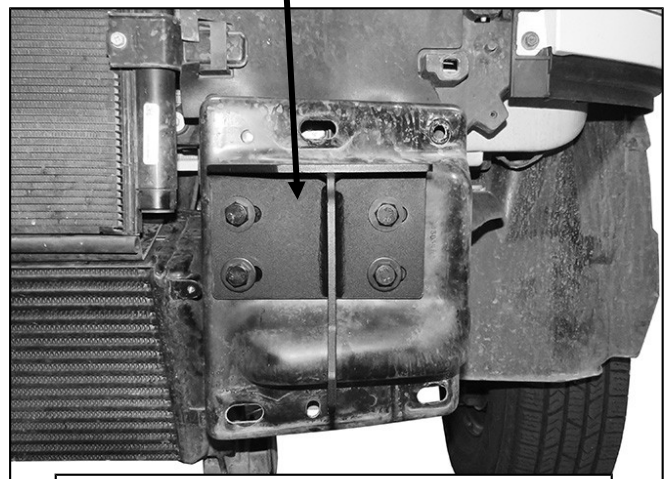

(Fig 8) Driver/left Frame Bracket installed

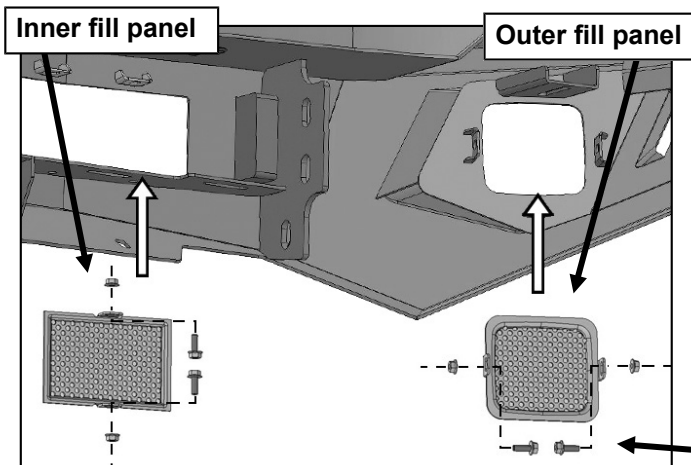

(Fig 9) Attach Mesh Fill Panels as desired to fill unused openings for lights (lights not included)

- 6mm Button Head Combo Bolts
- 6mm Flange Hex Nuts

Driver Side Installation Pictured

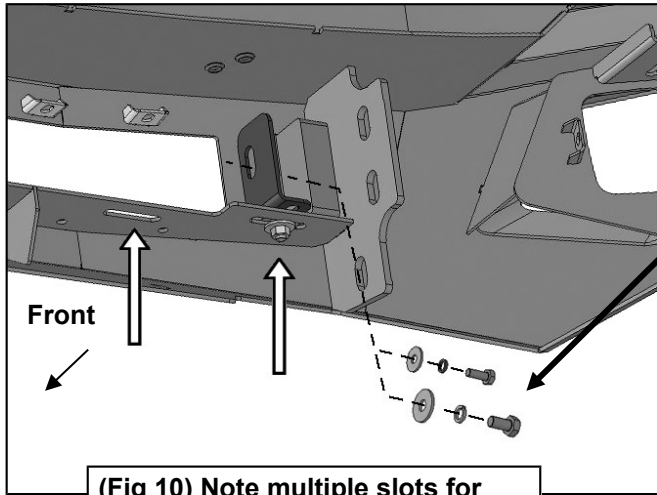

(Fig 10) Note multiple slots for different widths of lights (arrows)

- 6mm x 16mm Hex Bolt
- 6mm Lock Washer
- 6mm Flat Washer
- Or
- 8mm x 16mm Hex Bolt
- 8mm Lock Washer
- 8mm Flat Washer

- 8mm x 25mm Hex Bolt
- (2) 8mm Flat Washers
- 8mm Lock Washer
- 8mm Hex Nut

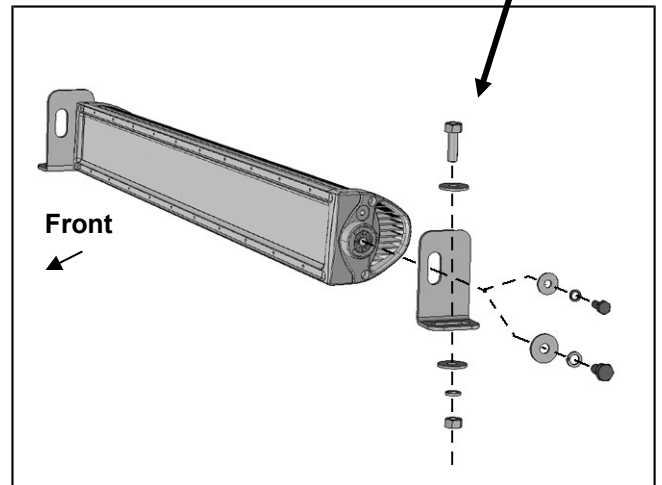

(Fig 11) Bracket illustration is a suggestion only. Brackets are offset to allow adjustment for all widths of lights

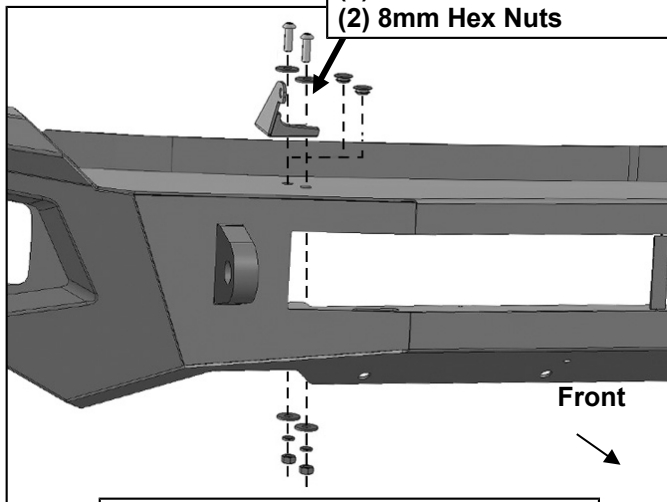

- (2) 8mm x 25mm Button Head Bolts
- (4) 8mm Flat Washers
- (2) 8mm Lock Washers
- (2) 8mm Hex Nuts

(Fig 12) Remove rubber plugs to attach Top Light Bracket to Bumper

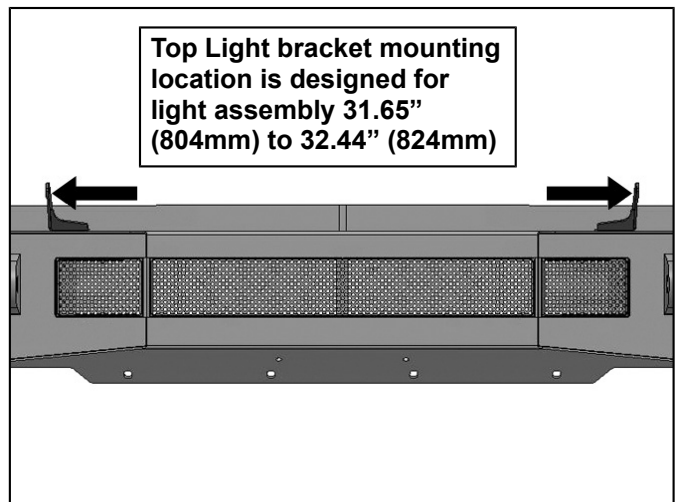

Top Light bracket mounting location is designed for light assembly 31.65" (804mm) to 32.44" (824mm)

(Fig 13) Measure width of LED light (light only) before installation of Top Light Brackets

Driver Side Installation Pictured

WARNING! Do not crawl under bumper unless the bumper is properly supported on blocks or stands or the bumper may fall.

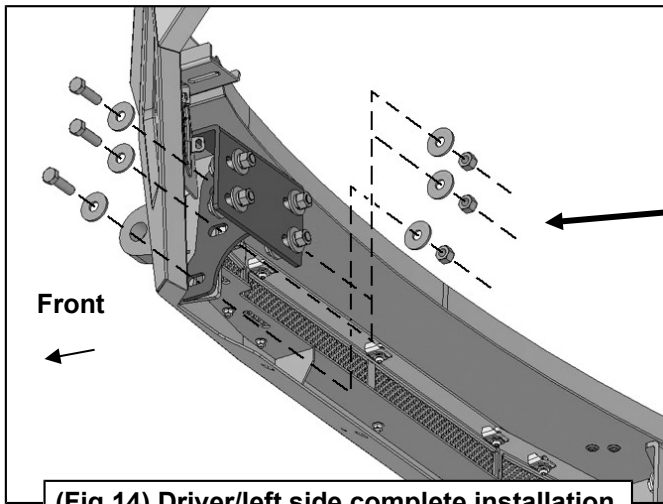

(Fig 14) Driver/left side complete installation

- (3) 12mm x 40mm Hex Bolts
- (6) 12mm x 37mm Large Flat Washers
- (3) 12mm Nylon Lock Nuts



(Fig 15) Driver/left side complete installation (pictured from below Bumper)

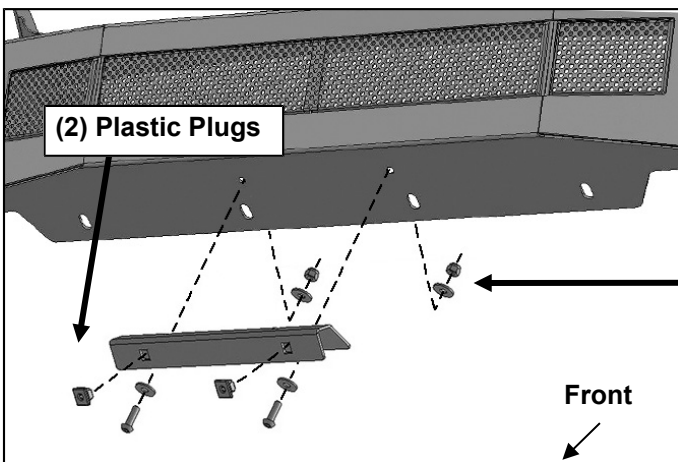

- (2) Plastic Plugs

- (2) 6mm Button Head Bolts
- (4) 6mm Flat Washers
- (2) 6mm Nylon Lock Nuts

(Fig 16) Attach License Plate Bracket to Bumper

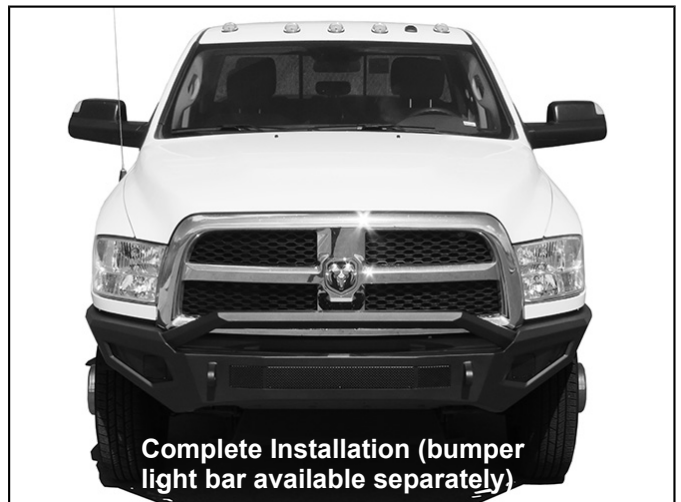

Complete Installation (bumper light bar available separately)