

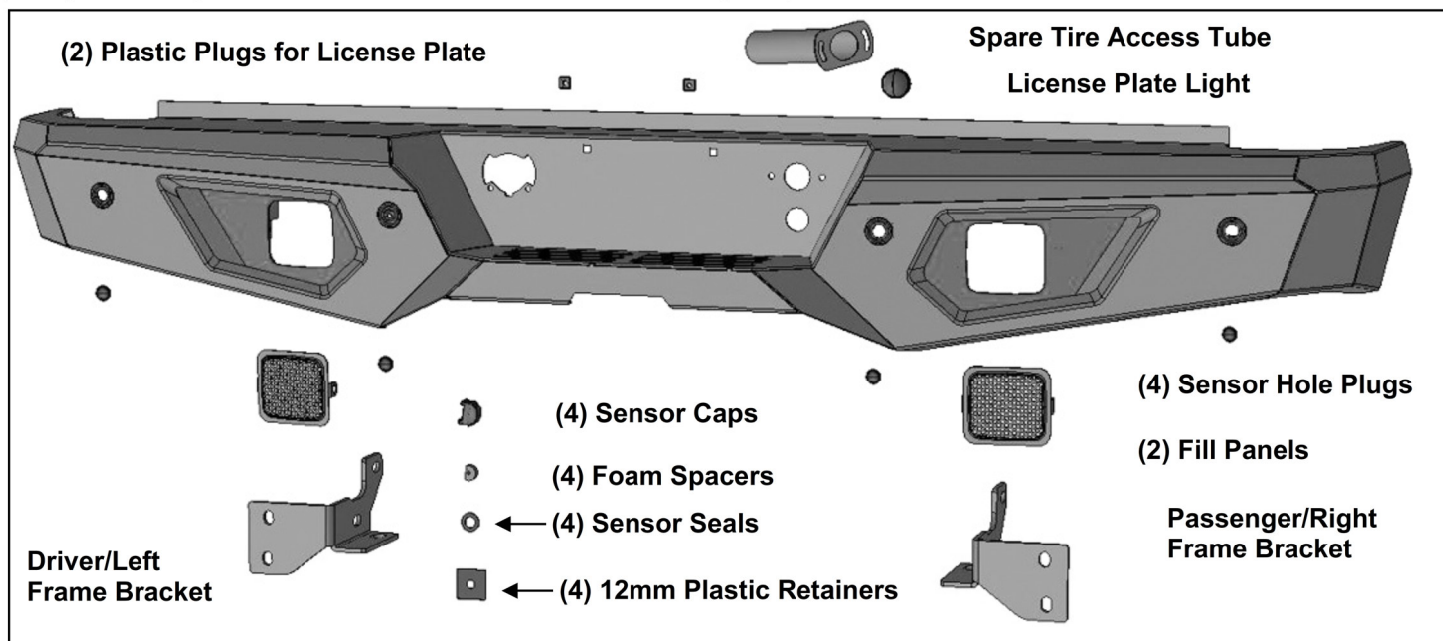

**PARTS LIST:**

1	LD2 Rear Bumper	4	12mm Plastic Retainers
1	Driver/Left Frame Bracket	4	12-1.75mm x 40 Hex Bolts
1	Passenger/Right Frame Bracket	8	12mm x 37mm x 3mm Flat Washers
2	Mesh Fill Panels	4	12mm Lock Washers
1	Spare Tire Access Tube	4	12mm Hex Nuts
1	License Plate Light	4	6-1.0mm x 20mm Combo Bolts
2	License Plate Plugs	2	6-1.0mm x 20mm Button Head Bolts
4	Sensor Hole Plugs	4	6mm x 12mm x 1.6mm Flat Washers
4	Sensor Retaining Caps	2	6mm Nylon Lock Nuts
4	20mm x 10mm Foam Spacers	4	6mm Flanged Nuts
4	15.5mm x 25mm x 2mm Sealing Washers	8	4mm Self Tapping Screws (sensors)
1	Sensor Cover Kit	1	4mm Hex Wrench
6	14-2.0mm x 45mm Hex Bolts	2	Self-Tapping Screws (trailer plug)
12	14mm x 28mm x 2.5mm Flat Washers	10	Nylon Wire Ties
6	14mm Nylon Lock Nuts		



**PROCEDURE:**

**REMOVE CONTENTS FROM BOX. VERIFY ALL PARTS ARE PRESENT. READ INSTRUCTIONS CAREFULLY BEFORE STARTING INSTALLATION. BUMPER IS HEAVY, ASSISTANCE IS HIGHLY RECOMMENDED TO AVOID POSSIBLE INJURY OR DAMAGE TO THE VEHICLE.**

1. Remove the license plate. On models with bumper sensors, unplug wiring harness leading to the bumper. Unplug and remove the trailer plug from the bumper.
2. Place blocks or jack stands under the bumper to support it during mounting bolt removal.
3. Starting on the Passenger/Right side
  - a. Remove (2) hex bolts attaching bumper to top/center of receiver hitch if equipped.
  - b. Remove hex bolts from side and bottom of the frame, **(Figures 1—3)**.
  - c. Repeat previous **Steps** to remove Driver/Left side hardware.
  - d. With assistance, pull bumper and brackets straight out from vehicle, **(Figures 4 & 5)**.
4. Select the Passenger/right Frame Bracket, **(Figure 6)**. Slide the Bracket into the end of the frame. Attach the Bracket to the forward hole in the side of the frame with (1) 10mm x 50mm Hex Bolt, (2) 10mm Flat Washers and (1) 10mm Nylon Lock Nut. Attach the Bracket to the side and bottom of the

frame with (2) 14mm x 45mm Hex Bolts, (4) 14mm Flat Washers and (2) 14mm Nylon Lock Nut, **(Figures 6 & 7)**. Do not tighten hardware at this time. **NOTE:** On some models/years, the factory tow hitch may have support straps attached to the outside of the frame. Use the included (1) 14mm x 45mm Hex Bolt, (2) 14mm Flat Washers and (1) 14mm Nylon Lock Nut to attach the top hole in the strap to the top mounting hole, **(Figures 5 & 8)**. Bottom hole in strap is attached to Bumper Bracket.

5. Repeat **Step 4** to install the driver/left Frame Bracket.
6. Remove wiring harness from bumper:
7. Determine if the vehicle is equipped with sensors.

**Models without bumper sensors:**

- a. Select the included (4) Plastic Plugs. Push Plugs into sensor mounting holes, **(Figure 9)**.
- b. Install wiring harness for license plate lights.

**Models with bumper mounted sensors:**

- a. Remove sensors from factory bumper.
- b. Remove the silicone seal from the end of the sensor. Slide the included larger Sensor Seal over front of sensor, **(Figure 10)**.
- c. Insert sensor with Seal into sensor mount, **(Figure 11)**.
- d. Place Foam Spacer over end of sensor. Push Sensor Retaining Cap onto sensor mount and lock into mounting holes, **(Figure 11)**.
- e. Repeat previous **Steps** to install remaining sensors.
- f. Install and plug in wiring harness for license plate lights and sensors.
- g. **Optional:** Secure each sensor to the socket with (2) 4mm x 10mm Button Head Screws. **IMPORTANT:** Sensors fit snug in sockets. The 4mm Screws are used to apply slight pressure to lock the sensors in place. Tighten both screws evenly until they touch the sensor body only. Do not overtighten screws or damage to sensors will result.

8. Determine if accessory lights, (not included), or Mesh Fill Panels will be installed at this time.

**Mesh Fill Panel Installation (do not install fill panels if installing lights).**

- a. Select the Fill Panels.
- b. Attach Panels with the included 6mm Combo Bolts and 6mm Flange Nuts, **(Figure 12)**. Fully tighten Mesh Panel hardware at this time.

**LED cube style light installation (light not included).**

- a. Attach lights to mounting tabs on back of each end of the Bumper, **(Figure 12)**.
9. Select the Spare Tire Access Guide. Attach the Guide to the back of the bumper with (2) 6mm Button Head Bolts, (4) 6mm Flat Washers and (2) 6mm Nylon Lock Nuts, **(Figure 13)**.
10. Insert the included (4) 12mm x 35mm Hex Bolts with (4) 12mm Flat Washers into and through the mounting plates on the Bumper. Thread (4) 12mm Plastic Retainers onto the (4) Hex Bolts to help hold them in place, **(Figure 14)**. Temporarily support the weight of the Bumper. **WARNING:** To avoid possible injury or damage to the vehicle, do not proceed until the Bumper is fully and safely supported.
11. With assistance, position the Bumper Assembly up to the Frame Brackets. Attach the Bumper to the Brackets with the included (4) 12mm Flat Washers, (4) 12mm Lock Washes and (4) 12mm Hex Nuts, **(Figure 15)**. Do not fully tighten hardware at this time.
12. Level and adjust the Bumper and fully tighten all hardware. Slowly open tailgate and check for clearance. Adjust as necessary.
13. Use the included (2) push-in Plastic Plugs to attach the rear license plate to the (2) holes in the Bumper. Insert the License Plate Light into the hole in the Bumper, **(Figure 16)**. Attach the License Plate Light wires to the end of the factory wire harness.
14. Use the included (2) Self Tapping Screws to attach the trailer plug, if equipped, to the Bumper, **(Figure 17)**. Attach the wiring harness to the lights and trailer plug.
15. Use the included Wire Ties to secure the wiring harness to the bumper and frame as necessary.
16. Do periodic inspections to the installation to make sure that all hardware is secure and tight.

**To protect your investment,** Do not use any type of polish or wax that may contain abrasives that could damage the finish. Mild soap may be used to clean the Bumper assembly.

**Passenger/Right side installation pictured**

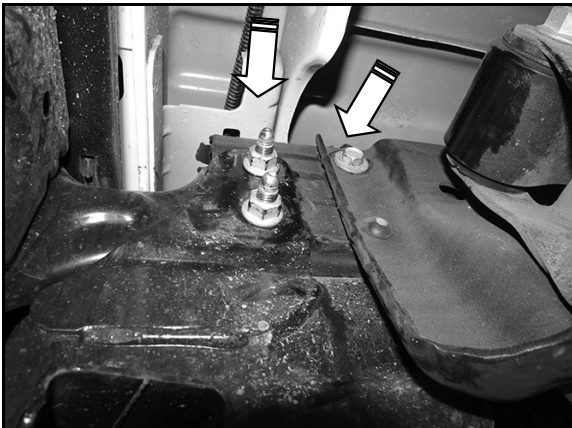

**(Fig 1) Remove bumper bolts from outside of frame (arrows). Passenger/Right pictured from below**

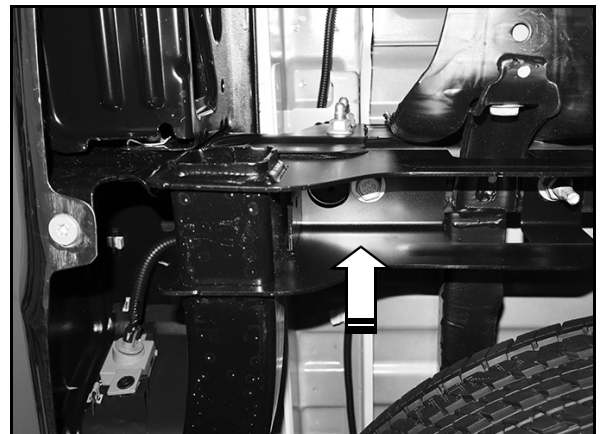

**(Fig 2) Remove bumper bolt from bottom of frame (arrow). Back of Passenger/Right side of model w-o receiver hitch pictured from below**

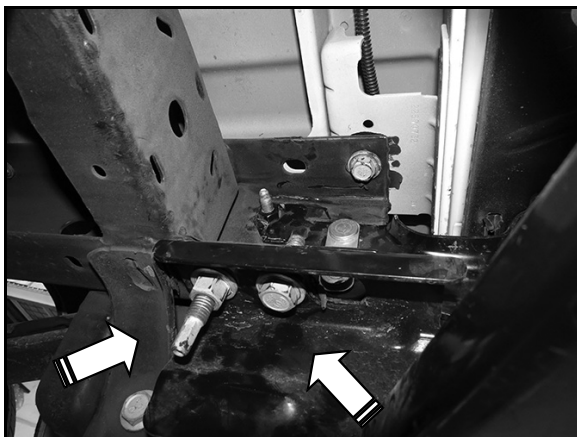

**(Fig 3) Remove bumper bolts attaching brackets to frame (arrows). Model with receiver hitch pictured**

**WARNING! Before removing hardware, fully support the weight of the bumper with blocks or stands to prevent injury or damage to the vehicle.**

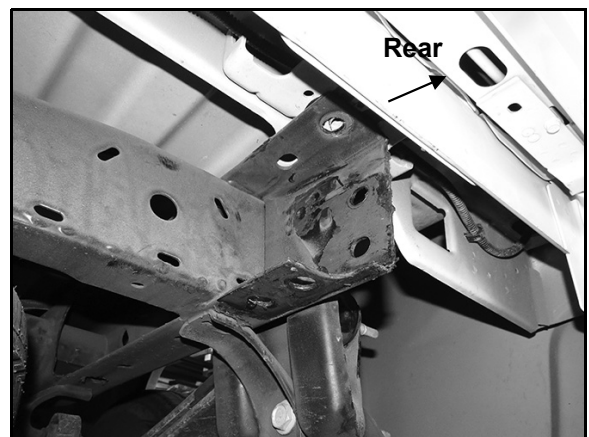

**(Fig 4) Frame once bumper is removed. Passenger/right side w-o receiver hitch pictured**

Passenger/Right side installation pictured



(Fig 5) End of frame once bumper is removed. Passenger/right side with receiver hitch

**WARNING!** Before removing hardware, fully support the weight of the bumper with blocks or stands to prevent injury or damage to the vehicle.

10mm x 50mm Hex Bolt  
(2) 10mm Flat Washers  
10mm Nylon Lock Nut

14mm x 45mm Hex Bolt  
(2) 14mm Flat Washers  
14mm Nylon Lock Nut

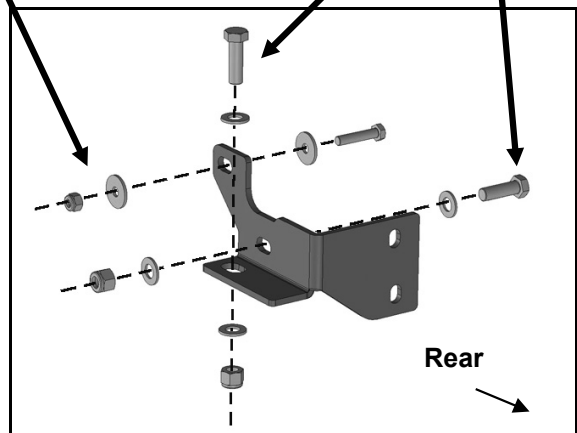

(Fig 6) Attach Bumper Bracket to mounting holes in frame and hitch if equipped

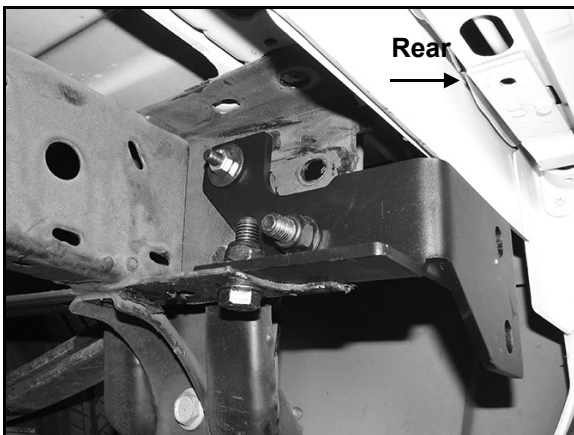

(Fig 7) Attach Passenger/Right of Bumper to frame. Model w-o receiver hitch pictured

14mm x 45mm Hex Bolt  
(2) 14mm Flat Washers  
14mm Nylon Lock Nut

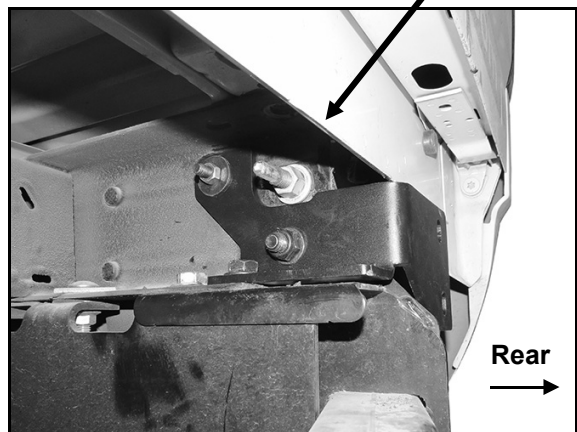

(Fig 8) Model with receiver hitch with support strap pictured (also see Fig 7)

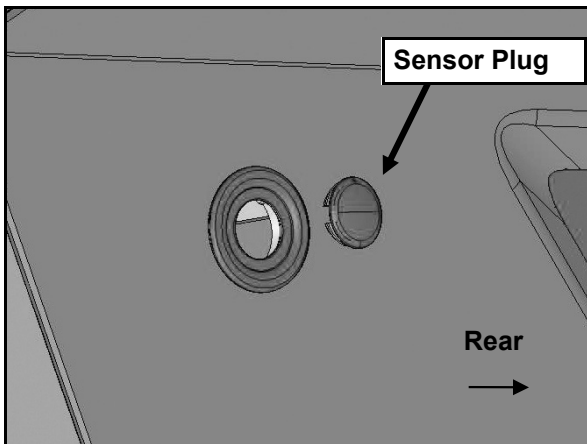

(Fig 9) Push Sensor Plug into sensor mount

Passenger/Right side installation pictured

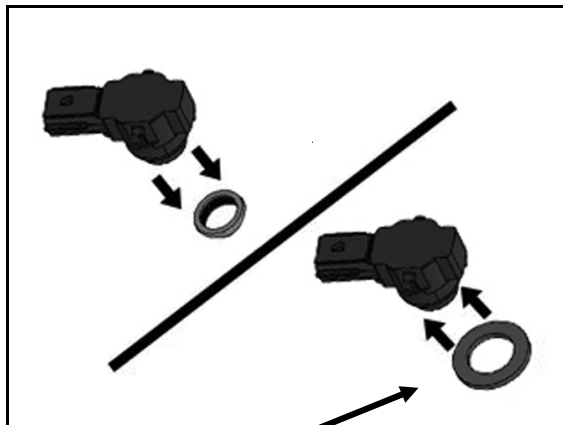

(Fig 10) Remove silicone seal from sensor. Slide large Seal over end of sensor (arrow)

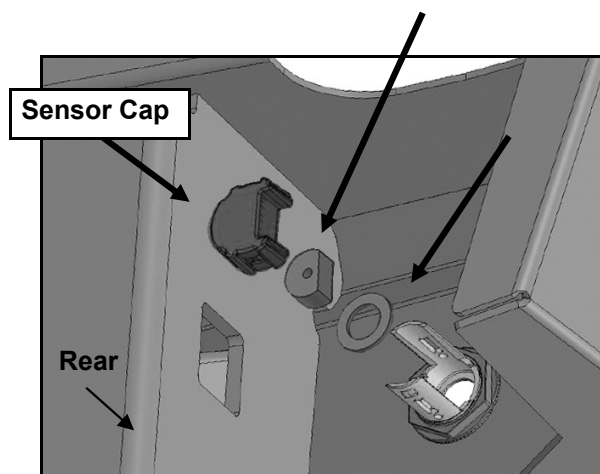

(Fig 11) Slide sensor into Mount, insert Foam Spacer and Cap to lock sensor in mount

- (2) 6mm Combo Bolts
- (2) 6mm Flange Nuts

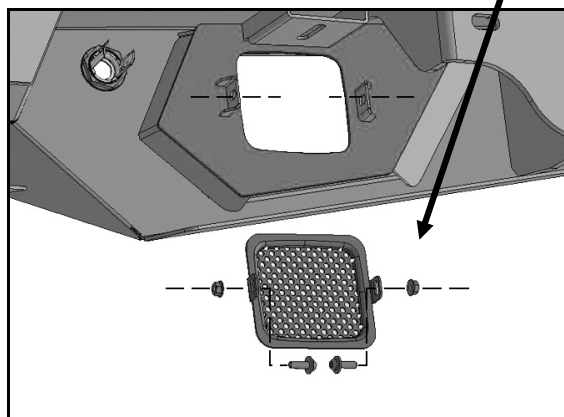

(Fig 12) Attach LED light (not included) to tab or install Fill Panel before installing Bumper

- (2) 6mm x 20mm Button Head Bolts
- (4) 6mm Flat Washers
- (2) 6mm Nylon Lock Nuts

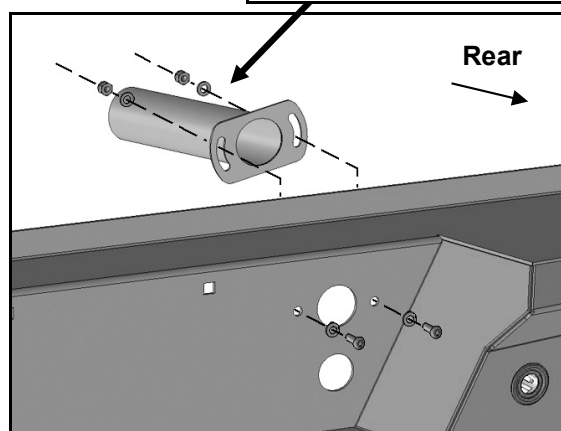

(Fig 13) Attach the Spare Access Tube to the back of the bumper

Passenger/Right side installation pictured

(2) 12mm x 55mm Hex Bolts  
(2) 12mm Flat Washers

(2) 12mm Plastic Retainers

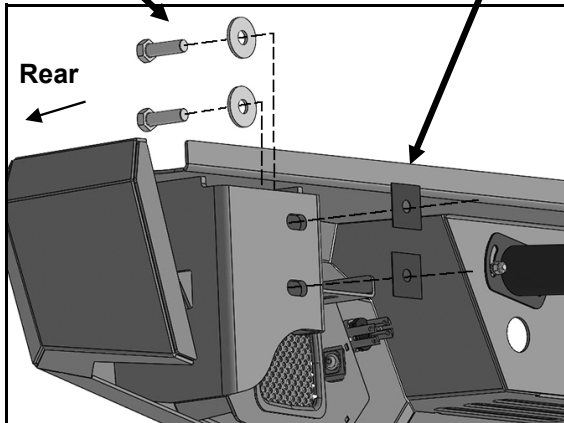

(Fig 14) Use the (2) 12mm Plastic Retainers to hold the (2) 12mm Bolts in the Bumper

**WARNING!** Before installation, fully support the weight of the bumper with blocks or stands to prevent injury or damage to the vehicle.

(2) 12mm Flat Washers  
(2) 12mm Lock Washers  
(2) 12mm Hex Nuts

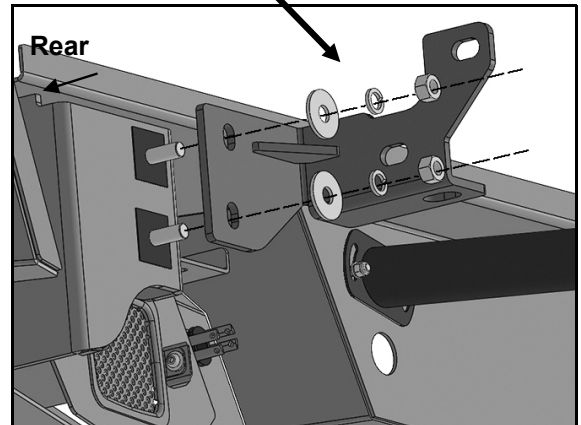

(Fig 15) Attach Bumper to Frame Brackets

(2) License plate mounting plugs

License plate light

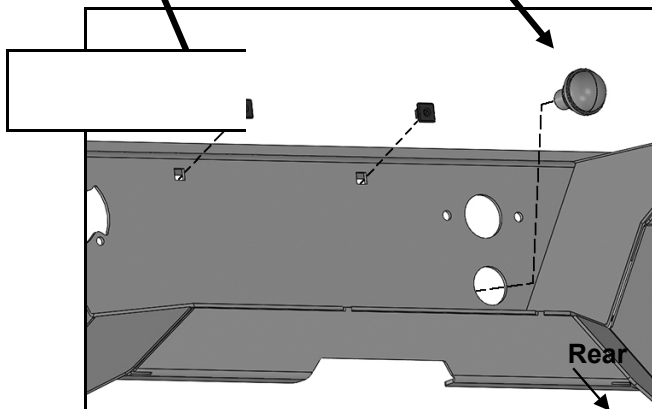

(Fig 16) Insert Plugs for license plate. Insert License Plate Light

(2) Self Tapping Screws

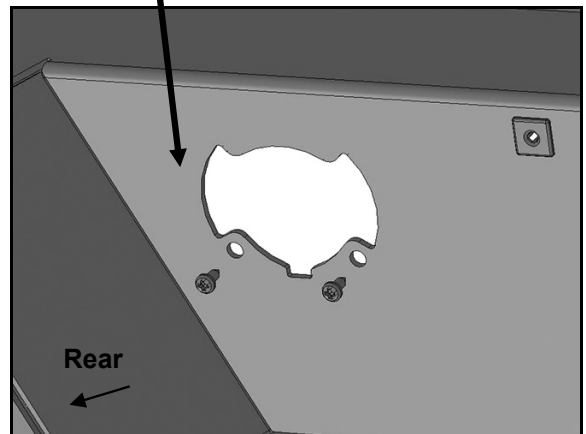

(Fig 17) Attach trailer plug, if equipped, with included Self Tapping Screws