

PARTS LIST:

| | | | |
|---|----------------------------------|----|----------------------------------|
| 1 | X-Series Front Bumper | 10 | 12mm Lock Washers |
| 1 | Bull Nose Hoop | 8 | 12mm Hex Nuts |
| 1 | Winch Tray | 2 | 10mm x 25mm Hex Bolts |
| 2 | LED light Brackets | 2 | 10mm x 30mm x 2.5mm Flat Washers |
| 1 | License Plate Bracket | 2 | 10mm Lock Washers |
| 2 | License Plate Plugs | 4 | 8-1.25mm x 25mm Hex Bolt |
| 8 | 12mm Plastic Retainers | 4 | 8mm x 16mm x 1.6mm Flat Washers |
| 4 | 12mm x 40mm Double Bolt Plates | 4 | 8mm Lock Washers |
| 2 | 12mm Nut Plates | 4 | 8mm Flange Nuts |
| 2 | 12mm x 30mm Hex Bolts | 2 | 6-1.0mm x 20mm Combine Bolt |
| 2 | 12mm x 24mm x 2.5mm Flat Washers | 2 | 6mm Flange Nuts |
| 8 | 12mm x 37mm x 3mm Flat Washers | 1 | 4mm Wrench |
| | | 10 | Nylon Wire Ties |

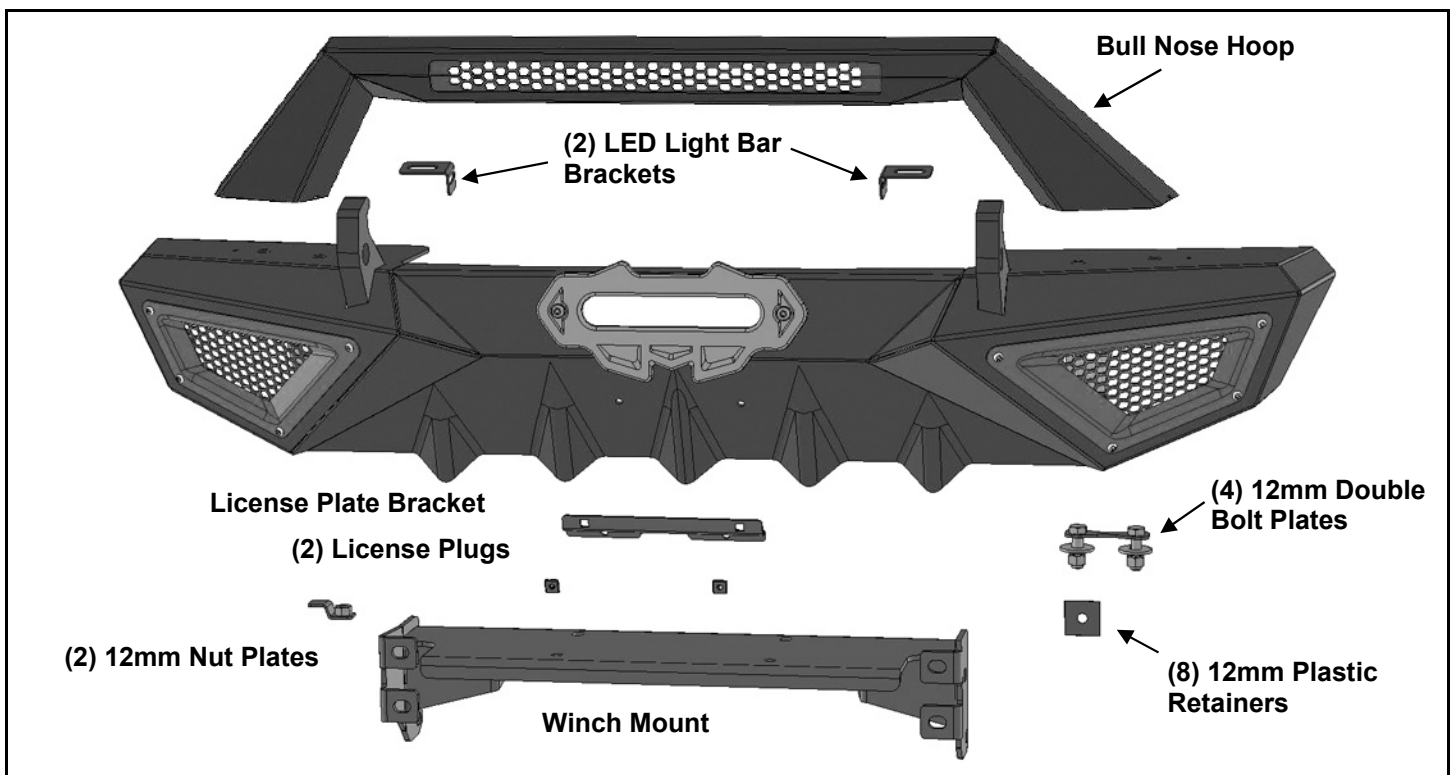

PROCEDURE:

REMOVE CONTENTS FROM BOX. VERIFY ALL PARTS ARE PRESENT. READ INSTRUCTIONS CAREFULLY BEFORE STARTING INSTALLATION. ASSISTANCE IS RECOMMENDED.

1. Start under the front bumper of the vehicle and remove the plastic lower splash guard or steel skid plate, **(Figure 1)**. **NOTE:** Splash guard or skid plate cannot be reinstalled.
2. Unplug the fog light wiring harness leading to the bumper, **(Figure 2)**.
3. With assistance, remove the front bumper, **(Figures 3—5)**. Move the bumper to a stable surface.
4. Remove the passenger and driver side inner bumper support brackets from the side of the frame, **(Figures 4 & 5)**. **IMPORTANT:** Only remove the inner support brackets, leave the outer brackets in place. The inner support brackets will not be reinstalled. **NOTE:** On models with electric sway bar disconnect, it may be easier to temporarily remove the sway bar to access the Bumper and winch hardware from below.
5. Select the Winch Mount, (installation is optional). Attach the Winch Mount to the threaded holes in the side of the frame with the included (1) 10mm Hex Bolt, (1) 10mm Lock Washer and (1) 10mm Flat Washer, **(Figure 6)**. Select (1) 12mm Nut Plate. Insert the Nut Plate into the opening in the front of the driver/left side of the frame, **(Figure 5)**. Attach the Winch Mount to the Nut Plate with (1) 12mm x 30mm Hex Bolt, (1)

12mm Lock Washer and (1) 12mm x 24mm Small Flat Washer, (**Figures 6 & 7**). Repeat this Step to attach the passenger/right side of the Winch Mount to the frame and Nut Plate. Do not fully tighten hardware at this time. Follow the manufacturer's instructions to properly attach the winch to the top of the bumper and to connect the winch to the electrical system.

6. Determine if Bull Nose Hoop will be installed, (optional). **NOTE:** Bull Nose Hoop must be attached to the Front Bumper before installing the Bumper. If Bull Nose Hoop will not be installed, skip to **Step 7**.

Bull Nose Hoop Installation, (optional):

- a. Remove (4) Rubber Plugs from the top of the Bumper, (**Figure 8**).
- b. Select the Bull Nose Hoop. Attach the Hoop to the top of the Bumper with the included (4) 8mm x 25mm Hex Bolts, (4) 8mm Lock Washers and (4) 8mm Flat Washers and (4) 8mm Flange Nuts, (**Figure 8**).

LED light bar installation in Bull Nose Hoop, (LED light bar sold separately).

- a. Remove the Fill Panel from the top of the Bull Nose Hoop, (**Figure 9**). **NOTE:** Fill Panel cannot be installed with LED Light.
- b. Select the included (2) LED "L" Light Brackets. Reuse the hardware from the Fill Panel to attach the LED Brackets to the mounting tabs on the back of the Bull Nose Hoop, (**Figure 10**).
- c. Next, attach the light bar to the Brackets.

7. Light installation in outer ends of Bumper, (lights sold separately).

- a. Remove the Fill Panel from the driver/left side of the Bumper, (**Figure 11**). **NOTE:** Fill Panel cannot be installed with light.
- b. Attach light to the mounting tab on the back of the Bumper. **NOTE:** Outer trim ring can also be removed if desired.
- c. Repeat previous Steps to attach the passenger/right light. Follow instructions included with lights to attach to vehicle electrical system.

8. Select (1) 12mm Double Bolt Plate and (2) 12mm Plastic Retainers. Insert the Bolt Plate into the back of the Bumper and back out through the (2) vertical holes in the mounting flange welded into the Bumper, (**Figure 12**). Thread the Plastic Retainers onto and down the threaded end of the Bolt Plate to hold the Bolt Plate in place during Bumper installation. **IMPORTANT:** The Plastic Retainers are used to help hold the Bolt Plate in place but use is not mandatory. Repeat this Step to install the remaining (3) 12mm Double Bolt Plates.

9. With assistance, hold the Bumper up in against the end of the frame and Winch Mount if desired. Attach the Bolt Plate in the Bumper to the frame with the included (8) 12mm x 37mm Large Flat Washers, (8) 12mm Lock Washers and (8) 12mm Hex Nuts, (**Figures 13—15**). Do not fully tighten hardware at this time.

10. Stand back from the vehicle and check to see that the Bumper is centered and level on the vehicle and adjust as required. Once properly aligned, fully tighten all hardware.

11. Attach the License Plate Bracket (if needed) to the front of the Bumper with the included (2) 6mm Combo Bolts and (2) 6mm Flange Nuts. Push (2) Plastic Plugs into square holes in Bracket to attach license plate, (**Figure 16**).

12. Reinstall electric sway bar if equipped and previously removed.

13. Do periodic inspections of the installation to make sure that all hardware is secure and tight.

To protect your investment, Do not use any type of polish or wax that may contain abrasives that could damage the finish. Mild soap may be used to clean the Front Bumper.



(Fig 1) Remove plastic splash guard if equipped

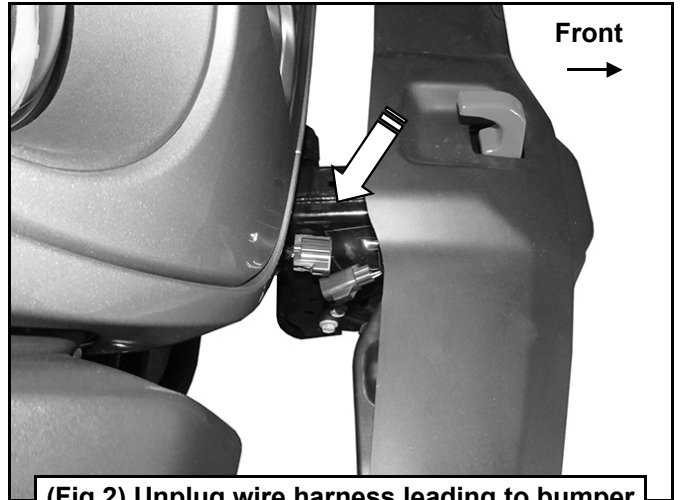

(Fig 2) Unplug wire harness leading to bumper

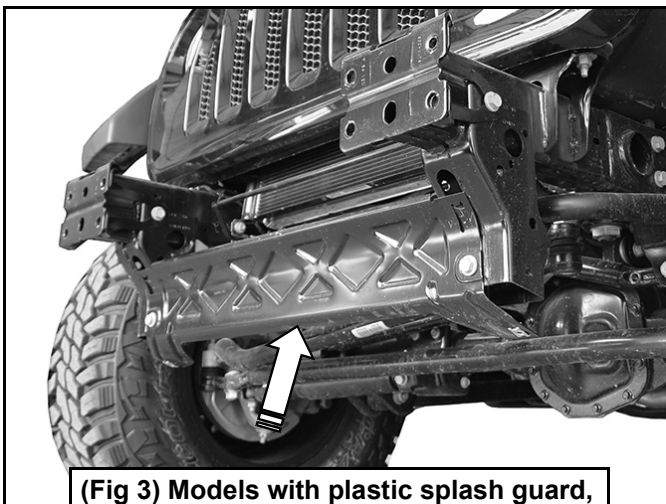

(Fig 3) Models with plastic splash guard, remove frame bracket (arrow)

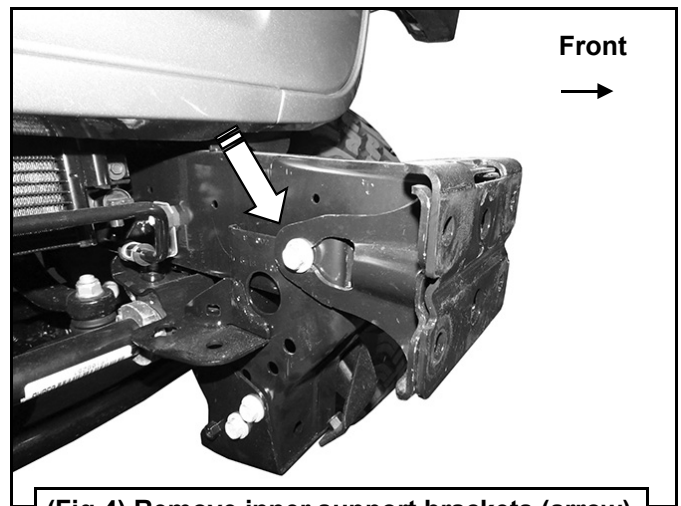

(Fig 4) Remove inner support brackets (arrow)

X-SERIES FRONT BUMPER
2018-22 JEEP JL/2020-22 GLADIATOR
INCL. 2020-22 JL DIESEL ENGINE & EXCL. PLUG-IN HYBRID MODELS

Driver/left Side Installation Pictured

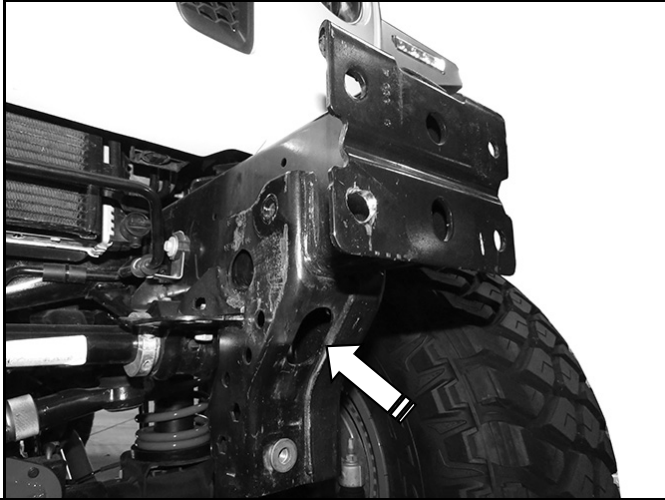

(Fig 5) Insert 12mm Nut Plate into opening in frame (arrow). Line up Nut with hole in side of frame

- (1) 12mm Nut Plate
- (1) 12mm Lock Washer
- (1) 12mm x 24mm Small Flat Washer

- (1) 10mm x 25mm Hex Bolt
- (1) 10mm Lock Washer
- (1) 10mm Flat Washer

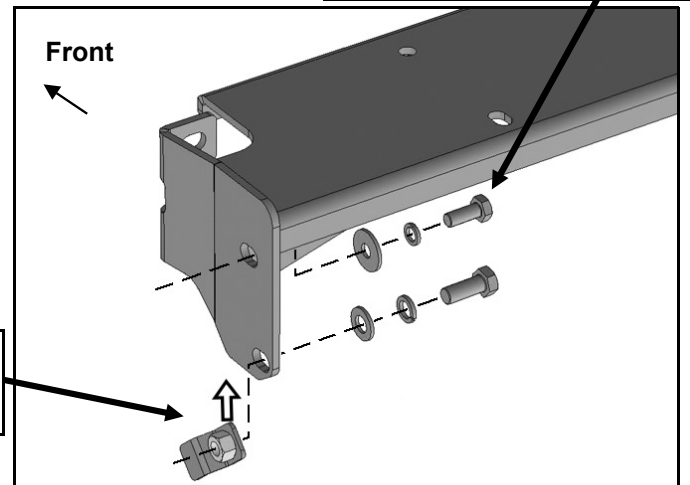

(Fig 6) Attach Winch Mount to 12mm Nut Plate in frame and factory threaded hole for bumper support



(Fig 7) Attach Winch Mount to side of frame (driver/left side pictured)

- (2) 8mm x 25mm Hex Bolts
- (2) 8mm Lock Washers
- (2) 8mm Flat Washers
- (2) 8mm Flange Nuts

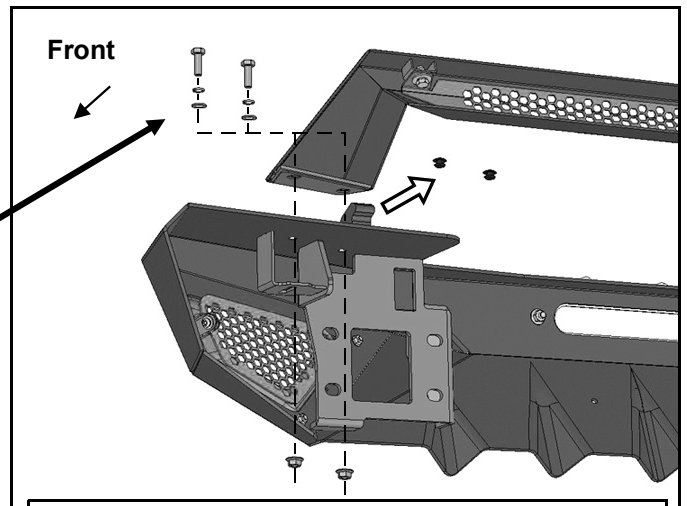

(Fig 8) Remove rubber plugs to attach Bull Nose hoop to top of Bumper (driver/left side pictured)

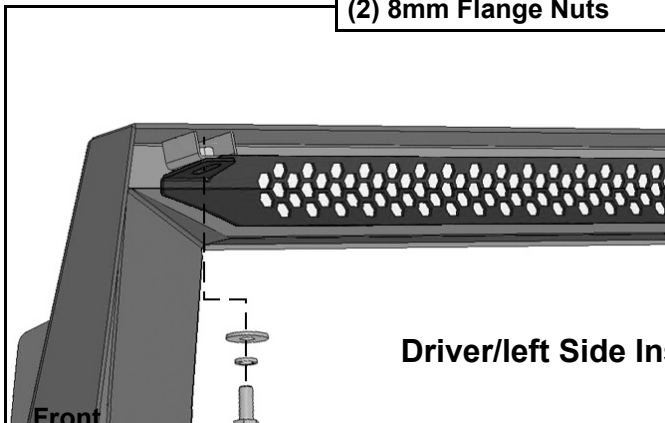

Driver/left Side Installation Pictured

(Fig 9) Remove fill panel from back of Bull Nose hoop to install LED light (light is optional-not included)

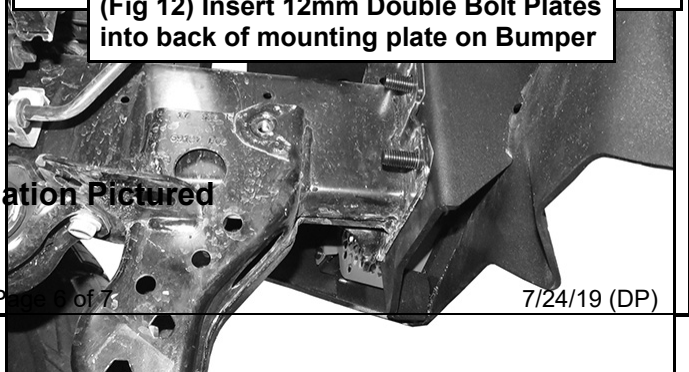
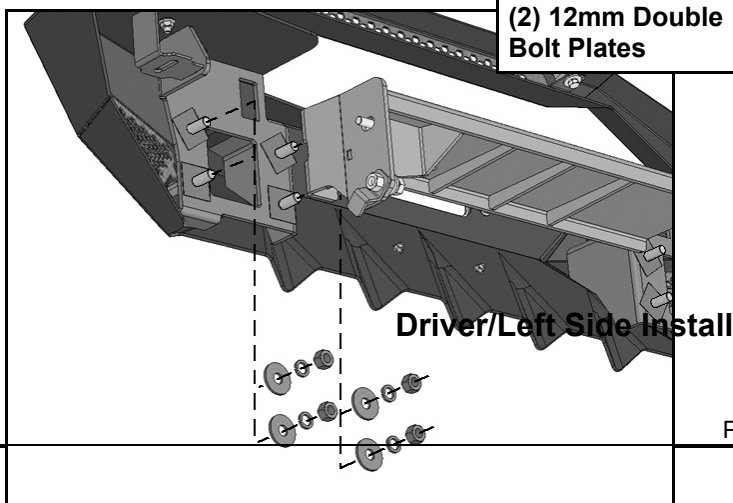
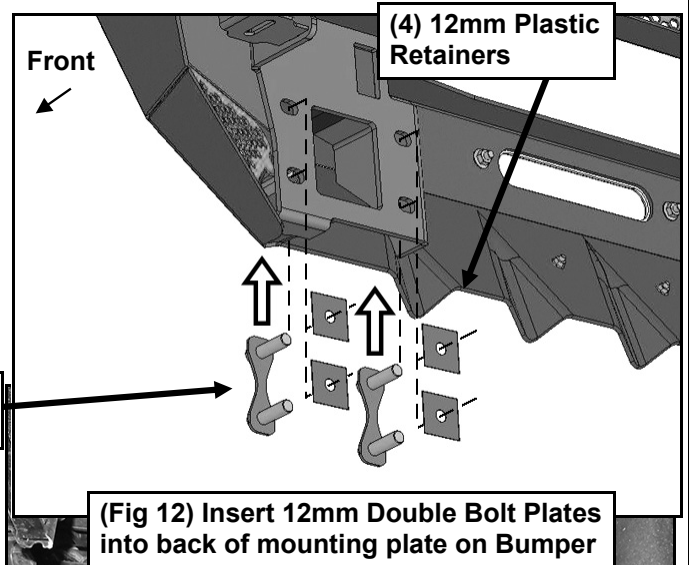
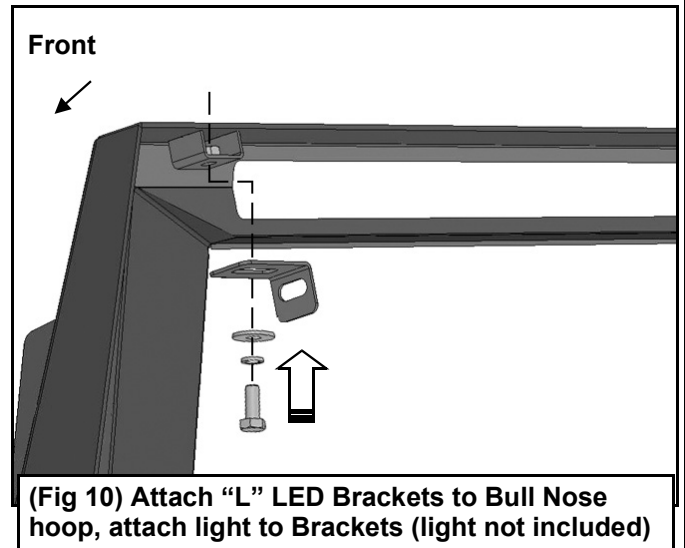
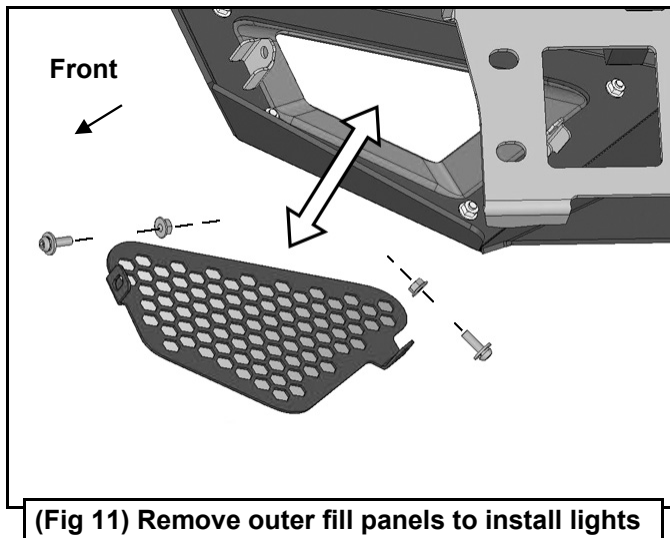

X-SERIES FRONT BUMPER
2018-22 JEEP JL/2020-22 GLADIATOR
INCL. 2020-22 JL DIESEL ENGINE & EXCL. PLUG-IN HYBRID MODELS

- (4) 12mm x 37mm Large Flat Washers
- (4) 12mm Lock Washers
- (4) 12mm Hex Nuts

Front
←

(Fig 13) Attach driver/left side of Bumper to Winch Mount and frame

- (1) 12mm Nut Plate
- (1) 12mm Lock Washer
- (1) 12mm x 32mm STD Flat Washer

Front
→

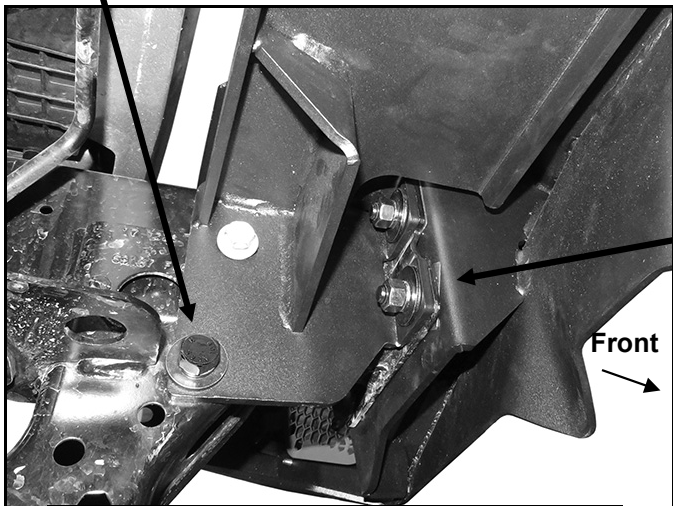

(Fig 14) Driver/left side of Bumper pictured without Winch Bracket

- (4) 12mm x 37mm Large Flat Washers
- (4) 12mm Lock Washers
- (4) 12mm Hex Nuts

(Fig 15) Driver/left side of Bumper pictured with Winch Bracket installed

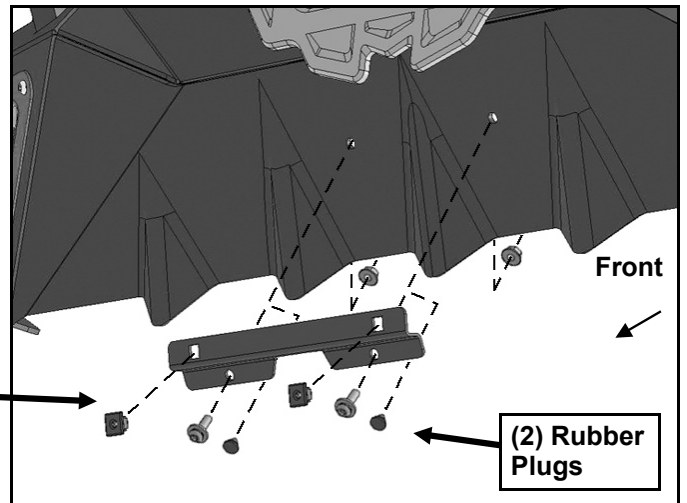

- (2) 6mm Combo Bolts
- (2) 6mm Flange Nuts
- (2) Plastic Plugs

- (2) Rubber Plugs

(Fig 16) Remove rubber plugs to attach License Plate Bracket to front of Bumper