

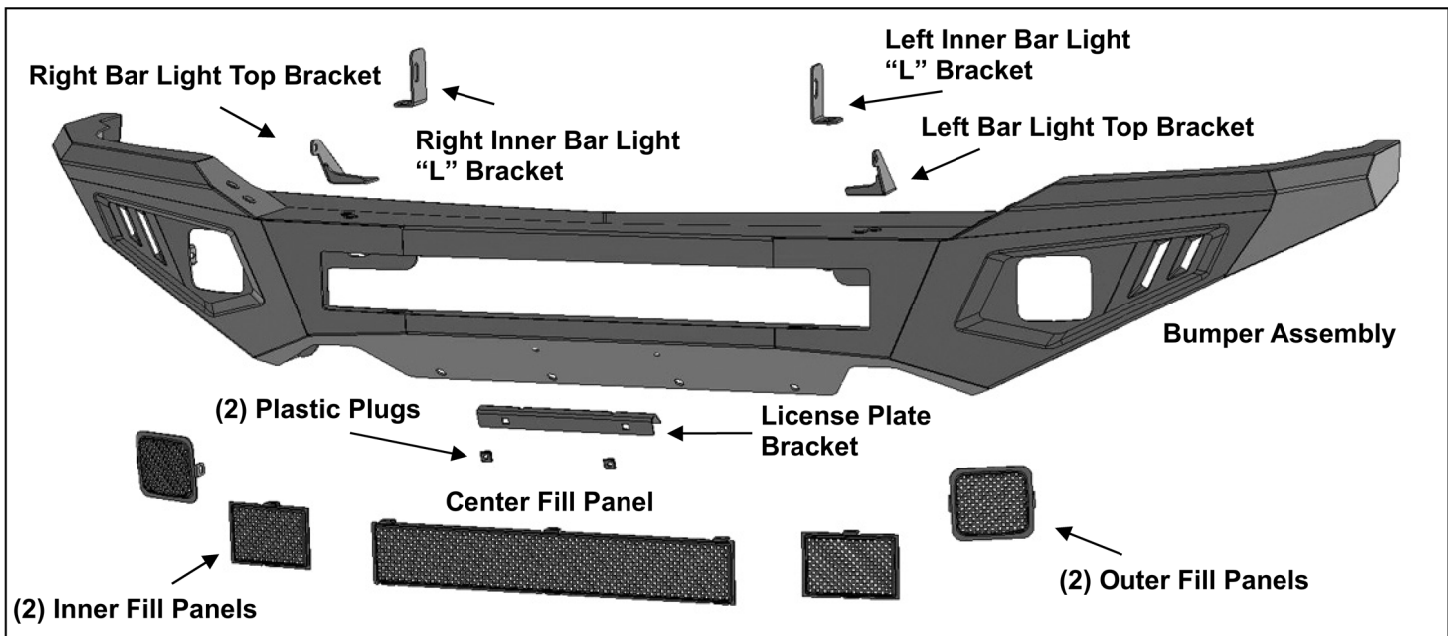

**PARTS LIST:**

**X3B-CSIL32-FB**

1	LD2 Front Bumper Assembly	14	8mm x 24mm x 2mm Flat Washers
1	Long Center Fill Panel	8	8mm Lock Washer
2	Small Inner Fill Panels	6	8mm Hex Nut
2	Small Outer Fill Panels	14	6-1.0mm x 20mm Combo Bolt
1	License Plate Bracket	14	6mm Flange Nut
2	Plastic Plugs for License Plate	2	6mm x 20mm Button Head Bolts
1	Driver/left Light Bar Bracket (Top LED light)	2	6mm x 16mm Hex Bolts
1	Passenger/right Light Bar Bracket (Top LED light)	6	6mm x 18mm x 1.6 Flat Washers
1	Driver/left "L" Light Bar Bracket (Inner LED light)	2	6mm Lock Washer
1	Passenger/right "L" Light Bar Bracket (inner LED light)	2	6mm Nylon Lock Nuts
4	8mm x 25mm Button Head Bolts	1	5mm Wrench
2	8mm x 16mm Hex Bolts	1	4mm Wrench



**PROCEDURE:**

**REMOVE CONTENTS FROM BOX. VERIFY ALL PARTS ARE PRESENT. READ INSTRUCTIONS CAREFULLY BEFORE STARTING INSTALLATION. ASSISTANCE IS RECOMMENDED TO AVOID POSSIBLE INJURY OR DAMAGE TO THE VEHICLE.**

1. Remove the license plate and bracket. On models with factory fog lights and/or bumper sensors, unplug the wiring harness leading to the bumper, **(Figure 1)**. Move harness away from bumper.
2. Next, locate and remove the screws attaching the ends of the plastic body panel, (fascia), to the fenders. **NOTE:** Fascia body panel fills the area between the headlights and the top of the bumper. From behind the bumper, release the clips attaching the fascia body panel to the bottom of the grille and remove the panel. **(Figure 2)**.
3. Next, open the hood and remove the plastic cover between the top of the radiator and the grille, **(Figure 3)**. Next, carefully remove the grille from the vehicle. **NOTE:** Grille is held in place with screws at the top and several clips. Remove the screws and firmly pull the grille straight out from the vehicle to release the grille from the clips, **(Figure 3)**.
4. From behind the bumper, disconnect the outer supports on each end of the bumper, **(Figure 8)**.
5. Place blocks or jack stands under the front bumper to support it during mounting bolt removal. Once the bumper has been safely supported, remove the bumper bolts attaching the bumper assembly to the

**LD2 FRONT BUMPER  
2014-15 CHEVY SILVERADO 1500**

frame bracket bolted to the end of the frame, **(Figure 4)**. **WARNING!** Assistance is required to hold the bumper in place during bolt removal to prevent the bumper from falling. Carefully slide the bumper assembly off of the ends of the frame.

6. Once bumper has been removed, reinstall the plastic grille and cover removed in **Step 3**.
7. Remove both bumper brackets from the ends of the frame, **(Figures 5 & 6)**. **NOTE:** Do not remove the tow hooks if equipped.
8. Remove the plastic brackets from the bottom of the headlight assemblies, **(Figure 7)**. Also remove the outer bumper support brackets from driver and passenger side if still attached, **(Figure 8)**.
9. Carefully unwrap the Bumper assembly. Determine if accessory lights, (not included), or Screen Fill Panels will be installed at this time. **IMPORTANT:** It may be easier to install Center Fill Panels and/or lights before installing Bumper.

**Screen Fill Panel Installation (do not install fill panels if installing lights).**

- a. Select desired Screen Fill Panels. **NOTE:** Outer Panels are square with rounded corners, Inner panels are rectangular with sharp corners, **(Figure 9)**.
- b. Attach Screen Fill Panels as needed with the included 6mm Button Head Combo Bolts and 6mm Flange Nuts, **(Figures 9 & 10)**. Fully tighten Fill Panel hardware at this time. Repeat to install all Panels as desired.

**Inner center LED bar style light installation (light not included).**

- a. Select the driver/left "L" Light Bar Bracket. **NOTE:** "L" Brackets are offset to adjust for different widths of LED Bar Lights and can be installed on either side as needed.
- b. Attach the L Bracket to the slot on the back of the Bumper with (1) 8mm x 25mm Hex Bolt, (2) 8mm Flat Washers, (1) 8mm Lock Washer and (1) 8mm Hex Nut, **(Figure 11)**. Repeat this Step to install the remaining "L" Bracket on the other side of the Bumper. **IMPORTANT:** The Bumper features slots designed for 20" and 30" bar style lights. Attach the Brackets to the correct slots in the Bumper. If necessary, hold the light up to the slots to help determine correct slots to use and combination of Brackets.
- c. Attach the light to the "L" Brackets with the hardware included with the light or the supplied (2) 8mm x 16mm Hex Bolts, (2) 8mm Lock Washers and (2) 8mm Flat Washers or (2) 6mm x 16mm Hex Bolts, (2) 6mm Lock Washers and (2) 6mm Flat Washers, **(Figures 11 & 12)**. Do not fully tighten hardware at this time.

**Top mounted 30" bar style LED light (not included).**

- a. Remove the (2) rubber plugs from the driver/left side mounting holes, **(Figure 13)**.
- b. Select the driver/left Light Bracket. Attach the Bracket to the top of the Bumper with (2) 8mm x 25mm Button Head Bolts, (4) 8mm Flat Washers, (2) 8mm Lock Washers and (2) 8mm Hex Nuts, **(Figure 13)**. Do not tighten hardware at this time.
- c. Repeat previous Steps to attach the passenger/right Bracket.
- d. Select the 30" light, (not included). Attach light to Top Brackets with the hardware included with the light. Adjust the width of the Brackets to the light and fully tighten bracket hardware.  
**IMPORTANT:** Top Light Brackets are designed to install 30" bar style LED lights with outside length dimensions of 31.653" (804mm) to 32.44" (824mm) only, **(Figure 14)**. Fully tighten top light hardware once adjusted.

**Outer LED cube style light installation (light not included).**

- a. Attach lights to mounting tabs on back of each end of the Bumper, **(Figure 16)**.
10. With assistance, position the Bumper Assembly up to the ends of the frame. Temporarily support the weight of the Bumper. **WARNING:** To avoid possible injury or damage to the vehicle, do not proceed until the Bumper is fully and safely supported.
11. Line up the (2) upper slots in the driver/left side mounting plate on the back of the Bumper with the mounting holes in the end of the frame. Reuse the factory bolts to attach the Bumper to the plate, **(Figures 15 & 16)**. Repeat this **Step** to attach the passenger/right side of the Bumper to the frame.
12. Level and adjust the bumper and fully tighten all hardware.
13. If front license plate is required, attach the License Plate Bracket to the holes in the bumper with the included (2) 6mm x 20mm Button Head Screws, (4) 6mm Flat Washers and (2) 6mm Nylon Lock Nuts. Insert (2) Plastic Plugs into the square holes in the Bracket. Reuse the factory screws to attach the license plate to the plastic plugs, **(Figure 17)**.

14. Do periodic inspections to the installation to make sure that all hardware is secure and tight.

To protect your investment, Do not use any type of polish or wax that may contain abrasives that could damage the finish. Mild soap may be used to clean the Front Bumper assembly.

### Driver/left Side Installation Pictured

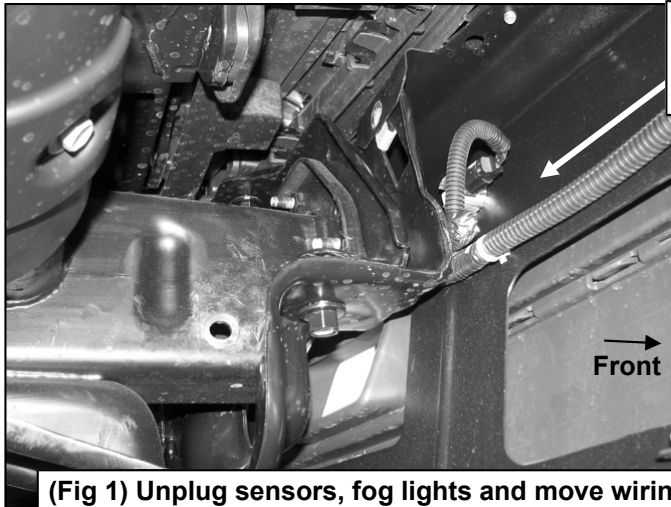

Unplug harness leading sensors and fog lights if equipped

(Fig 1) Unplug sensors, fog lights and move wiring harness away from bumper before removal



(Fig 2) From behind bumper, release clips along the center and the hardware at the fenders attaching the plastic fascia panel (arrow) to top of bumper. Remove fascia panel to access bumper hardware



(Fig 3) Remove plastic cover from top of radiator (arrow). Temporarily remove grille

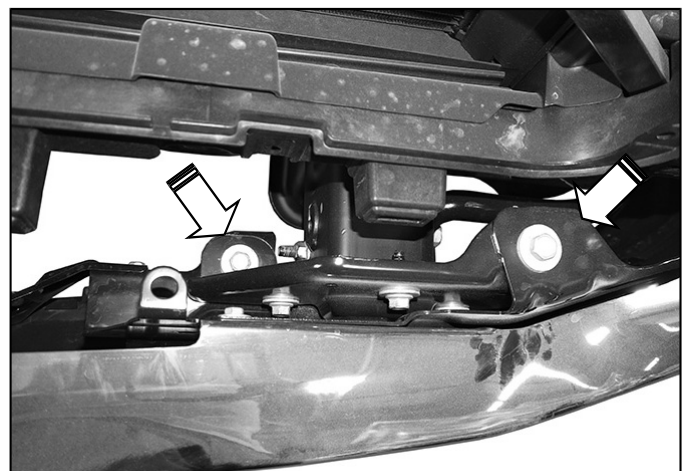

(Fig 4) Remove bumper bolts (pictured from above)

**WARNING!** Do not crawl under bumper unless the bumper is properly supported on blocks or stands or the bumper may fall.

Driver/left Side Installation Pictured

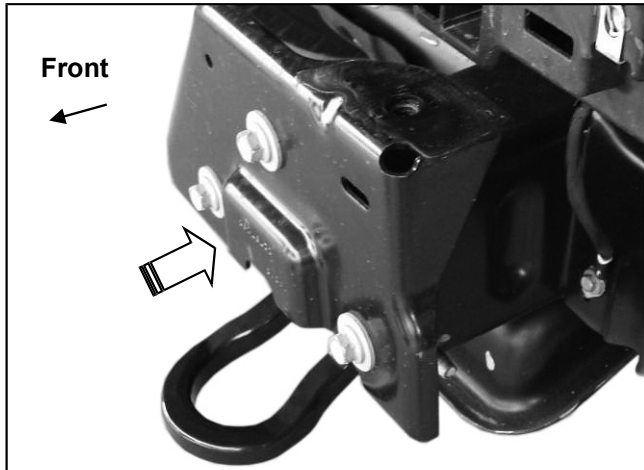

(Fig 5) Remove complete bumper and inner bumper bracket (arrow). Do not remove tow hook if equipped

**WARNING!** Do not crawl under bumper unless the bumper is properly supported on blocks or stands or the bumper may fall.

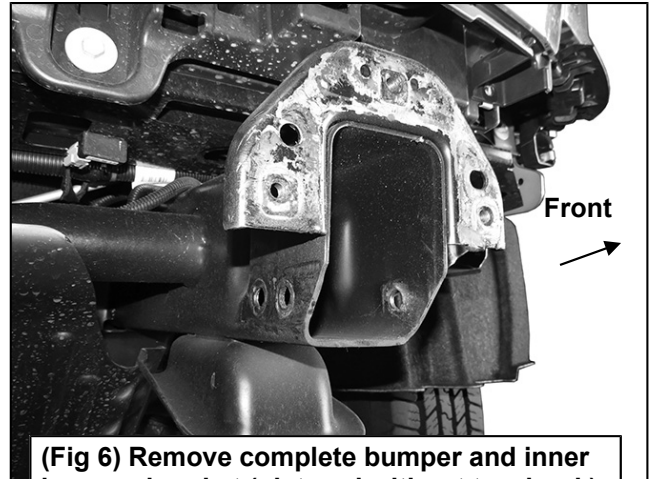

(Fig 6) Remove complete bumper and inner bumper bracket (pictured without tow hook)

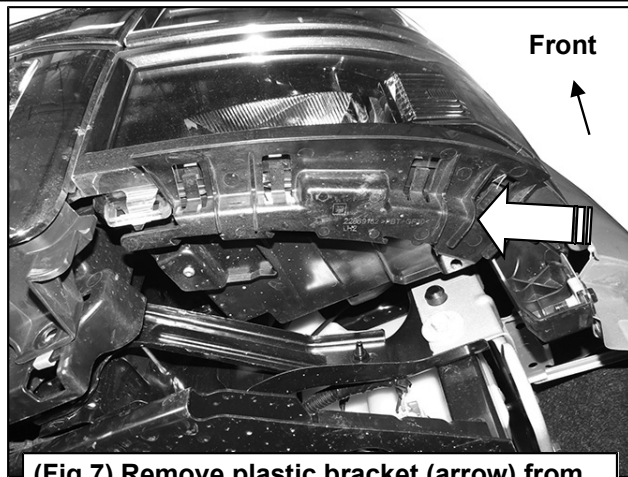

(Fig 7) Remove plastic bracket (arrow) from bottom of headlight (driver/left side pictured)

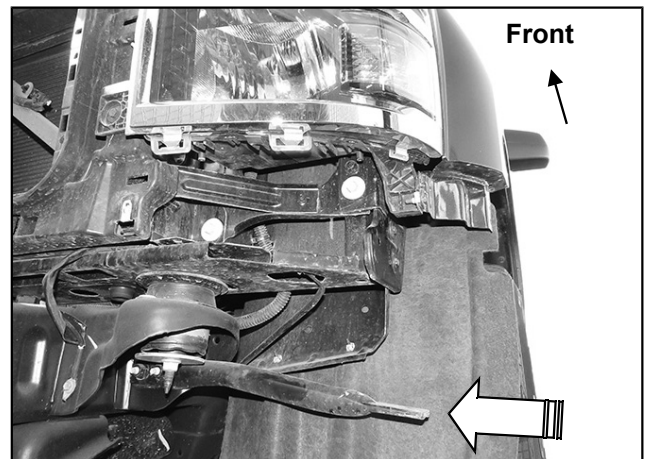

(Fig 8) Remove outer bumper supports (arrow)

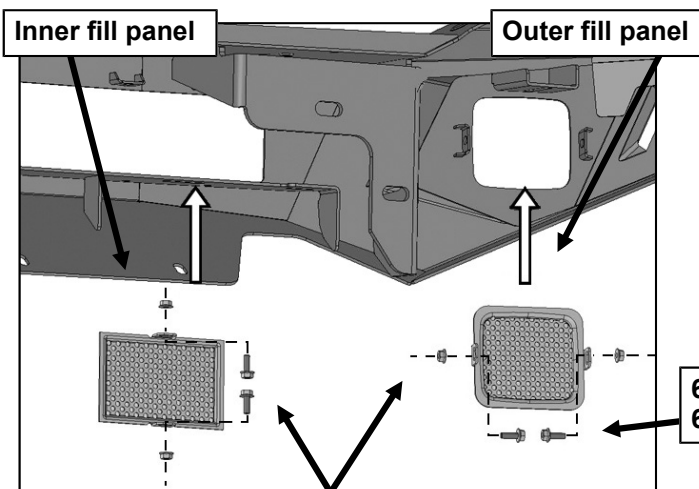

(Fig 9) Attach Mesh Fill Panels as desired to fill unused openings for lights (lights not included)

6mm Button Head Combo Bolts  
6mm Flange Hex Nuts

Driver/left Side Installation Pictured

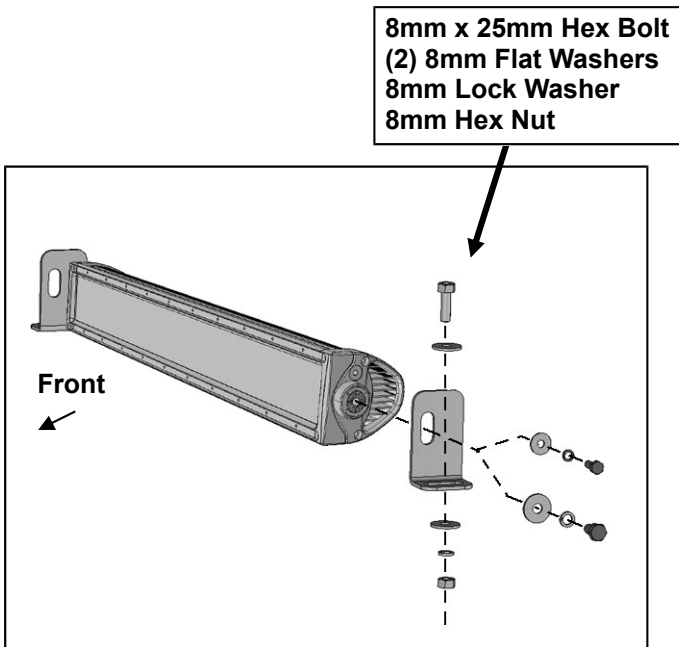
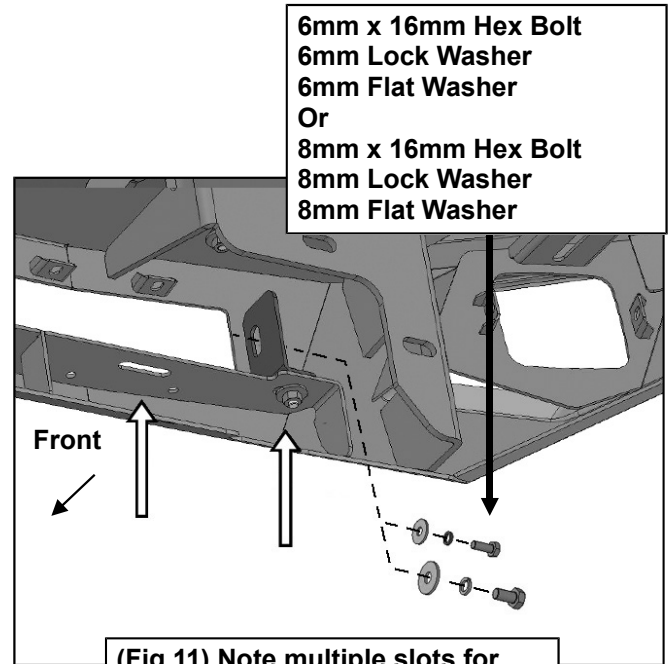
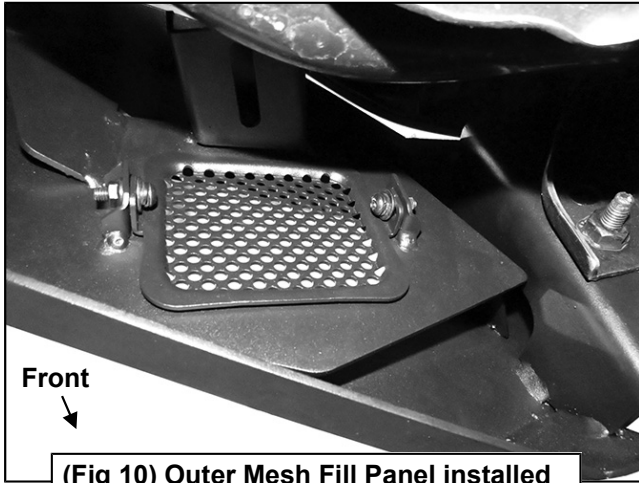

(Fig 12) Bracket illustration is a suggestion only. Brackets are offset to allow adjustment for all widths of lights

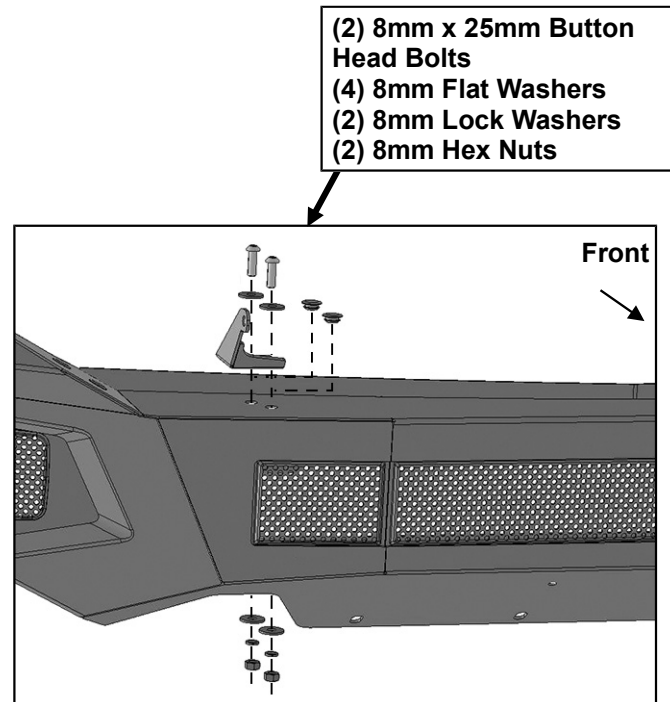

(Fig 13) Remove rubber plugs to attach Top Light Bracket to Bumper

Driver/left Side Installation Pictured

Top Light bracket mounting location is designed for light assembly 31.65" (804mm) to 32.44" (824mm)

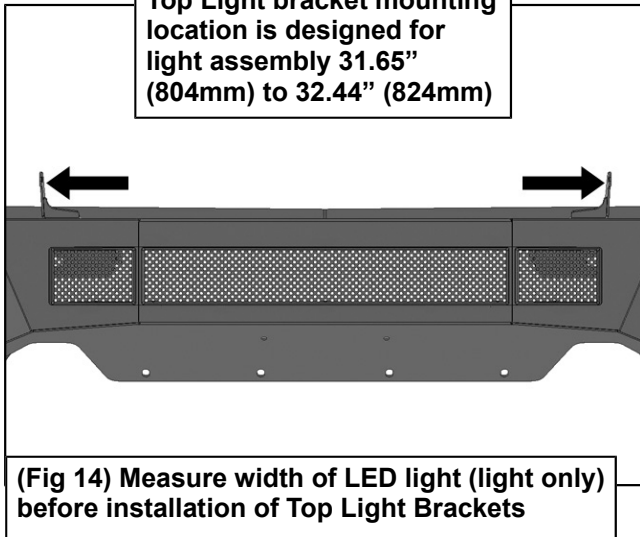

**WARNING!** Do not crawl under bumper unless the bumper is properly supported on blocks or stands or the bumper may fall.

