

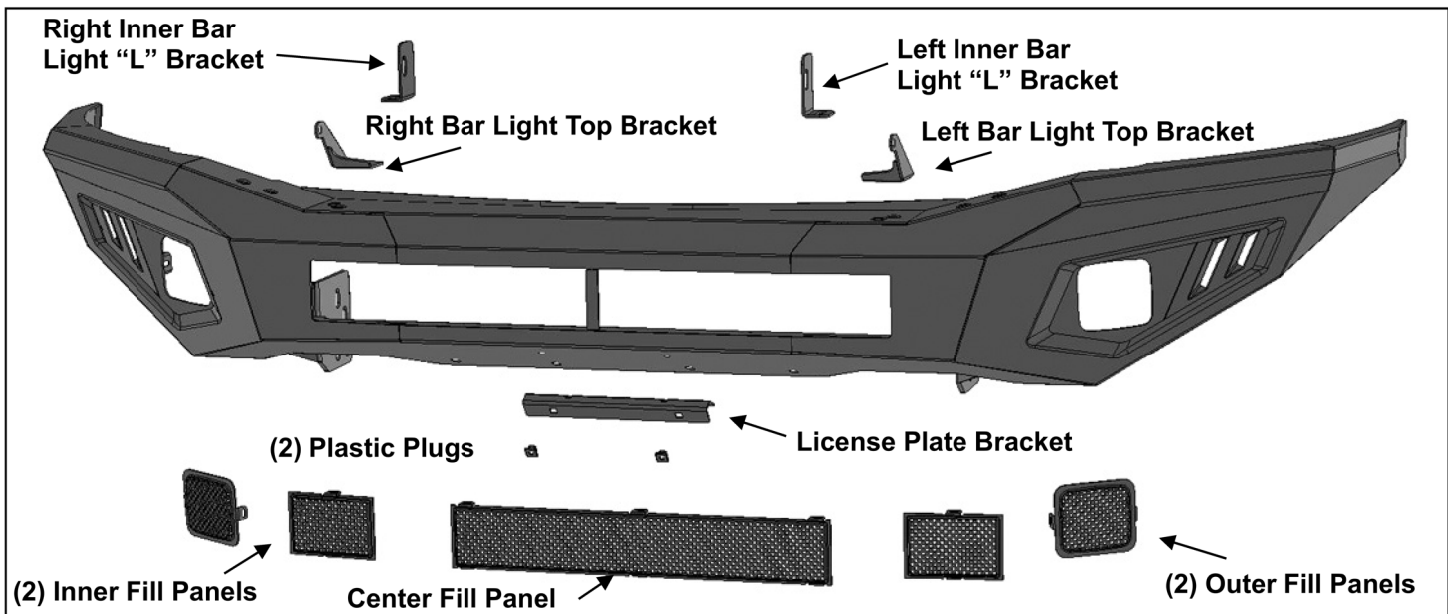

PARTS LIST: X3B-CSIL30-FB

1	LD2 Front Bumper Assembly	2	8mm x 25mm Hex Bolts
1	Long Mesh Plate	2	8mm x 16mm Hex Bolts
2	Short Mesh Plates	14	8mm x 24mm x 2mm Flat Washers
2	LED Cube corner mesh plates	8	8mm Lock Washer
1	Driver/left Top Light Bracket	6	8mm Hex Nut
1	Passenger/right Top Light Bracket	14	6-1.00mm x 20mm Combo Button Head Bolts
1	Driver/left "L" Bracket (center LED light)	2	6mm x 20mm Button Head Bolts
1	Passenger/right "L" Bracket (center LED light)	2	6-1.00mm x 16mm Hex Bolts
1	License Plate Bracket	6	6mm x 18mm x 1.6 Flat Washers
2	Plastic Plugs for License Plate	2	6mm Lock Washer
2	12mm x 140mm Hex Bolts	14	6-1.00mm Flange Hex Nuts
4	12mm x 32mm OD x 3mm Flat Washers	2	6mm Nylon Lock Nuts
2	12mm Lock Washers	1	5mm Wrench
2	12mm Hex Nuts	1	4mm Wrench
4	8-1.25mm x 25mm Button Head Bolts	10	Nylon Wire Ties



PROCEDURE:

REMOVE CONTENTS FROM BOX. VERIFY ALL PARTS ARE PRESENT. READ INSTRUCTIONS CAREFULLY BEFORE STARTING INSTALLATION. ASSISTANCE IS HIGHLY RECOMMENDED TO AVOID POSSIBLE INJURY OR DAMAGE TO THE VEHICLE.

1. Remove the license plate and bracket. On models with factory fog lights, unplug the wiring harness leading to the lights and move the harness away from the bumper, **(Figure 1)**.
2. From behind the bumper, remove the bolts attaching the bumper supports to the outer ends of the bumper.
3. Place blocks or jack stands under the front bumper to support it during mounting bolt removal. Once the bumper has been safely supported, remove the (4) large factory hex nuts, (two per side), attaching the bumper assembly to the end of the frame, **(Figure 2)**. **WARNING!** Assistance is required to hold the bumper in place during bolt removal to prevent the bumper from falling. Remove the factory double bolt plates from the bumper brackets and carefully slide the bumper assembly with brackets off of the end of the frame and tow hooks, if equipped, **(Figure 3)**.

**LD2 FRONT BUMPER
2007-13 CHEVY SILVERADO 1500**

4. Temporarily remove both tow hooks, (if equipped), from the ends of the frame, **(Figure 3)**.
5. Carefully unwrap the Bumper assembly. Determine if accessory lights, (not included), or Screen Fill Panels will be installed at this time. **IMPORTANT:** It may be easier to install Center Fill Panels and/or lights before installing Bumper.

Screen Fill Panel Installation (do not install fill panels if installing lights).

- a. Select desired Screen Fill Panels. **NOTE:** Outer Panels are square with rounded corners, Inner panels are rectangular with sharp corners, **(Figure 4)**.
- b. Attach Screen Fill Panels as needed with the included 6mm Button Head Combo Bolts and 6mm Flange Nuts, **(Figure 4)**. Fully tighten Fill Panel hardware at this time. Repeat to install all Panels as desired.

Inner center LED bar style light installation (light not included).

- a. Select the driver/left "L" Light Bar Bracket. **NOTE:** "L" Brackets are offset to adjust for different widths of LED Bar Lights and can be installed on either side as needed.
- b. Attach the L Bracket to the slot on the back of the Bumper with (1) 8mm x 25mm Hex Bolt, (2) 8mm Flat Washers, (1) 8mm Lock Washer and (1) 8mm Hex Nut, **(Figure 5)**. Repeat this Step to install the remaining "L" Bracket on the other side of the Bumper. **IMPORTANT:** The Bumper features slots designed for 20" and 30" bar style lights. Attach the Brackets to the correct slots in the Bumper. If necessary, hold the light up to the slots to help determine correct slots to use and combination of Brackets.
- c. Attach the light to the "L" Brackets with the hardware included with the light or the supplied (2) 8mm x 16mm Hex Bolts, (2) 8mm Lock Washers and (2) 8mm Flat Washers or (2) 6mm x 16mm Hex Bolts, (2) 6mm Lock Washers and (2) 6mm Flat Washers, **(Figures 5 & 6)**. Do not fully tighten hardware at this time.

Top mounted 30" bar style LED light (not included).

- a. Remove the (2) rubber plugs from the driver/left side mounting holes, **(Figure 7)**.
- b. Select the driver/left Light Bracket. Attach the Bracket to the top of the Bumper with (2) 8mm x 25mm Button Head Bolts, (4) 8mm Flat Washers, (2) 8mm Lock Washers and (2) 8mm Hex Nuts, **(Figure 7)**. Do not tighten hardware at this time.
- c. Repeat previous Steps to attach the passenger/right Bracket.
- d. Select the 30" light, (not included). Attach light to Top Brackets with the hardware included with the light. Adjust the width of the Brackets to the light and fully tighten bracket hardware.
IMPORTANT: Top Light Brackets are designed to install 30" bar style LED lights with outside length dimensions of 31.653" (804mm) to 32.44" (824mm) only, **(Figure 8)**. Fully tighten top light hardware once adjusted.

Outer LED cube style light installation (light not included).

- a. Attach lights to mounting tabs on back of each end of the Bumper, **(Figure 10)**.
6. With assistance, position the Bumper Assembly up to and over the end of the frame. Temporarily support the weight of the Bumper. **WARNING:** To avoid possible injury or damage to the vehicle, do not proceed until the Bumper is fully and safely supported.
7. Line up the (2) upper holes in the driver side mounting plate on the back of the Bumper with the (2) slots in the frame. Reuse the factory double bolt plate and hex nuts to attach the Bumper to the frame, **(Figures 9 & 10)**. Do not fully tighten hardware at this time. Repeat this **Step** to attach the passenger side of the Bumper to the frame.

Models without tow hooks, skip to Step 8.

Models with tow hooks only:

- a. Insert the driver/left tow hook back into the frame. Attach the front of the tow hook with the included longer (1) 12mm x 140mm Hex Bolt, (2) 12mm Flat Washers, (1) 12mm Lock Washer and (1) 12mm Hex Nut, **(Figure 9)**. Repeat this Step to reinstall the passenger/right tow hook.
IMPORTANT: On the passenger/right tow hook only, reuse the factory hex bolt to attach the rear mount on the tow hook. Do not fully tighten hardware at this time.
8. Level and adjust the bumper and fully tighten all hardware.
9. If front license plate is required, attach the License Plate Bracket to the holes in the bumper with the included (2) 6mm x 20mm Button Head Screws, (4) 6mm Flat Washers and (2) 6mm Nylon Lock Nuts.

**LD2 FRONT BUMPER
2007-13 CHEVY SILVERADO 1500**

Insert (2) Plastic Plugs into the square holes in the Bracket. Reuse the factory screws to attach the license plate to the plastic plugs, **(Figure 11)**.

10. Do periodic inspections to the installation to make sure that all hardware is secure and tight.

To protect your investment, Do not use any type of polish or wax that may contain abrasives that could damage the finish. Mild soap may be used to clean the Front Bumper assembly.

Driver Side Installation Pictured

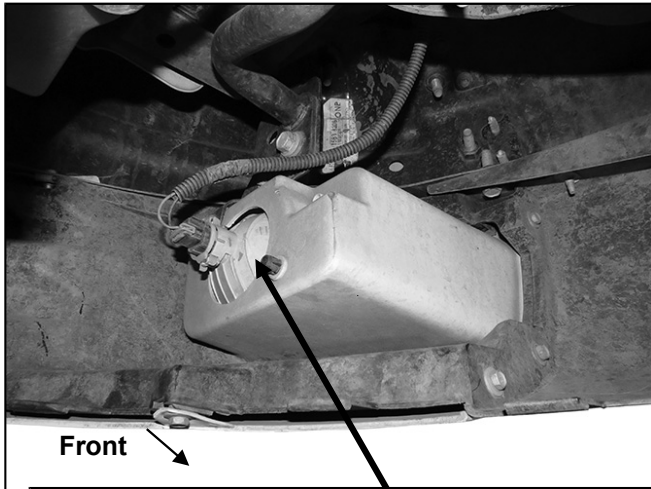

(Fig 1) Unplug fog lights and move wiring harness away from bumper before bumper removal

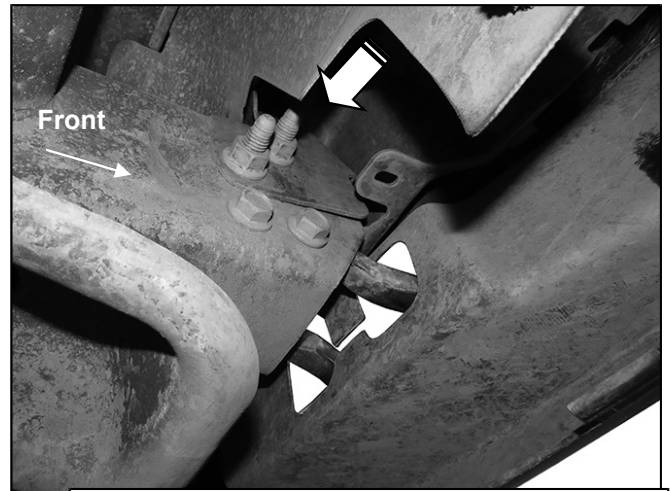

(Fig 2) From behind bumper, remove the hex nuts, (see arrow), and double bolt plates attaching the bumper bracket to the frame. Also temporarily remove the tow hooks if equipped, (Passenger/right side pictured)

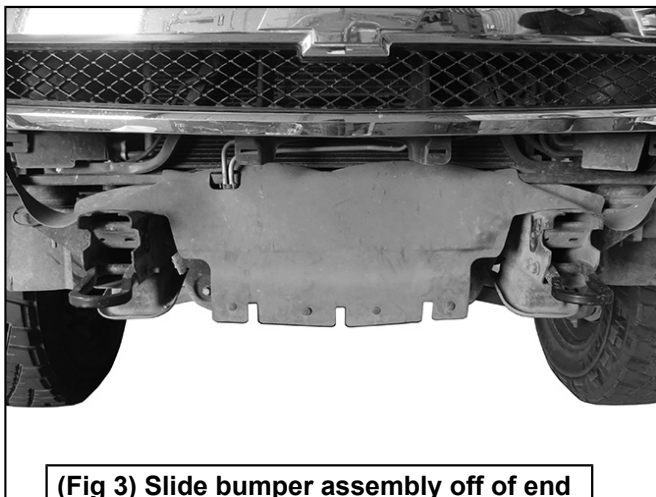

(Fig 3) Slide bumper assembly off of end of frame. Remove tow hooks if equipped

**6mm Button Head Combo Bolts
6mm Flange Hex Nuts**

WARNING! Do not crawl under bumper unless the bumper is properly supported on blocks or stands or the bumper may fall.

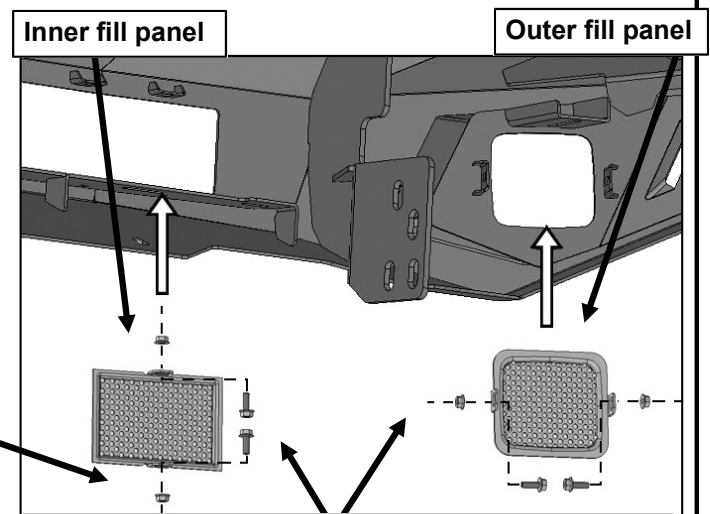

(Fig 4) Attach Mesh Fill Panels as desired to fill unused openings for lights (lights not included)

Driver Side Installation Pictured

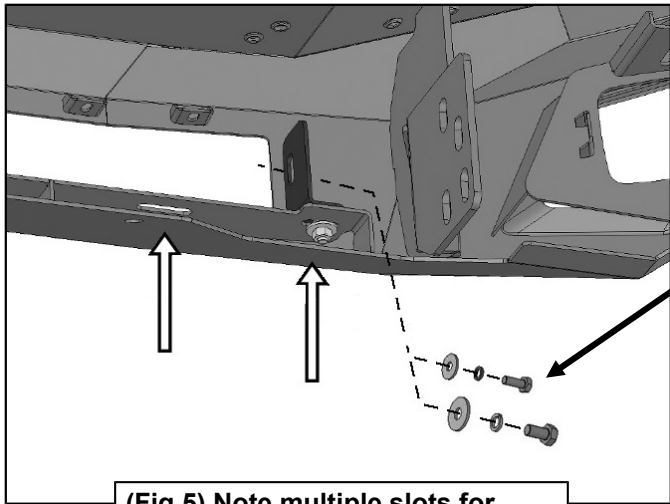

(Fig 5) Note multiple slots for different widths of lights (arrows)

- 6mm x 16mm Hex Bolt
- 6mm Lock Washer
- 6mm Flat Washer
- Or
- 8mm x 16mm Hex Bolt
- 8mm Lock Washer
- 8mm Flat Washer

- 8mm x 25mm Hex Bolt
- (2) 8mm Flat Washers
- 8mm Lock Washer
- 8mm Hex Nut

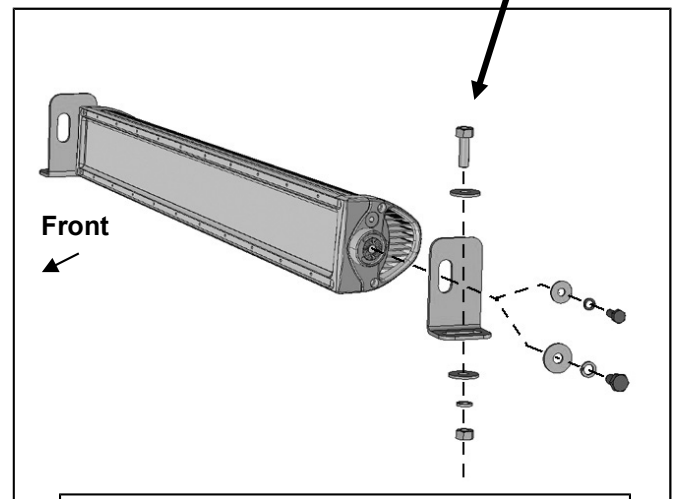

(Fig 6) Bracket illustration is a suggestion only. Brackets are offset to allow adjustment for all widths of lights

- (2) 8mm x 25mm Button Head Bolts
- (4) 8mm Flat Washers
- (2) 8mm Lock Washers
- (2) 8mm Hex Nuts

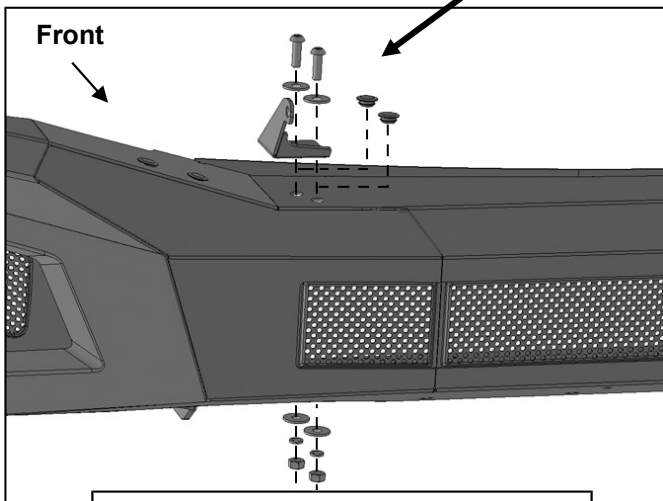

(Fig 7) Remove rubber plugs to attach Top Light Bracket to Bumper

Top Light bracket mounting location is designed for light assembly 31.65" (804mm) to 32.44" (824mm)

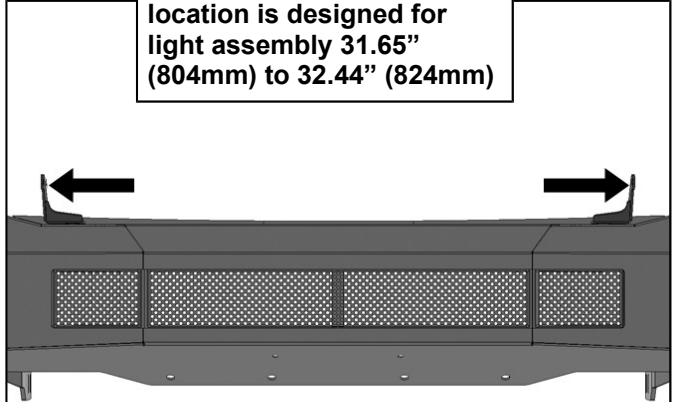

(Fig 8) Measure width of LED light (light only) before installation of Top Light Brackets

**LD2 FRONT BUMPER
2007-13 CHEVY SILVERADO 1500**

Driver Side Installation Picture

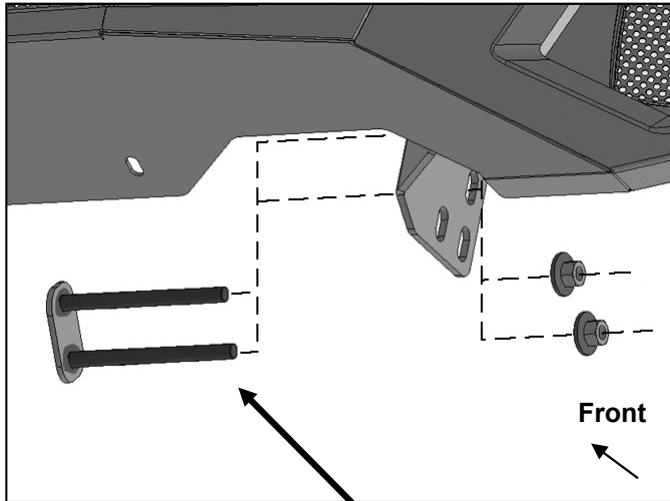

(Fig 9) Reuse factory double bolt plate to attach Bumper to end of Frame. Driver/left side illustrated

WARNING! Do not crawl under bumper unless the bumper is properly supported on blocks or stands or the bumper may fall.

**12mm x 140mm Hex Bolt
(2) 12mm Flat Washers
12mm Lock Washer
12mm Hex Nut**

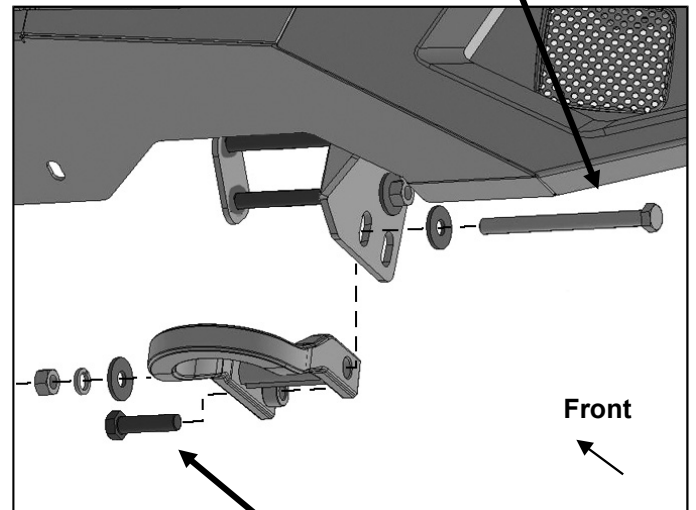

(Fig 10) Reuse short factory hex bolt to attach rear of tow hook to frame.

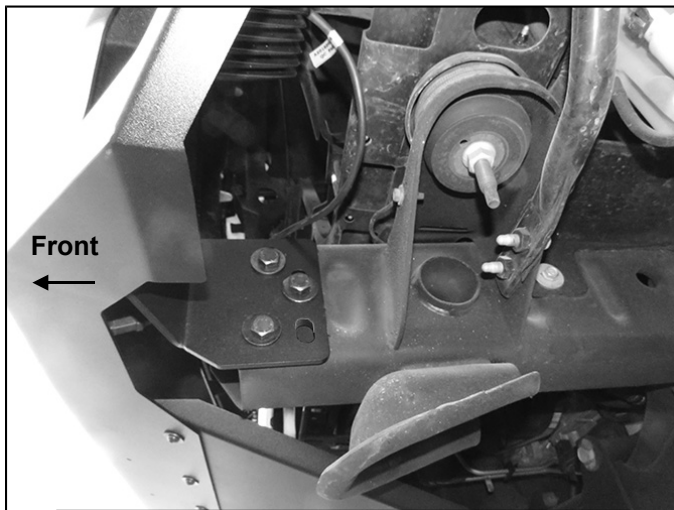

(Fig 11) Driver/left side of Bumper installed

**(2) 6mm x 20mm Button
Head Screws
(4) 6mm Flat Washers
(2) 6mm Nylon Lock Nuts**

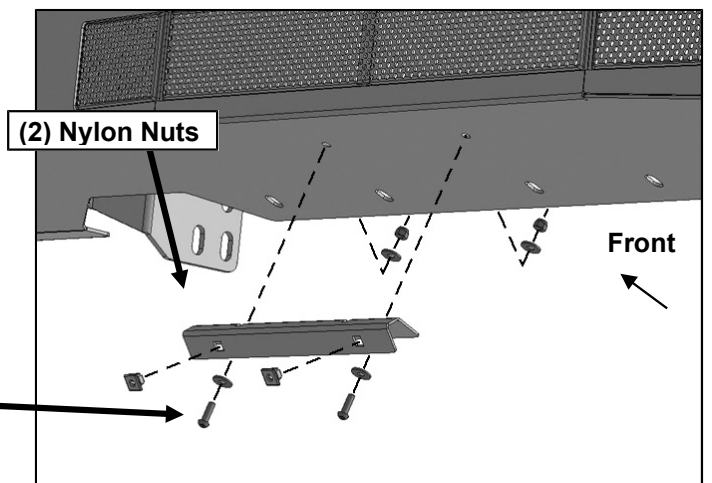

(Fig 12) Attach License Plate Bracket to Bumper