

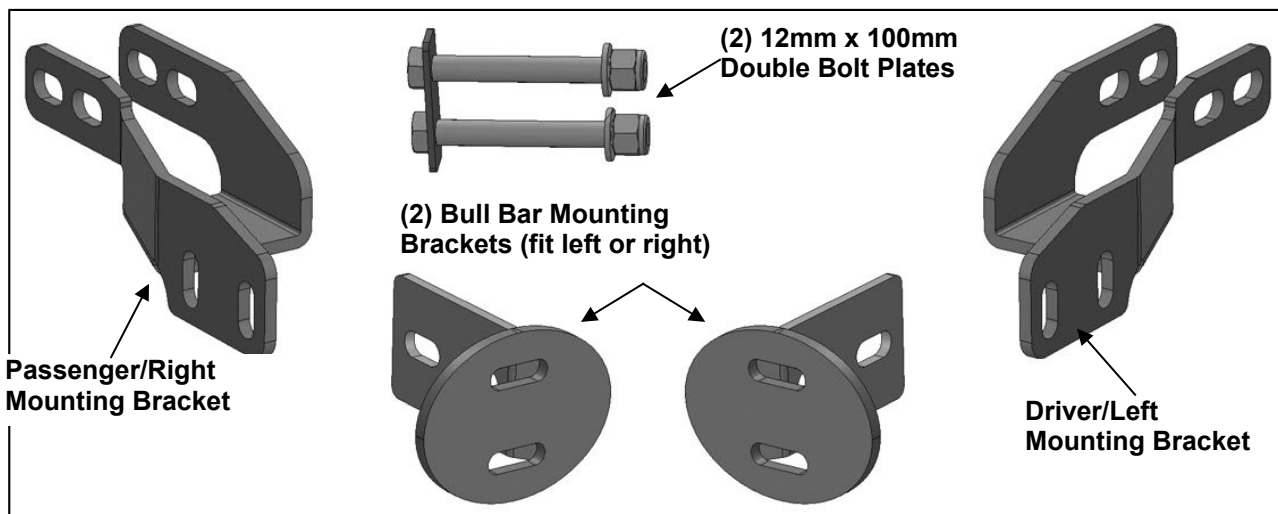

**PARTS LIST:**

Qty	Description	Qty	Description
1	3.5in Oval Bull Bar Assembly	4	10-1.5mm x 30mm Hex Bolts
1	Driver/left Mounting Bracket	8	10mm x 20mm OD x 2mm Flat Washers
1	Passenger/right Mounting Bracket	4	10mm Lock Washers
2	Bull Bar Mounting Brackets	4	10-1.5mm Hex Nuts
2	12-1.75mm x 100mm Double Bole Plates	4	8-1.25mm x 35mm Hex Bolts
4	12mm x 24mm OD x 2.5mm Flat Washers	6	8mm x 24mm x 2mm Flat Washers
4	12-1.75mm Nylon Lock Nuts	6	8mm Lock Washers
2	8-1.25mm x 16mm Hex Bolt		



**PROCEDURE:**

**REMOVE CONTENTS FROM BOX AND VERIFY ALL PARTS ARE PRESENT. READ INSTRUCTIONS CAREFULLY. CUTTING MAY BE REQUIRED. INSTALLATION MAY INTERFERE WITH FRONT MOUNTED SENSORS. NOTE:** It may be necessary to remove/relocate front license plate and license plate bracket. It is not required, but strongly recommended. If local/state law requires a front license plate, license plate relocation kit is available.

1. Start installation from under the front of the vehicle. Remove the plastic splash guard from below-behind bumper, **(Figure 1)**. Determine if the vehicle is equipped with tow hooks. **IMPORTANT:** Tow hooks cannot be reinstalled with the Bull Bar. Also, it may be necessary to temporarily remove the factory skid plate, (if equipped), to access the mounting locations.

**Tow Hook equipped vehicles:**

- a. Remove the driver side tow hook and hardware from the end of the frame channel, **(Figures 2 & 3)**. Remove the seal between the opening in the bumper and the tow hook, **(Figures 2 & 4)**.
- b. Repeat to remove the passenger side tow hook.
- c. Proceed to **Step 2**.

**Vehicles without tow hooks:**

- a. Cut out the indented area in both sides of the plastic bumper to clear the Brackets as pictured, **(Figures 5 & 6)**. **IMPORTANT:** Make several small cuts for best fit. **OPTION:** Cut around the Bracket as indicated, **(Figure 6)**, or cut along the rectangular cut line molded into the pocket, **(Figure 4)**.

2. Select the driver side Mounting Bracket, **(Figure 8)**. Insert the Bracket through the opening in the bumper and up to the tow hook mounting holes, **(Figures 7 & 9)**. Trim the plastic as required for clearance.

3. Line up the (2) holes in the Bracket with the (2) holes in the frame for the tow hook, **(Figure 7)**. Select the 12mm Double Bolt Plate, **(Figure 8)**. Insert the Bolt Plate through the Bracket and the (2) holes through the frame, **(Figures 7 & 9)**. Secure with (2) 12mm Flat Washers and (2) 12mm Nylon Lock Nuts. Do not fully tighten hardware at this time.
4. Repeat **Steps 2 & 3** to install the passenger side Mounting Bracket.
5. Next, select (1) Bull Bar Bracket, **(Figure 10)**. Attach the Bracket to the end of the Bull Bar with (2) 8mm Hex Bolts, (2) 8mm Lock washers and (2) 8mm Flat Washers, **(Figure 11)**. Do not fully tighten hardware at this time. Repeat to attach the remaining Bull Bar Bracket to the passenger/right side.
6. With assistance, hold the Bull Bar with Brackets up in position on the inside of the Mounting Brackets. Attach the Bull Bar to the Brackets with (4) 10mm x 30mm Hex Bolts, (8) 10mm Flat Washers and (4) 10mm Nylon Lock Nuts, **(Figure 12)**. Do not tighten hardware at this time.
7. Check the Bull Bar alignment with the vehicle and for clearance between the Bull Bar and the bumper. Adjust as required then fully tighten all hardware.
8. Reinstall the plastic splash guard or skid plate removed in **Step 1, (Figure 1)**.
9. Do periodic inspections to the installation to make sure that all hardware is secure and tight.

**To protect your investment**, wax this product after installing. Regular waxing is recommended to add a protective layer over the finish. Do not use any type of polish or wax that may contain abrasives that could damage the finish.

**For stainless steel:** Aluminum polish may be used to polish small scratches and scuffs on the finish. Mild soap may be used also to clean the Bull Bar.

**For gloss black finishes:** Mild soap may be used to clean the Bull Bar.

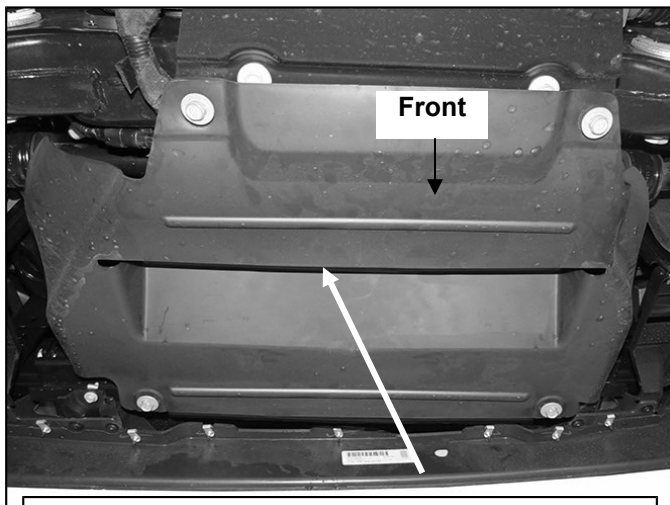

**(Fig 1) Remove splash guard or skid plate from bottom of engine behind bumper if necessary**



**(Fig 2) Passenger side with tow hook**

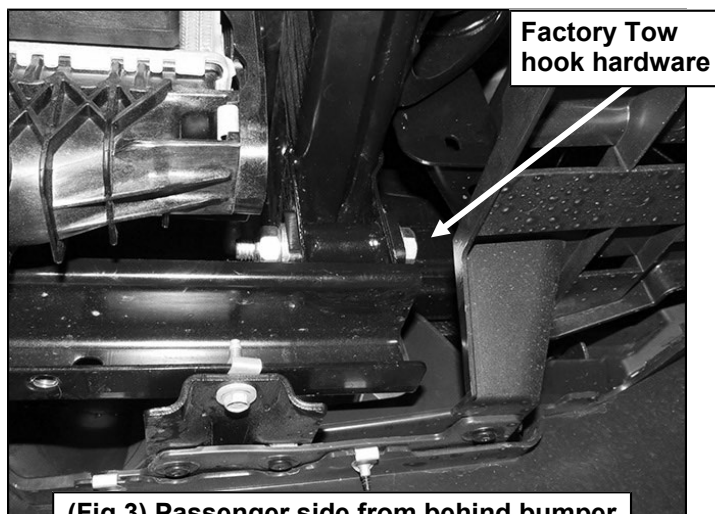

**(Fig 3) Passenger side from behind bumper**



**(Fig 4) Driver side after tow hook removed**

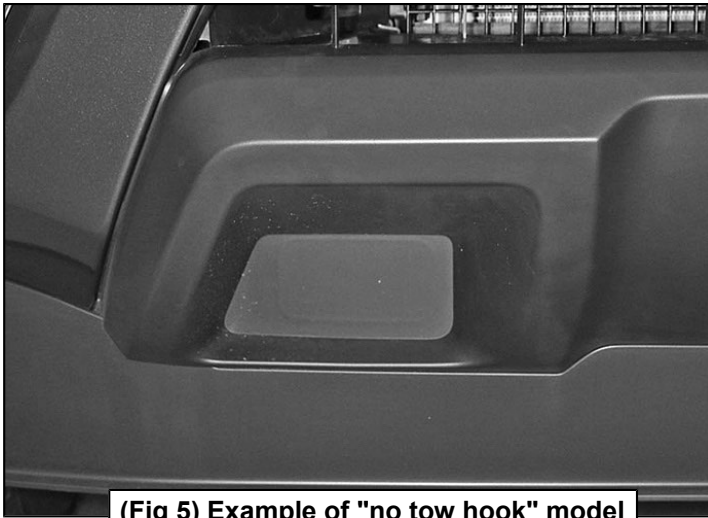

(Fig 5) Example of "no tow hook" model

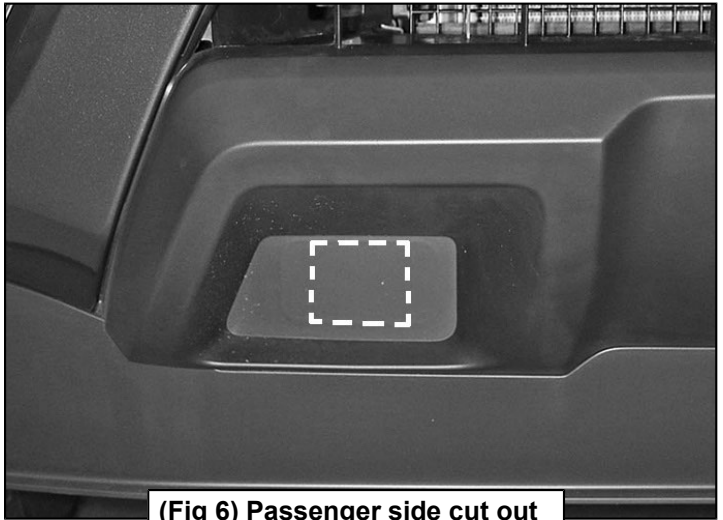

(Fig 6) Passenger side cut out illustrated for reference only

Mounting holes in end of frame for tow hook

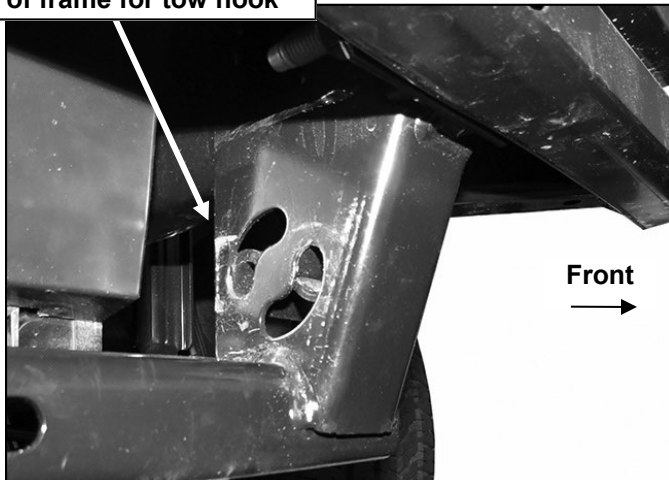

(Fig 7) Driver side pictured without bumper for instruction purposes only. Do not remove bumper

12mm Double Bolt Plate  
(4) 12mm Flat Washers  
(2) 12mm Nylon Lock Nuts

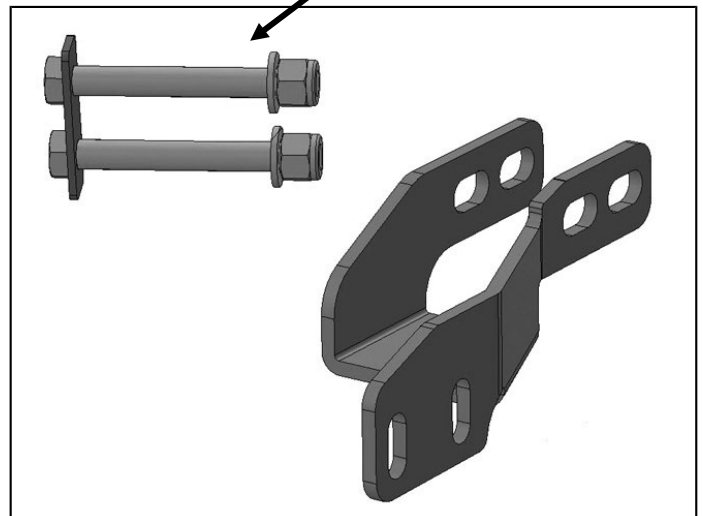

(Fig 8) Driver/left Mounting Bracket and 12mm Double Bolt Plate

- 12mm Double Bolt Plate
- (4) 12mm Flat Washers
- (2) 12mm Nylon Lock Nuts

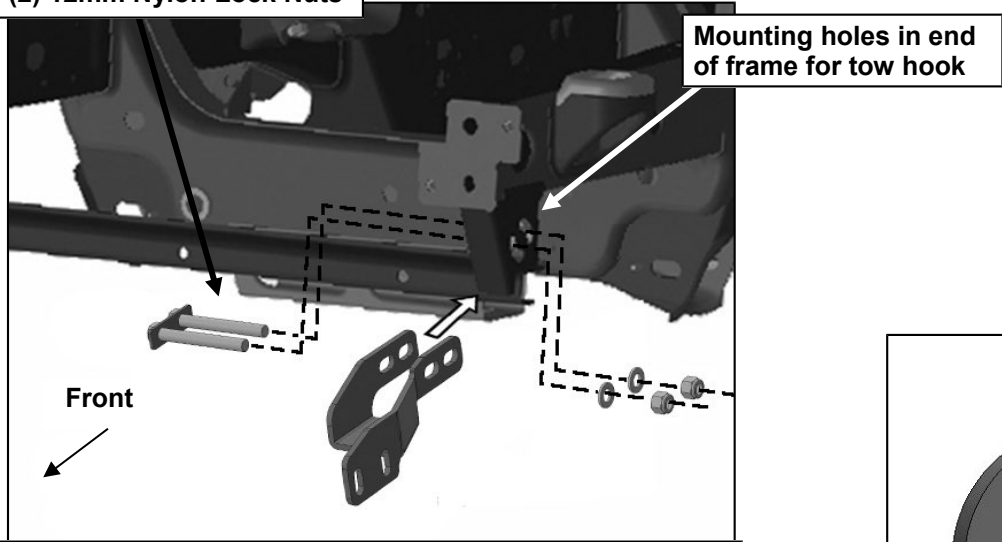

(Fig 9) Installation illustrated without bumper cover for instruction purposes only. Do not remove bumper cover.

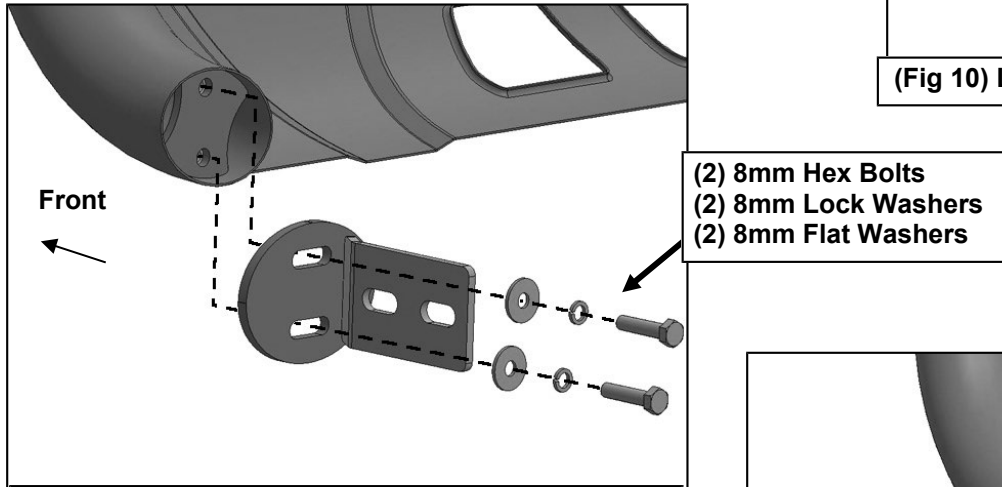
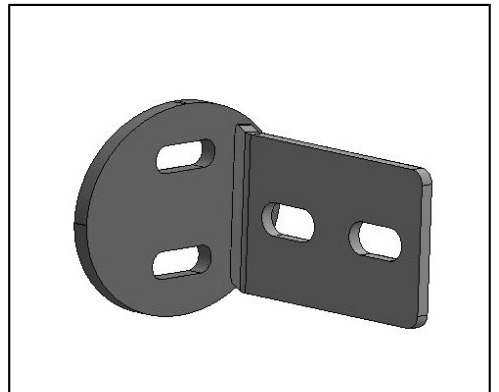

(Fig 11) Attach Bull Bar Bracket to end of Bull Bar

- (2) 10mm Hex Bolts
- (4) 10mm Flat Washers
- (2) 10mm Lock Washers
- (2) 10mm Hex Nuts

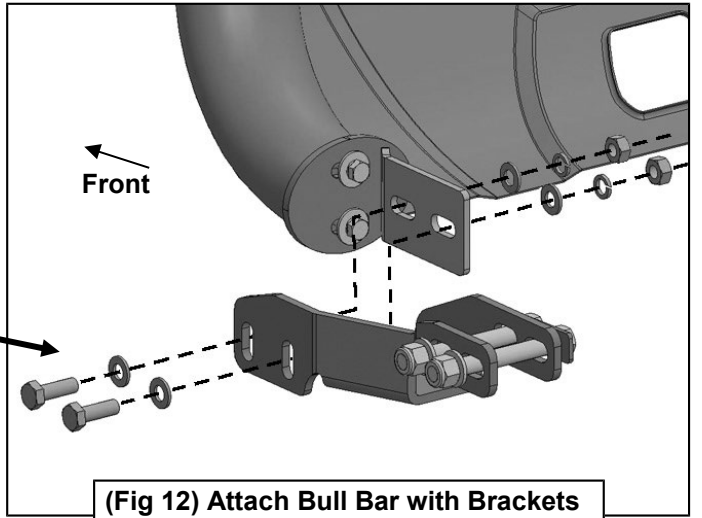

(Fig 12) Attach Bull Bar with Brackets to inside of Mounting Brackets

### PARTS LIST:

Qty	Description
1	Light
1	Wiring Harness

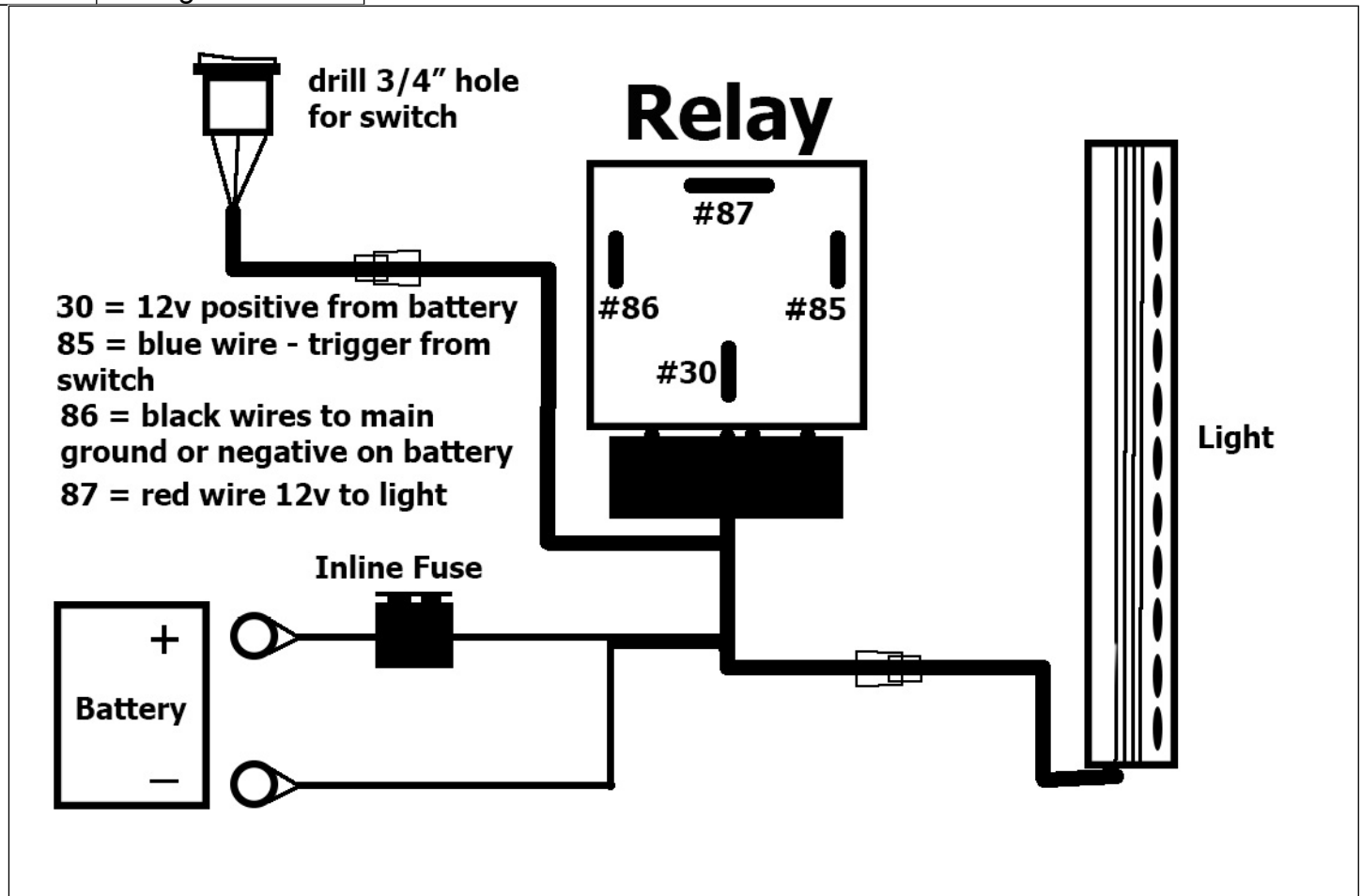

### PROCEDURE:

1. REMOVE CONTENTS FROM BOX. VERIFY ALL PARTS ARE PRESENT. READ INSTRUCTIONS CAREFULLY. DRILLING IS REQUIRED. ELECTRICAL KNOWLEDGE IS HIGHLY RECOMMENDED.
2. Install Light into product as instructed. Open hood and disconnect battery.
3. Unwrap preassembled wiring harness. Disconnect the plug in the harness leading to the lighted switch. Locate suitable mounting location for switch. Drill 3/4" hole in panel to mount switch. **IMPORTANT:** Do not drill any holes in panel until back of location is properly checked for clearance. Use of safety goggles is required.
4. Run switch harness through firewall on vehicle. Drill hole through firewall as required for harness plug. Highly recommend use of rubber grommet (not included) to protect harness. Feed switch harness plug through hole in firewall. Seal firewall with silicone as necessary.
5. Attach Relay and main harness to suitable location near battery (firewall or inner fender for example). Do not connect to battery at this time.
6. Attach switch plug to switch harness and tie harness away from anything that could damage harness.
7. Run the prewired light harness down to the light. Plug harness into prewired plug on light. Tie wiring harness away from anything that could damage harness.
8. Attach the fused red positive and black negative wires on the main harness to the battery. **NOTE:** Attach black negative wire to negative terminal on battery or suitable chassis ground.
9. Reattach battery cables to battery. Installation is complete.
10. Do periodic inspections to the installation to make sure that all hardware is secure.