

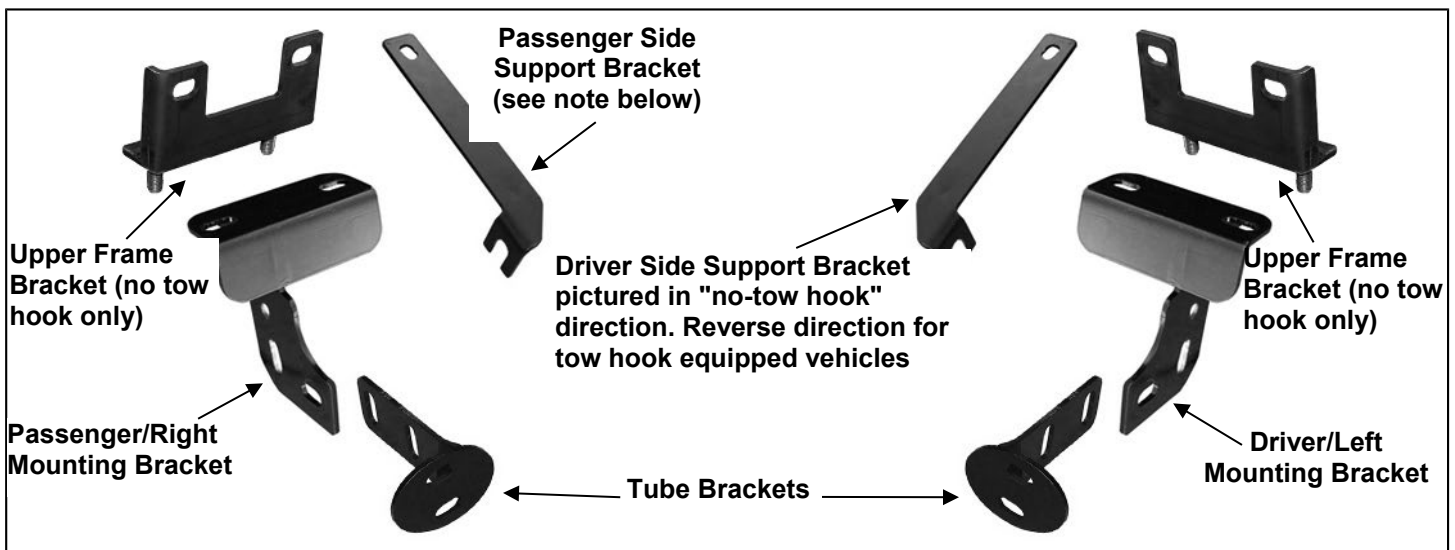

PARTS LIST:

1	Bull Bar	2	10-1.5mm x 35mm Hex Bolts
2	Tube Brackets (Bull Bar) passenger or driver side	2	10mm Lock Washers
1	Driver/Left Upper Bracket (models w/o tow hooks only)	4	10mm x 27mm OD x 3mm Flat Washers
1	Passenger/Right Upper Bracket (models w/o tow hooks only)	2	10-1.5mm Hex Nuts
1	Driver/Left Frame Mounting Bracket	4	8-1.25mm x 35mm Hex Bolts
1	Passenger/Right Frame Mounting Bracket	4	8mm x 22mm OD x 2mm Flat Washers
1	Driver/Left Support Bracket	6	8mm Lock Washers
1	Passenger/Right Support Bracket	2	5-.8mm x 20mm Button Head Allen Bolt
2	12-1.5mm x 30mm Special Fine Thread Hex Bolt (for models w/o tow hooks only)	4	5mm x 10mm OD x 1mm Flat Washers
4	12-1.75mm x 35mm Hex Bolts	2	5mm Nylon Lock Nuts
14	12mm x 32mm OD x 3mm Flat Washers	1	Wrench (Allen bolt)
10	12mm Lock Washers	2	8mm x 24mm x 2mm Flat Washer
8	12-1.75mm Hex Nuts	2	8-1.25mm x 16mm Hex Bolt



PROCEDURE:

REMOVE CONTENTS FROM BOX. VERIFY ALL PARTS ARE PRESENT. READ INSTRUCTIONS CAREFULLY BEFORE STARTING INSTALLATION. CUTTING IS REQUIRED. ASSISTANCE IS RECOMMENDED. INSTALLATION MAY INTERFERE WITH FRONT BUMPER MOUNTED SENSORS. NOT RECOMMENDED FOR VEHICLES WITH "ACTIVE" LASER GUIDED CRUISE CONTROL SYSTEMS.

1. Start installation under the front bumper and carefully remove the plastic splash guard. **NOTE:** Depending on the model of truck, the splash guard may be attached to the bottom of the truck with hex bolts and several two-piece plastic push-in clips, **(Figure 1A)**. Remove all hex bolts then locate the clips behind the bumper cover. Pry up on the center pin of the clip with a small flat blade screwdriver and remove the entire clip, **(Figure 1B)**. Pay close attention to the type and location of all factory hardware for reinstallation. **IMPORTANT:** The splash guard may also be attached at the ends of the bumper cover with rivets. Use wire cutters to remove the rivets. Move the splash guard to a clean stable work area.

2. Next, determine if the truck is equipped with tow hooks.

For models without tow hooks:

- a. Remove the (2) hex nuts from the two lower bumper bolts, **(Figure 2)**.

- b. Select the driver/left Upper Bracket, (models w/o tow hooks only), and the driver/left Frame Bracket, **(Figure 3)**. Attach the Frame Bracket to the studs in the bottom of the Upper Bracket with (2) 12mm Flat Washers, (2) 12mm Lock Washers and (2) 12mm Hex Nuts, **(Figure 4)**. Do not tighten at this time.
- c. Reuse the factory hex nuts to attach the Bracket assembly to the bumper bolts. Do not fully tighten the hardware, **(Figure 7)**.

NOTE: On some vehicles, it may be easier to assemble the two-piece bracket on the vehicle. Install the Upper Bracket first, then attach the Frame Bracket to the bottom as previously described.

- d. Select the driver side Lower Support Bracket, **(Figure 5)**. Attach the bent end of the Support Bracket to the inside of the top hole in the Mounting Bracket with the included (1) 10mm x 35mm Hex Bolt, (2) 10mm Flat Washers, (1) 10mm Lock Washer and (1) 10mm Hex Nut, **(Figure 6)**.

NOTE: On models without tow hooks, Support Bracket can be installed in either direction, **(Figures 5, 6—9)**.

- e. Attach the inner end of the Support Bracket to the bottom of the frame with (1) 12-1.5mm x 30mm **Special Fine Thread** Hex Bolt, (1) 12mm Lock Washer and (1) 12mm Flat Washer, **(Figure 5)**.
IMPORTANT: The hole in the bottom of the frame is **fine thread**. Only use the 12-1.5mm x 30mm Fine Thread Hex Bolt provided in the hardware kit. Do not tighten all hardware at this time.

For models with tow hooks:

- a. Remove the (2) hex nuts attaching the front of the tow hook to the bottom of the bumper bracket, **(Figure 10)**.
 - b. Select the driver/left Frame Bracket, **(Figure 11)**. Attach the Bracket to the bottom of the tow hook with the (2) factory hex nuts. Do not tighten hardware at this time.
 - c. Loosen but do not remove the rear tow hook bolt, **(Figure 10)**. Slide the inner bent end of the driver side Support Bracket between the bolt and the tow hook or replace with the included (1) 12-1.5mm x 30mm **Special Fine Thread** Hex Bolt, (1) 12mm Lock Washer and (1) 12mm Flat Washer, **(Figure 12)**. Do not tighten hardware at this time.
 - d. Line up the flat forward end of the Support Bracket with the inside of the Mounting Bracket. The Support Bracket will attach to the lower rear hole in the Bracket. Do not attach at this time.
3. Repeat the appropriate **Step 2** for the passenger side Mounting Bracket installation.
 4. Next, select (1) Tube Mounting Bracket, **(Figure 13)**. Attach the Tube Bracket to the end of the Bull Bar with (2) 8mm x 35mm Hex Bolts, (2) 8mm Lock Washers and (2) 8mm Flat Washers. Leave hardware loose at this time. Repeat this **Step** to install the passenger side Tube Bracket.
 5. With assistance, position the Bull Bar with Tube Brackets up to the inside of the Frame Brackets. Use the included (4) 12-1.75mm x 35mm Hex Bolts, (8) 12mm Flat Washers, (4) 12mm Lock Washers and (4) 12mm Hex Nuts to attach the Tube Brackets to the Mounting Brackets, **(Figures 14)**. **NOTE:** On vehicles with tow hooks, insert the 12mm rear Hex Bolt through the rear hole in the Mounting Bracket, the Tube Bracket in the middle and out through the flat end of the Support Bracket. Do not tighten hardware at this time.
 6. Stand back from the vehicle and check to see that the Bull Bar is centered and level on the vehicle and adjust as necessary. Tighten only the hardware securing the Upper and Frame Mounting Brackets to the vehicle first. Next tighten only the (4) 8mm Hex Bolts securing the Tube Brackets to the Bull Bar as described in **Step 4**. Do not tighten the 12mm hardware attaching the Tube Brackets to the Frame Mounting Brackets. Remove the Bull Bar with Tube Brackets attached.
 7. Hold the splash guard up to the bumper cover and align it with the mounting points, **(Figure 15)**. Mark the location of the Mounting Brackets onto the back of the splash guard, **(Figures 15—17)**. Cut an approximately 1" wide by 4" long slot in the splash guard, **(Figure 17)**. **NOTE:** The size of the slot is an estimate only and may vary due to different factory designs for the splash guards and front bumper covers. Also, additional cutting may be required to clear the Support Bracket on vehicles equipped with tow hooks. **IMPORTANT:** To avoid weakening the splash guard, do not cut the slot any larger than necessary. Do not cut through the front or back edges of the cover, **(Figure 17)**. Make several small cuts first and check the fit often for a clean installation.
 8. Reinstall the splash guard using the factory hardware. Use the included (2) 5mm x 15mm Allen Bolts, (4) 5mm Flat Washers and (2) 5mm Lock Nuts at the ends of the splash guard if required, **(Figure 18)**.

9. Reinstall the Bull Bar described in **Step 5, (Figure 14)**.
10. Level and adjust the Bull Bar and tighten all hardware.
11. Do periodic inspections to the installation to make sure that all hardware is secure and tight.

To protect your investment, wax this product after installing. Regular waxing is recommended to add a protective layer over the finish. Do not use any type of polish or wax that may contain abrasives that could damage the finish.

For stainless steel: Aluminum polish may be used to polish small scratches and scuffs on the finish. Mild soap may be used also to clean the Bull Bar.

For gloss black finishes: Mild soap may be used to clean the Bull Bar.

Driver Side Installation Pictured

Pry up the center pin to remove the complete fastener

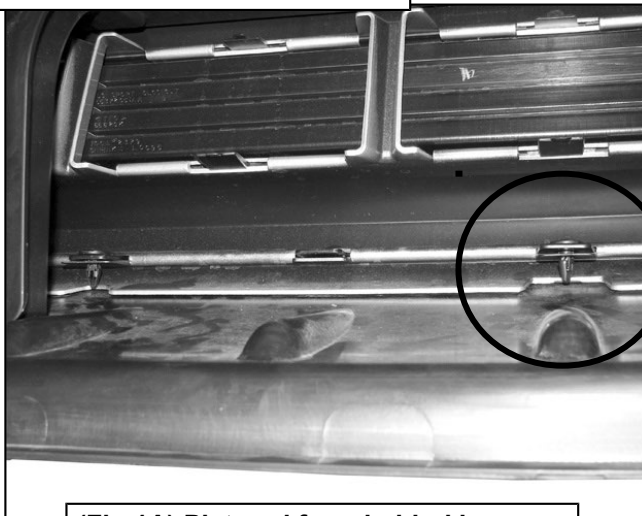

(Fig 1A) Pictured from behind bumper

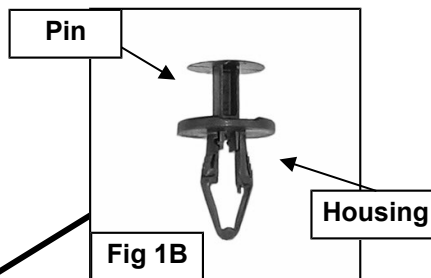

Remove the (2) factory hex nuts from the lower bumper bolts

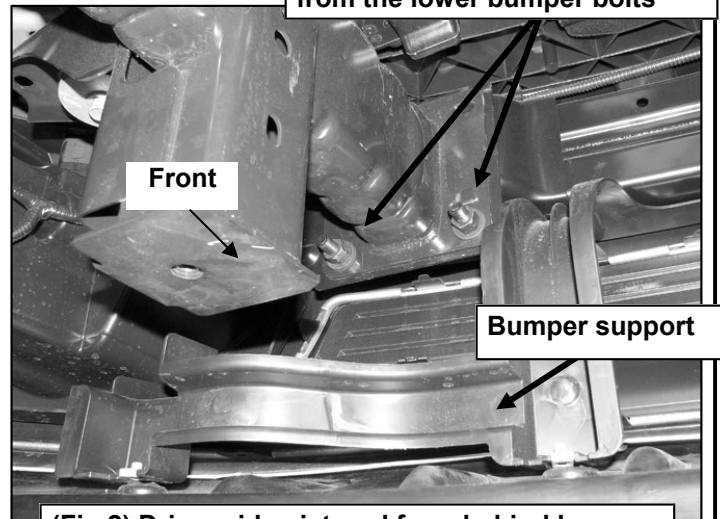

(Fig 2) Driver side pictured from behind bumper (model w/o tow hooks with bumper support)

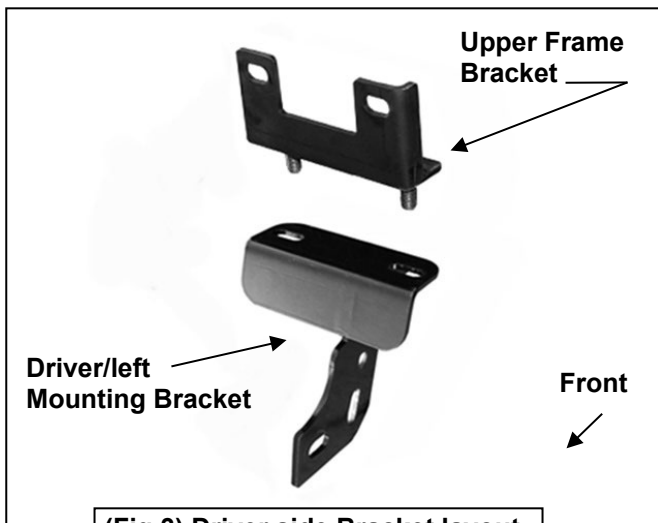

(Fig 3) Driver side Bracket layout in "w/o tow hook" position

Driver Side Installation Pictured

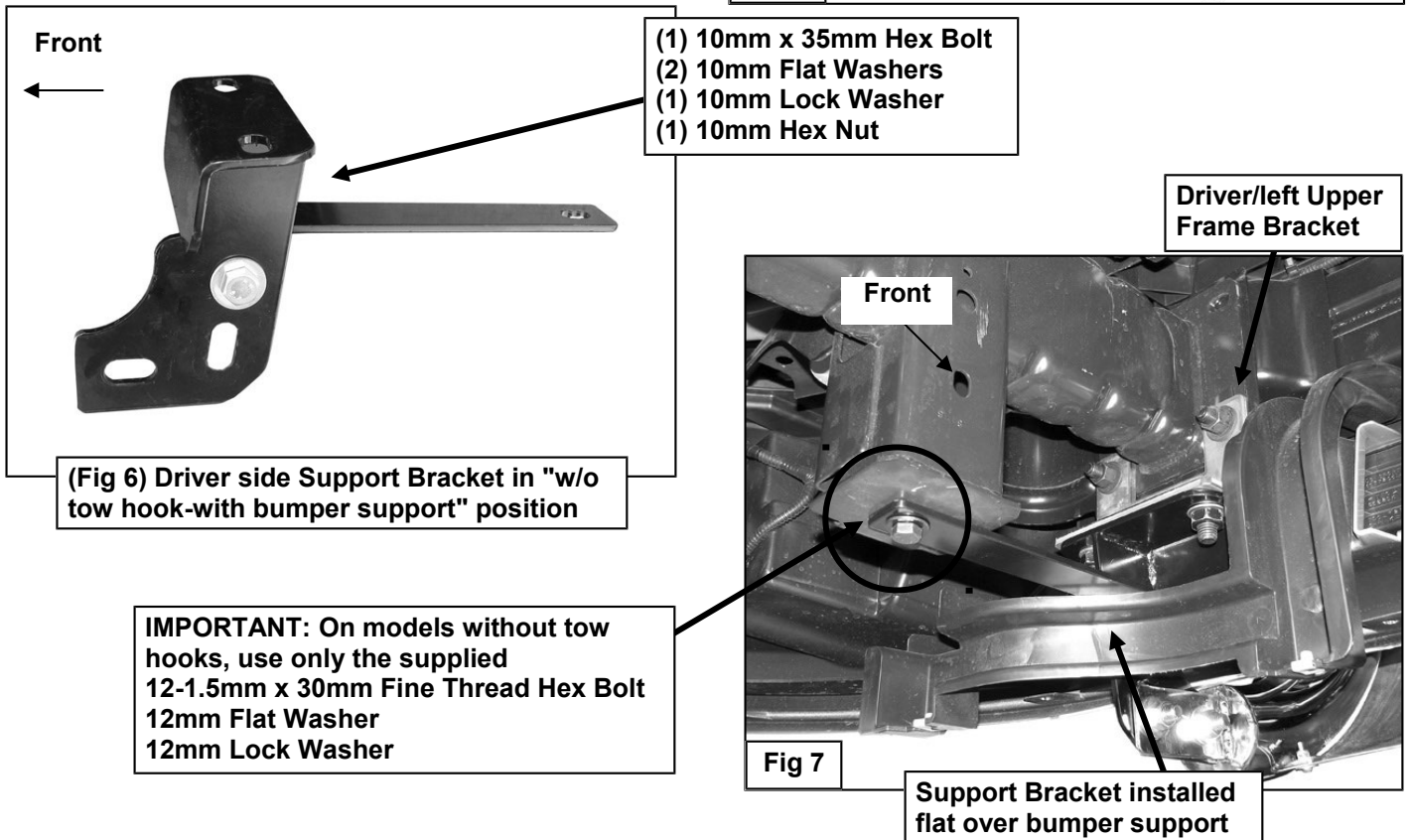
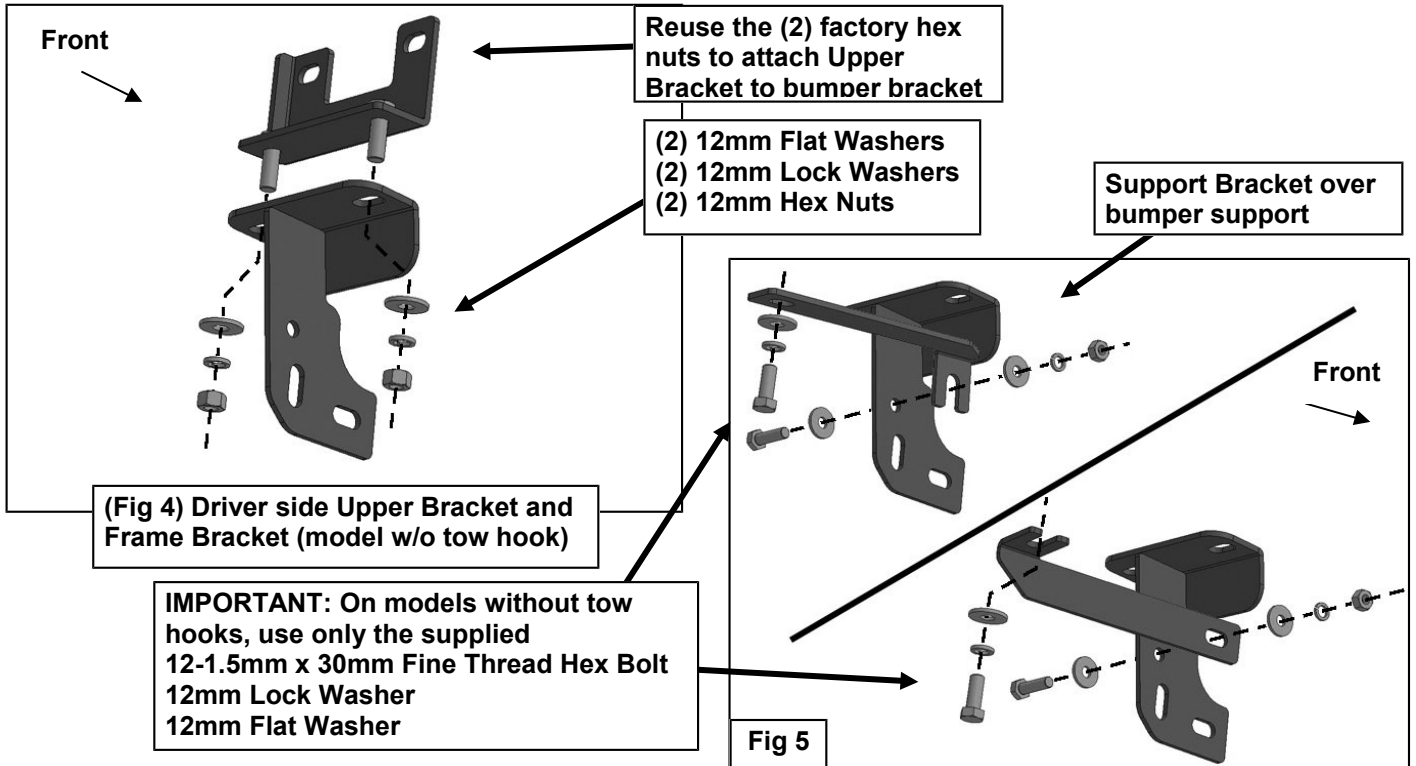

Driver Side Installation Pictured

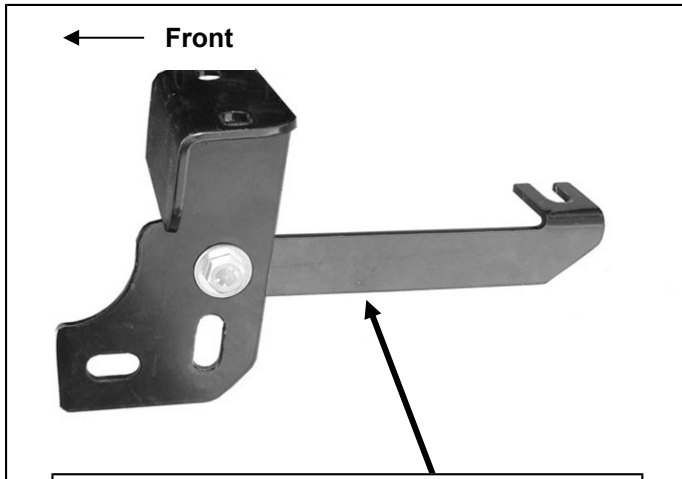

(Fig 8) Driver side Support Bracket in "w/o tow hook-w/o bumper support" position

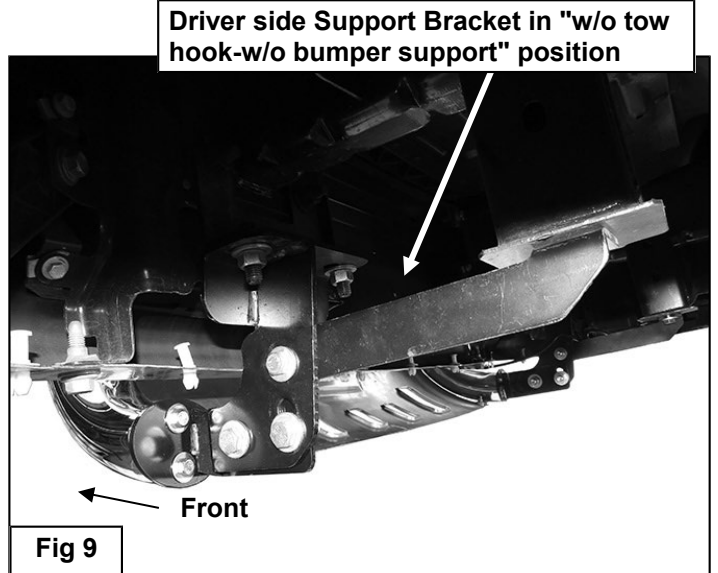
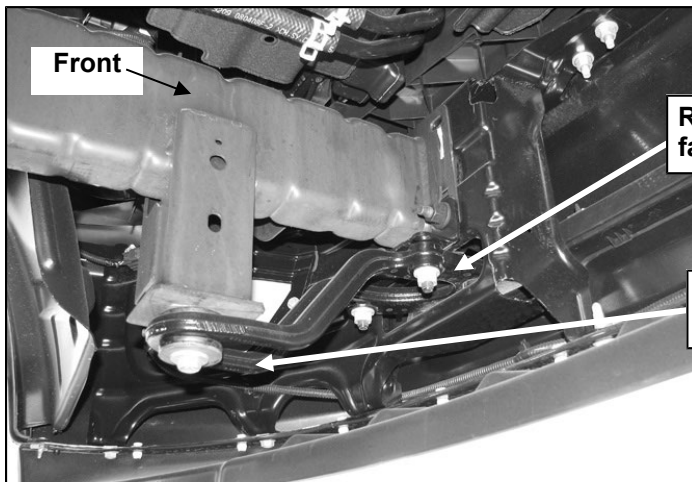

Fig 9



(Fig 10) Driver side mounting location pictured from behind bumper on tow hook equipped model

Remove the (2) factory hex nuts

Loosen but do not remove factory hex bolt attaching tow hook to frame

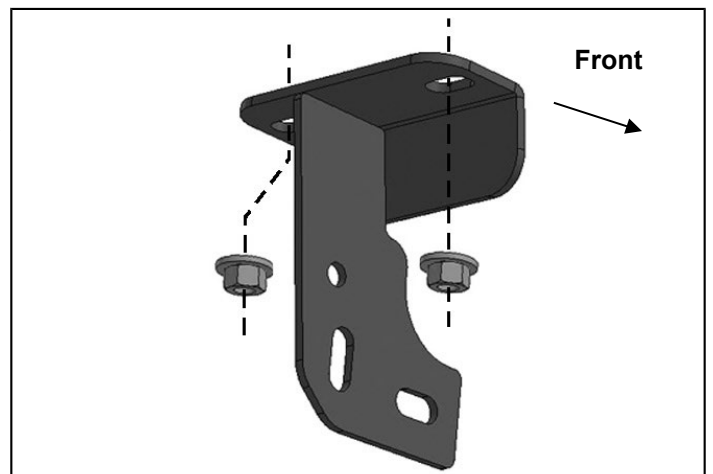

(Fig 11) Reuse factory hex nuts to attach driver/left Frame Bracket to bottom of tow hook

Driver Side Installation Pictured

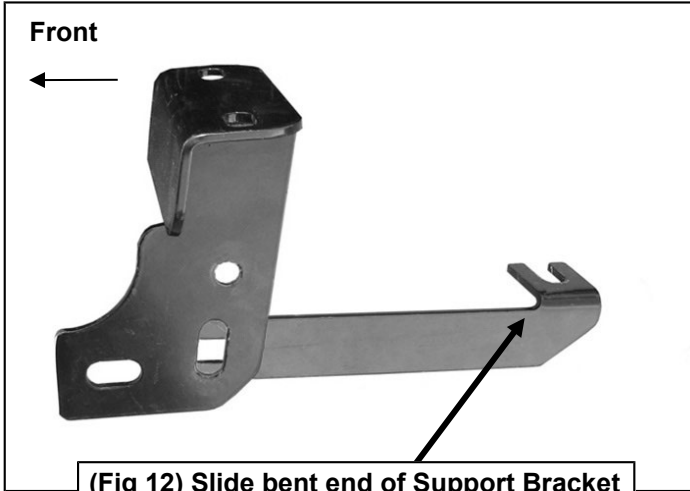

(Fig 12) Slide bent end of Support Bracket under head of factory hex bolt attaching tow hook to frame (Fig 10). Do not attach forward end of Support Bracket.

- (2) 8mm x 35mm Hex Bolts
- (2) 8mm Lock Washers
- (2) 8mm Flat Washers

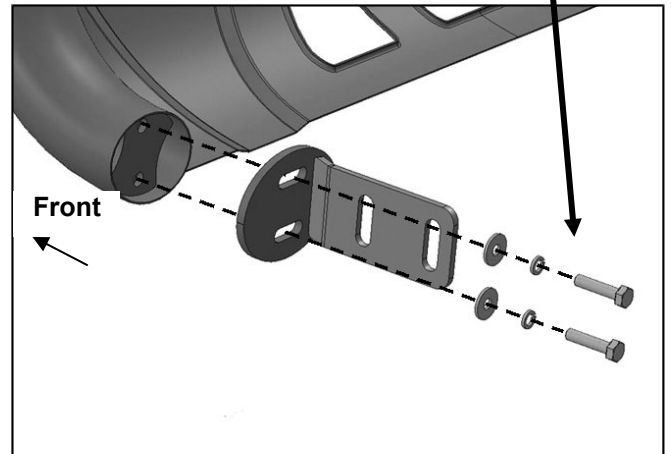

(Fig 13) Attach Bull Bar Bracket to end of Bull Bar

- Models w/o tow hooks:
- (2) 12mm x 35mm Hex Bolts
 - (4) 12mm Flat Washers
 - (2) 12mm Lock Washers
 - (2) 12mm Hex Nuts

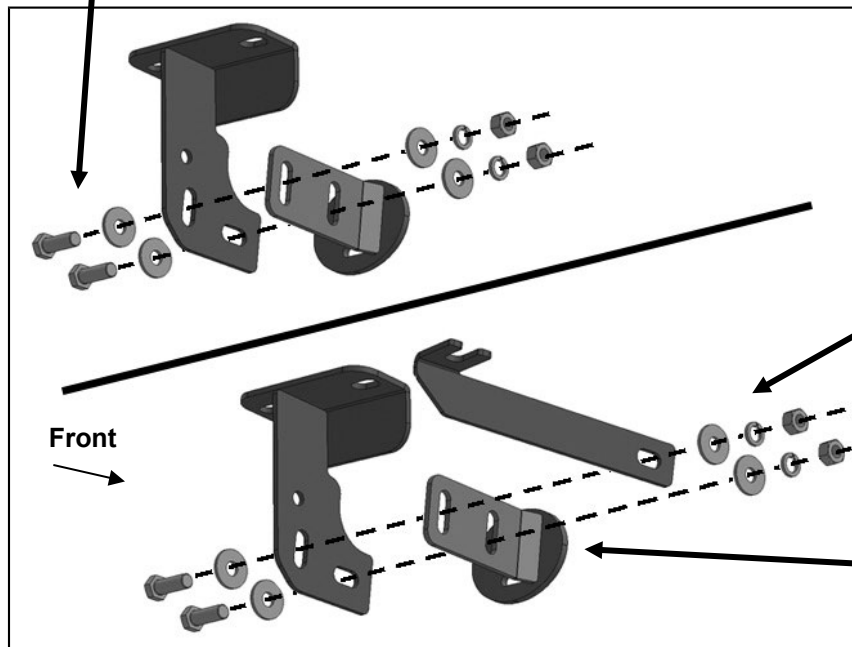

(Fig 14) Attach Bull Bar with Brackets to Frame Brackets

- Models with tow hooks:
- (2) 12mm x 35mm Hex Bolts
 - (4) 12mm Flat Washers
 - (2) 12mm Lock Washers
 - (2) 12mm Hex Nuts

Models with tow hooks, line up Bull Bar Bracket between Frame Bracket and Support Bracket

Installation pictured without the splash guard for instruction purposes only

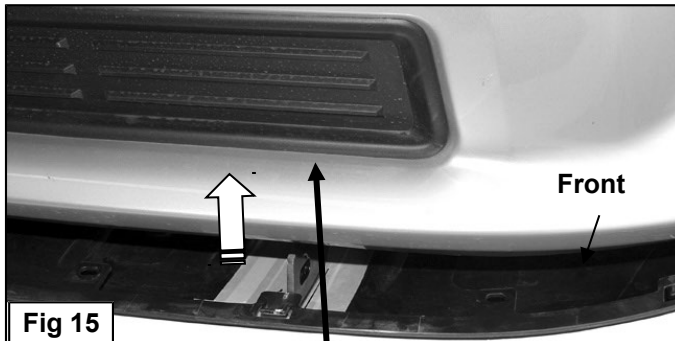

Fig 15

Hold the splash guard up to the bottom of the brackets and mark location for cutting to clear brackets. Cut only what is needed to insert bracket through the splash guard.

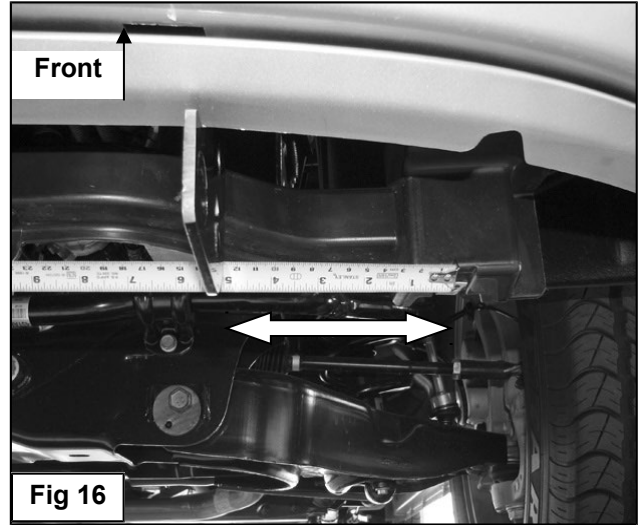

Fig 16

Measure the distance from the mounting point for the splash guard to the bracket on the driver and passenger side. Use this measurement as a reference point to check location before cutting the 1" wide x 4" long slot

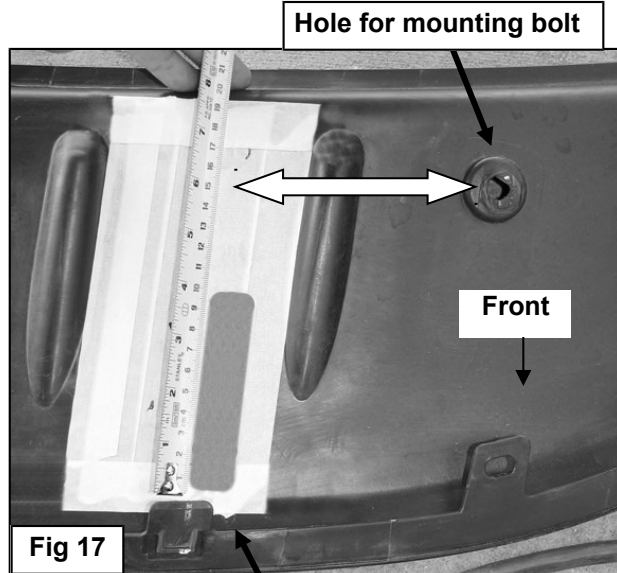

Fig 17

Cut only what is needed to insert bracket through the splash guard. Do not cut through the front edge of the splash guard

If required, replace the rivet at the corner of the splash guard with the supplied:
 5mm x 15mm Button Head Allen Bolt
 (2) 5mm Flat Washers
 5mm Nylon Lock Nut

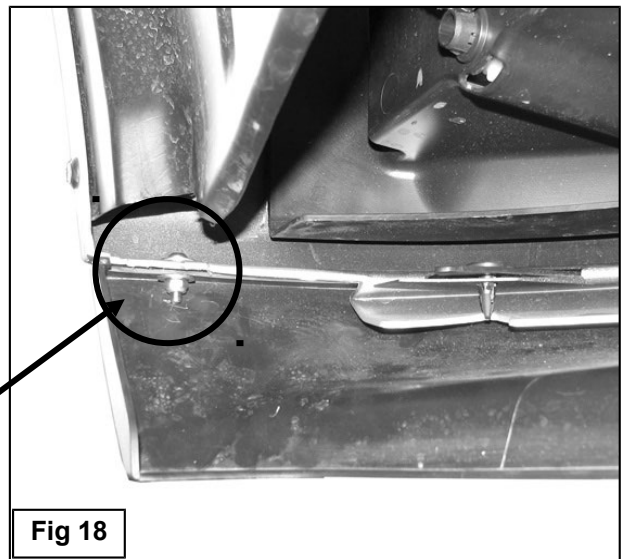
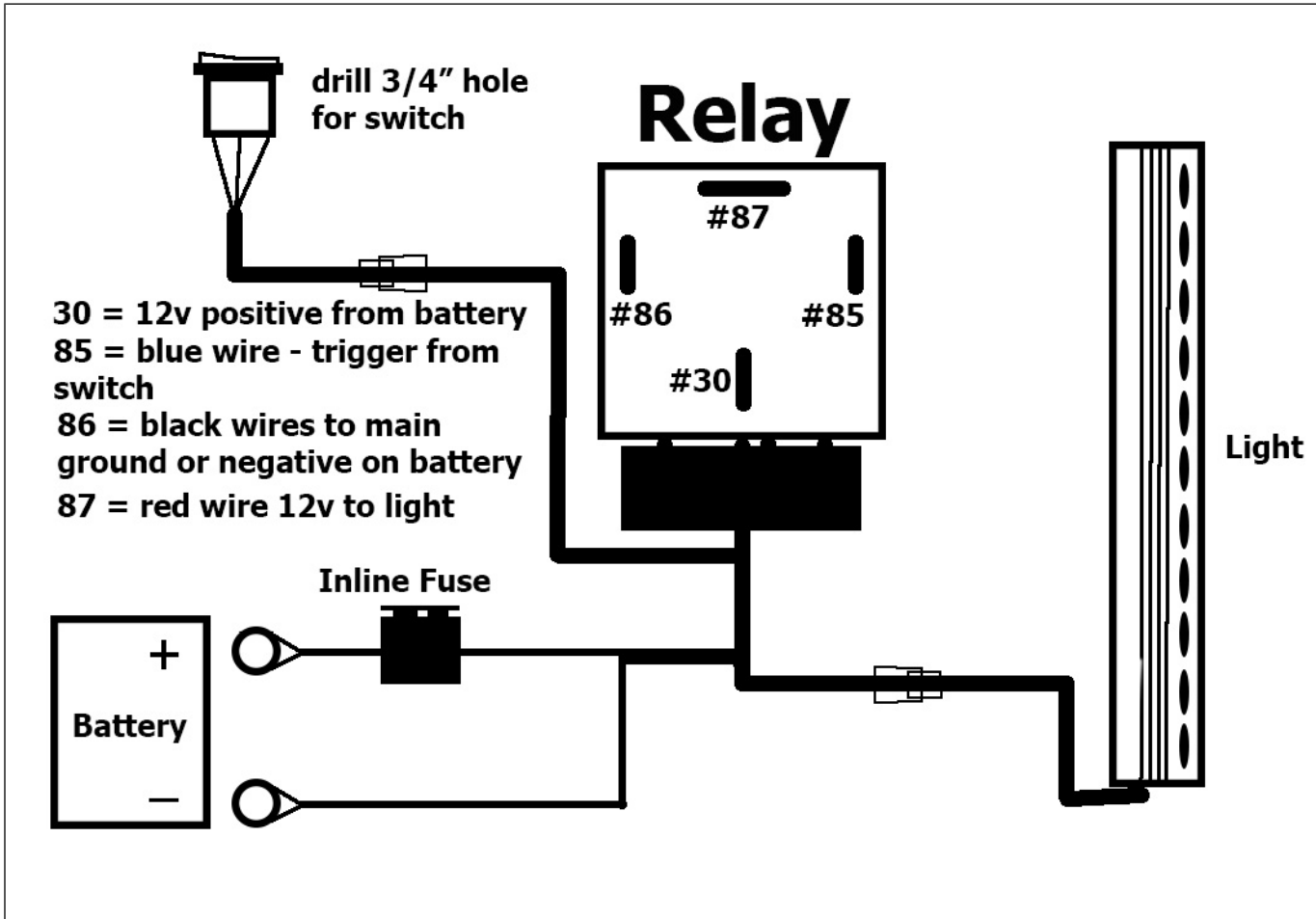

Fig 18

PARTS LIST:

Qty	Description
1	Light
1	Wiring Harness



PROCEDURE:

- 1. REMOVE CONTENTS FROM BOX. VERIFY ALL PARTS ARE PRESENT. READ INSTRUCTIONS CAREFULLY. DRILLING IS REQUIRED. ELECTRICAL KNOWLEDGE IS HIGHLY RECOMMENDED.**
2. Install Light into product as instructed. Open hood and disconnect battery.
3. Unwrap preassembled wiring harness. Disconnect the plug in the harness leading to the lighted switch. Locate suitable mounting location for switch. Drill 3/4" hole in panel to mount switch. **IMPORTANT:** Do not drill any holes in panel until back of location is properly checked for clearance. Use of safety goggles is required.
4. Run switch harness through firewall on vehicle. Drill hole through firewall as required for harness plug. Highly recommend use of rubber grommet (not included) to protect harness. Feed switch harness plug through hole in firewall. Seal firewall with silicone as necessary.
5. Attach Relay and main harness to suitable location near battery (firewall or inner fender for example). Do not connect to battery at this time.
6. Attach switch plug to switch harness and tie harness away from anything that could damage harness.
7. Run the prewired light harness down to the light. Plug harness into prewired plug on light. Tie wiring harness away from anything that could damage harness.
8. Attach the fused red positive and black negative wires on the main harness to the battery. **NOTE:** Attach black negative wire to negative terminal on battery or suitable chassis ground.
9. Reattach battery cables to battery. Installation is complete.
10. Do periodic inspections to the installation to make sure that all hardware is secure