

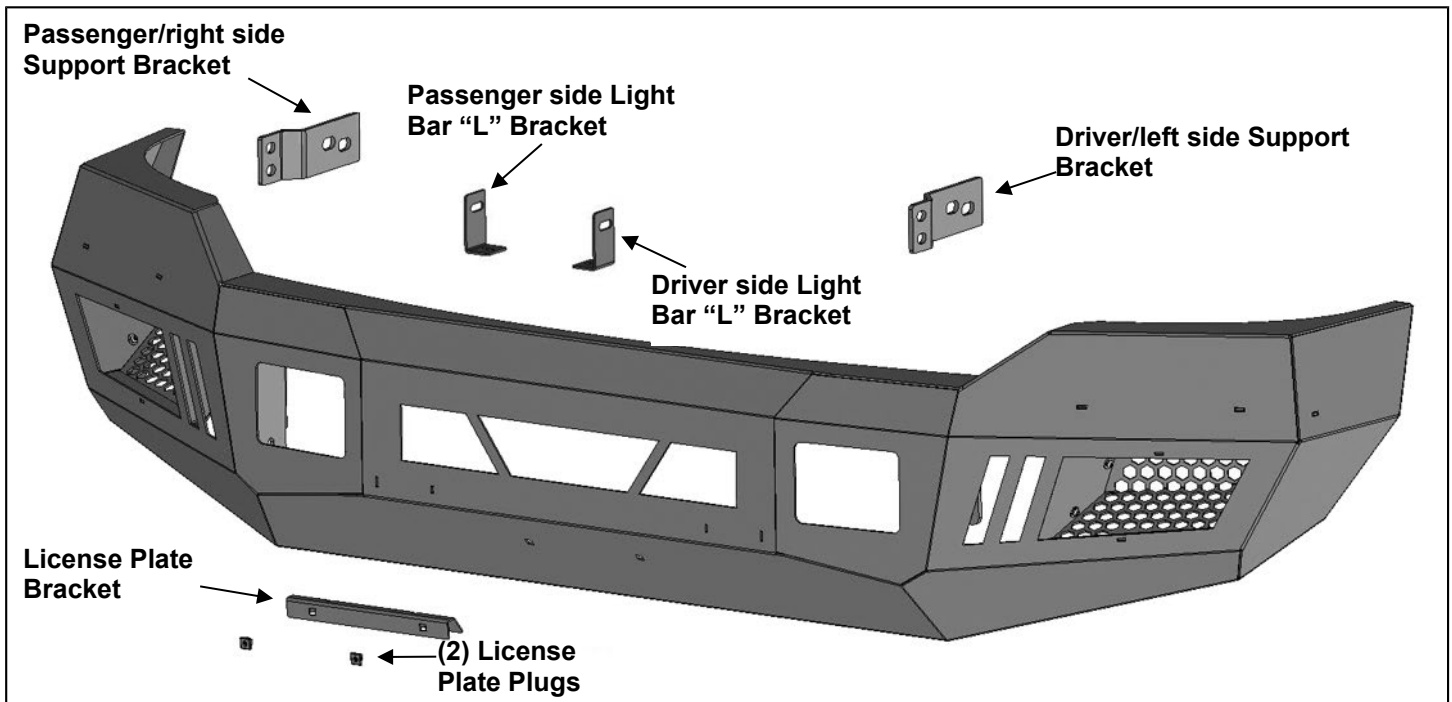

LDB-FORD48-FB

PARTS LIST:

1	LD1 Front Bumper Assembly	2	8-1.25mm x 25mm Hex Bolts
1	Driver/left side Support Bracket	2	8-1.25mm x 16mm Hex Bolts
1	Passenger/right side Support Bracket	6	8mm x 24mm x 2mm Flat Washers
1	Driver/left side Light Bar "L" Bracket	4	8mm Lock Washers
1	Passenger/right side Light Bar "L" Bracket	2	8mm Hex Nuts
1	License Plate Bracket	2	6mm x 20mm Button Head Bolts
2	License Plate Plastic Plugs	4	6mm x 18mm x 1.6mm Flat Washers
4	12-1.75mm x 35mm Hex Bolts	2	6mm Nylon Lock Nuts
8	12mm x 24mm x 2.5mm Flat Washers	1	4mm Wrench
4	12mm Lock Washers	10	200mm Nylon Cable Ties
4	12-1.75mm Hex Nuts		



PROCEDURE:

REMOVE CONTENTS FROM BOX. VERIFY ALL PARTS ARE PRESENT. READ INSTRUCTIONS CAREFULLY BEFORE STARTING INSTALLATION. BUMPER IS HEAVY, ASSISTANCE IS HIGHLY RECOMMENDED TO AVOID POSSIBLE INJURY OR DAMAGE TO THE VEHICLE.

1. Remove the license plate and bracket. On models with factory fog lights, unplug both lights. Release the wiring harness from the clips attached to the back of the bumper, (**Figures 1 & 2**). Move harness away from bumper.
2. Release the rubber air deflector from the back of the bumper. Next, remove the bumper supports attached to the bumper frame bracket and outer ends of the bumper, (**Figure 2**).
3. Place blocks or jack stands under the front bumper to support it during mounting bolt removal. Once the bumper has been safely supported, remove the (4) factory bumper bolts, (**Figure 3**).
WARNING! Assistance is required to hold the bumper in place during bolt removal to prevent the bumper from falling. Carefully slide the bumper off over the tow hooks.

**LD1 FRONT BUMPER
2011-16 FORD SUPERDUTY F250-350**

4. Remove the (4) factory hex nuts, lower frame extension and the (2) double bolt plates from the end of the frame, **(Figures 1, 4 & 5)**. Repeat this Step to remove the passenger side lower frame extension.
5. **Optional Center LED light installation** (sold separately). **NOTE:** Light must be installed before Bumper Assembly is attached to ends of frame.
 - a. Select the Driver side "L" Bracket. **NOTE:** "L" Brackets are offset for universal fitment for most LED bar style lights. Attach the Bracket to the top of the mounting tab on the back of the Bumper with the included (1) 8mm x 25mm Hex Bolt, (2) 8mm Flat Washers, (1) 8mm Lock Washer and (1) 8mm Hex Nut, **(Figures 6 & 7)**. Do not tighten hardware at this time.
 - b. Repeat Previous Step for Passenger side "L" Bracket installation.
 - c. Attach the LED Light Bar to the Brackets with (2) 8mm x 16mm Hex Bolts, (2) 8mm Lock Washers and (2) 8mm Flat Washers, **(Figures 6 & 7)**. Do not fully tighten hardware at this time.
 - d. Center and adjust light position and tighten hardware.
 - e. Follow light manufacturer's instructions to wire the light to the vehicle's electrical system once Bumper has been fully installed.
6. **LED light installation at ends of bumper** (sold separately).
 - a. Insert light into opening and up to mounting slot. Check for clearance between front and back of light. If necessary, remove the screen from the back of the opening, **(Figure 8)**.
 - b. Follow the light manufacturer's instructions to attach each light to slot in the top of the light opening.
 - c. Repeat the above steps for passenger side light installation.
 - d. Follow light manufacturer's instructions to properly wire the light to the vehicle electrical system once Bumper has been fully installed.
7. If front license plate is required, attach the License Plate Bracket to the holes in the bumper with the included (2) 6mm x 20mm Button Head Bolts, (4) 6mm Flat Washers and (2) 6mm Nylon Lock Nuts, **(Figure 9)**. Insert (2) Plastic Plugs into the square holes in the Bracket. Reuse the factory screws to attach the license plate to the plastic plugs.
8. With assistance, carefully position the Bumper Assembly up to the ends of the frame. Temporarily support the weight of the Bumper. **WARNING:** To avoid possible injury or damage to the vehicle, do not proceed until the bumper is fully and safely supported. Models with LED light, check for clearance before fully installing Bumper assembly. Reuse the (4) factory bumper bolts to attach the Bumper Assembly to the ends of the frame, **(Figure 10)**. Do not fully tighten hardware at this time.
9. Select the Driver side Support Bracket, (2) factory hex nuts and (1) factory double bolt plate, **(Figure 11)**. Slide the Support Bracket between the outer side of the Frame and the inside of the Bumper mount, **(Figures 12 & 13)**. Insert (1) factory double bolt plate in through the frame channel and out through the Bracket. Reuse the (2) factory hex nuts to secure the Bracket to the Frame, **(Figure 13)**. Attach the Bracket to the Bumper with (2) 12mm Hex Bolts, (4) 12mm Flat Washers, (2) 12mm Lock Washers and (2) 12mm Hex Nuts, **(Figures 12 & 13)**. Do not tighten hardware.
10. Level and adjust the bumper and fully tighten all hardware.
11. Remove covers from top of Bumper for additional access if desired.
12. Do periodic inspections to the installation to make sure that all hardware is secure and tight.

To protect your investment, wax this product after installing. Regular waxing is recommended to add a protective layer over the finish. Do not use any type of polish or wax that may contain abrasives that could damage the finish. Mild soap may be used to clean the LD1 Front Bumper assembly.

Driver Side Installation Pictured

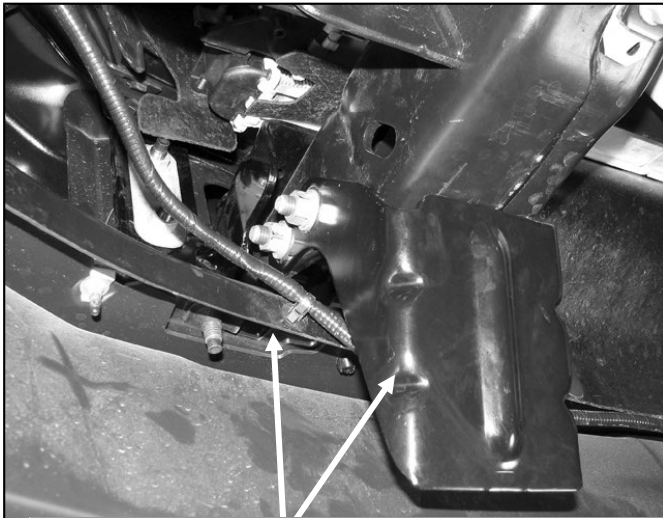

(Fig 1) Driver side lower frame extension and fog light wire harness pictured from behind bumper

Remove hardware attaching bumper support brackets to frame

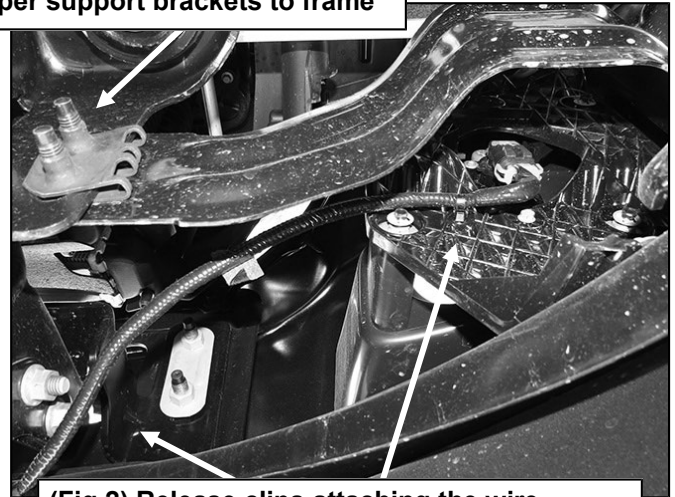

(Fig 2) Release clips attaching the wire harness for fog lights if equipped. Passenger side pictured from behind bumper

WARNING! Do not remove bumper bolts unless the bumper is properly supported on blocks or stands or the bumper may fall.

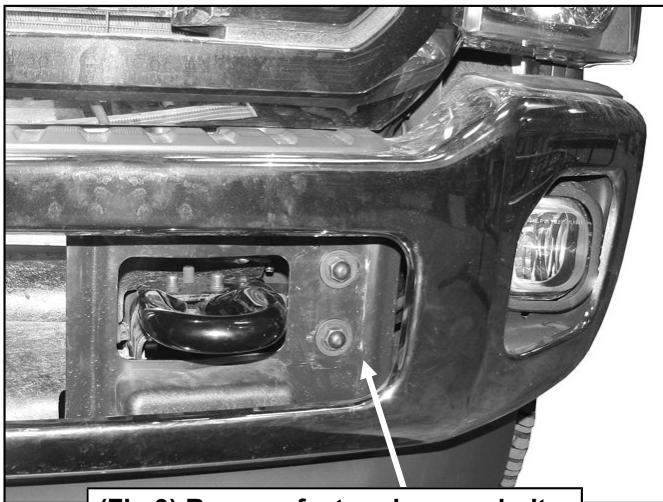

(Fig 3) Remove factory bumper bolts

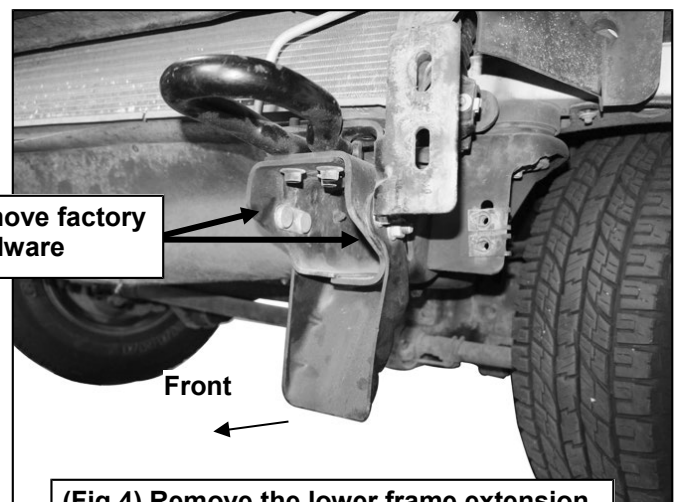

Remove factory hardware

(Fig 4) Remove the lower frame extension

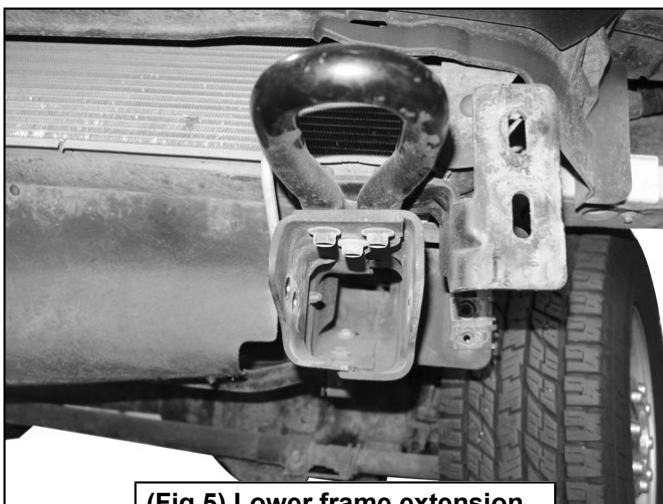

(Fig 5) Lower frame extension removed on driver side

Driver Side Installation Pictured

- (2) 8mm x 16mm Hex Bolts
- (2) 8mm Lock Washers
- (2) 8mm Flat Washers

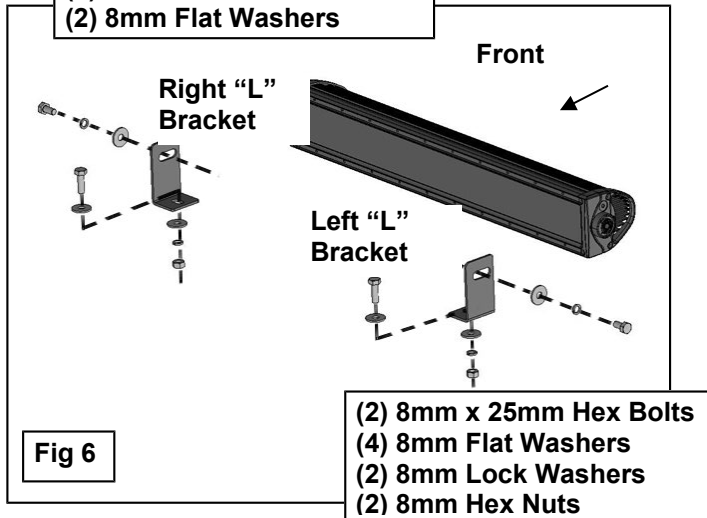

(Fig 7) Center LED light bar installed (pictured from behind the Bumper)

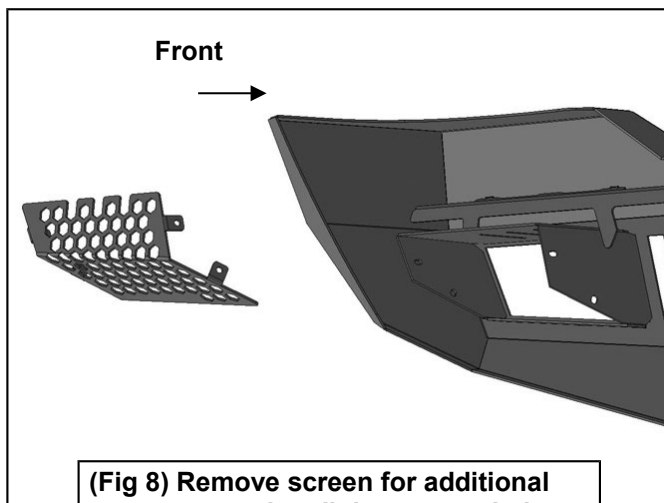

(Fig 8) Remove screen for additional access or to clear lights as needed

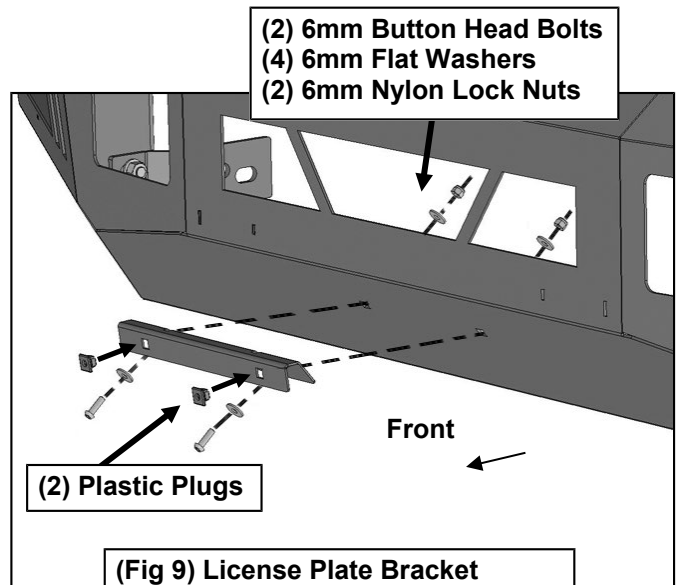

(Fig 9) License Plate Bracket attached to the front of the Bumper

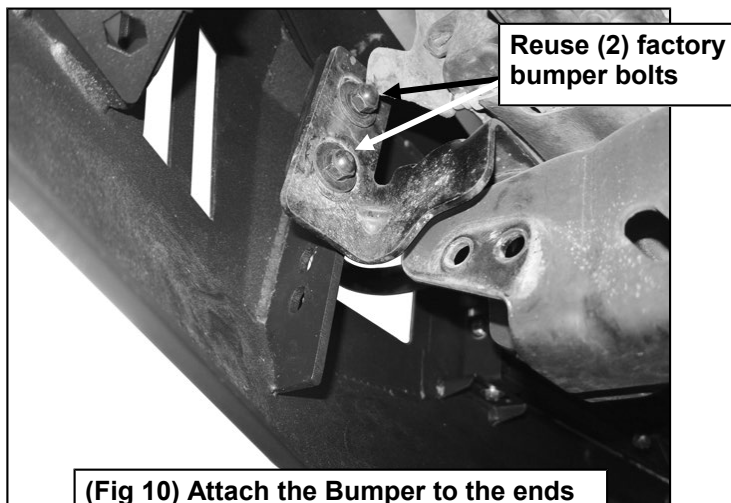

(Fig 10) Attach the Bumper to the ends of the Frame (Driver side pictured)

Driver Side Installation Pictured

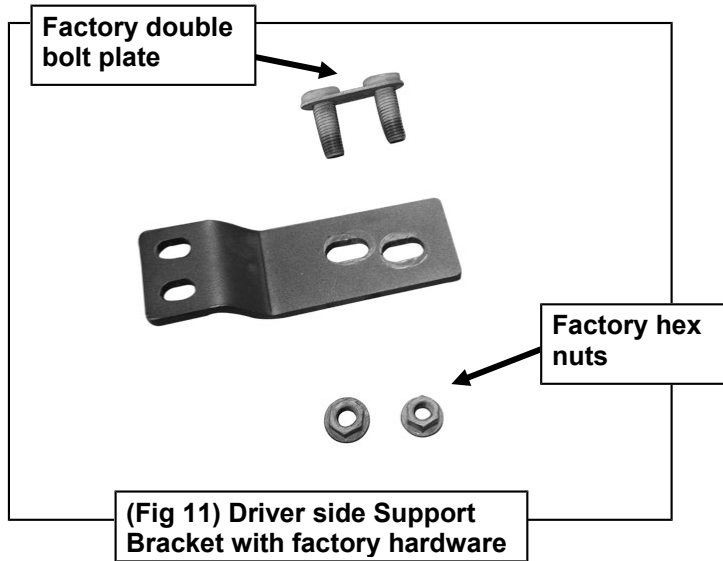

WARNING! Do not crawl under bumper unless the bumper is properly supported on blocks or stands or the bumper may fall.

- (2) 12mm Hex Bolts
- (4) 12mm Flat Washers
- (2) 12mm Lock Washers
- (2) 12mm Hex Nuts

