

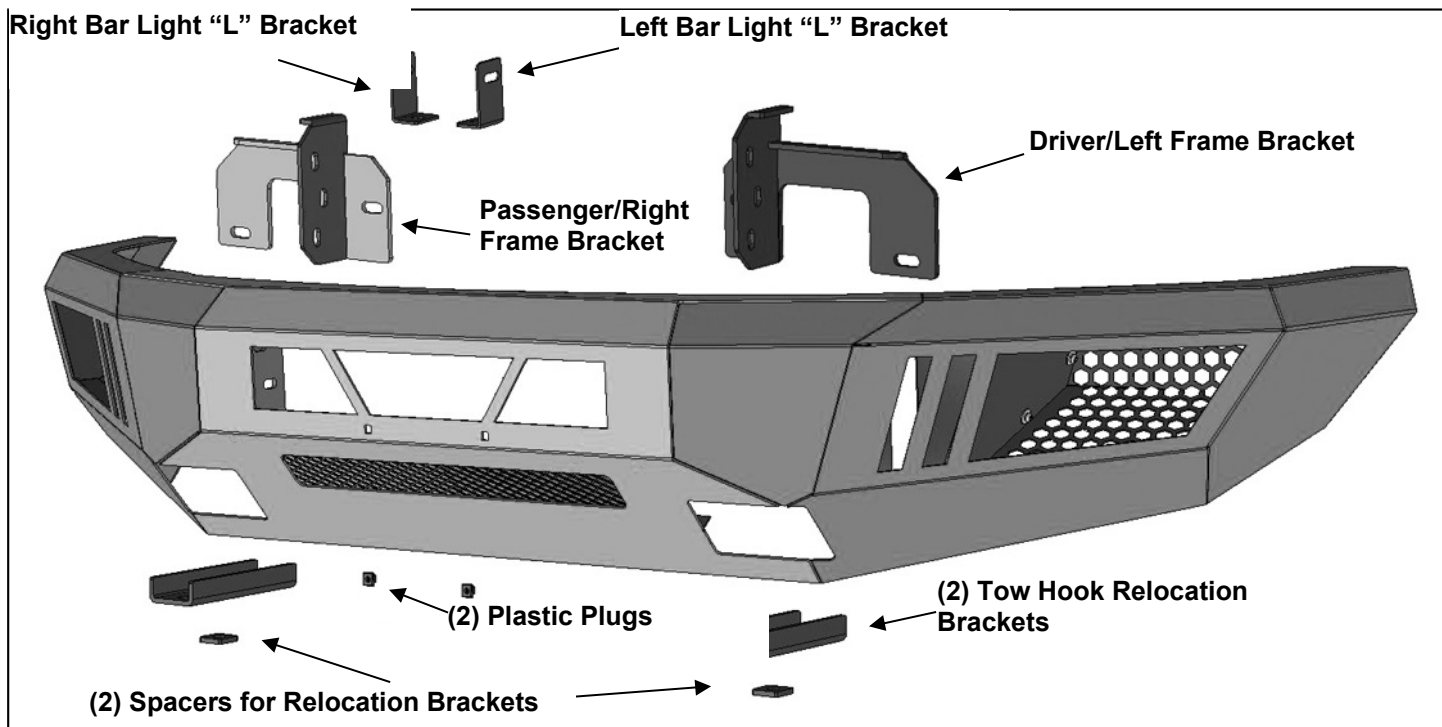

PARTS LIST:

1	Front Bumper Assembly	6	10-1.5mm x 35mm Hex Bolts
1	Driver/left Frame Bracket	12	10mm x 27mm OD x 3mm Flat Washers
1	Passenger/right Frame Bracket	6	10mm Lock Washers
1	Driver/left "L" Bracket (center LED light)	6	10mm Hex Nuts
1	Passenger/right "L" Bracket (center LED light)	2	8-1.25mm x 25mm Hex Bolts
2	Tow Hook Relocation Brackets	2	8-1.25mm x 16mm Hex Bolts (LED light bar)
2	Tow Hook Relocation Bracket Spacers	6	8mm x 24mm Flat Washers
2	Plastic Plugs for license plate mount	4	8mm Lock Washers
6	12-1.75mm x 45mm Hex Bolts	2	8mm Hex Nuts
12	12mm x 37mm x 3mm Flat Washers	1	Wrench
6	12mm Lock Washers	10	Nylon Wire Ties
6	12mm Hex Nuts		



PROCEDURE:

REMOVE CONTENTS FROM BOX. VERIFY ALL PARTS ARE PRESENT. READ INSTRUCTIONS CAREFULLY BEFORE STARTING INSTALLATION. BUMPER IS HEAVY, ASSISTANCE IS HIGHLY RECOMMENDED TO AVOID POSSIBLE INJURY OR DAMAGE TO THE VEHICLE. LED BAR STYLE CENTER LIGHT MAY INTERFERE WITH AIRFLOW TO INTERCOOLER ON ECOBOOST MODELS.

1. Remove the hardware attaching the inner splash panels in the fenders to the back of the bumper, **(Figure 1)**. Also remove the license plate and bracket. On models with factory fog lights, unplug both lights and release the wiring harness from the clips attached to the back of the bumper, **(Figure 2)**. Move harness away from bumper.
2. Open the hood and remove the hardware attaching the hood release lever to the steel bracket attached to the back of the bumper, **(Figure 3)**. Also remove the screws attaching the back of the plastic fascia to the hood release bracket and remove the bracket from the bumper, **(Figure 4)**.

3. Place blocks or jack stands under the front bumper to support it during mounting bolt removal. Once the bumper has been safely supported, remove the (2) large hex nuts from the back of each bumper bracket, **(Figure 5)**. **WARNING!** Assistance is required to hold the bumper in place during bolt removal to prevent the bumper from falling. Carefully slide the bumper off over the tow hooks, if equipped.
4. On models equipped with factory tow hooks, remove the tow hooks and double nut plates from inside the ends of the frame, **(Figure 6)**.
5. Select (1) Tow Hook Relocation Bracket. Insert the Bracket into the end of the frame, **(Figure 7)**. **NOTE:** Insert end of Bracket with round hole into frame first. Slide the double nut plate into the end of the frame and over the Relocation Bracket. Reuse the factory tow hook bolt to attach the inner end of the Bracket to the inner tow hook hole.
6. Line up the inner mounting hole in the tow hook with the center hole in the Bracket. Reuse (1) factory tow hook bolt to attach the tow hook to the frame and center hole in the Bracket, **(Figure 7)**. Slide (1) Bracket Spacer between the forward end of the Bracket and the tow hook, **(Figure 8)**. Attach the tow hook to the Spacer and Bracket with (1) 12mm x 45mm Hex Bolt, (2) 12mm Flat Washers, (1) 12mm Lock Washer and (1) 12mm Hex Nut Fully tighten the tow hook hardware only at this time.
7. Next, select the driver/left Frame Mounting Bracket, **(Figure 9)**. Attach the Bracket to the bumper bracket on the end of the frame with (2) 12mm x 45mm Hex Bolts, (4) 12mm Flat Washers, (2) 12mm Lock Washers and (2) 12mm Hex Nuts. Leave hardware loose at this time.
8. Repeat **Steps 5—7** to install the passenger/right Frame Mounting Bracket, Tow Hook Relocation Bracket and tow hook if equipped.
9. Reuse the factory hardware to attach the steel hood release bracket to the mounting tabs on the back of the plastic fascia. Reattach the hood release lever to the steel bracket, **(Figure 10)**. Tighten hardware at this time.
10. With assistance, position the Bumper Assembly up to the mounting flanges on the Frame Brackets, **(Figure 11)**. Temporarily support the weight of the Bumper. **WARNING:** To avoid possible injury or damage to the vehicle, do not proceed until the bumper is fully and safely supported. Attach the Bumper to the Frame Brackets with (6) 10mm x 35mm Hex Bolts, (12) 10mm Flat Washers, (6) 10mm Lock Washers and (6) 10mm Hex Nuts, **(Figures 11 & 12)**. Do not fully tighten at this time.
11. Level and adjust the bumper and fully tighten all hardware.
12. If front license plate is required, insert (2) Plastic Plugs into the square holes in the Bumper. Reuse the factory screws to attach the license plate to the plastic plugs, **(Figure 13)**.
13. **Center LED light installation** as supplied with bumper or sold separately. **IMPORTANT:** Center LED bar style light installation may interfere with airflow to intercooler on Ecoboost equipped models.
 - a. Select the L/R “L” Brackets, **(Figure 14)**. Attach the Brackets to the top of the (2) mounting tabs welded onto the back of the bumper with the included 8mm x 25mm Hex Bolts, (4) 8mm Flat Washers, (2) 8mm Lock Washers and (2) 8mm Hex Nuts. Leave loose at this time.
 - b. Attach the LED light assembly to the “L” Brackets with the included (2) 8mm x 16mm Hex Bolts, (2) 8mm Lock Washers and (2) 8mm Flat Washers, **(Figure 14)**. Do not fully tighten hardware at this time. **NOTE:** “L” Brackets are designed for 8mm light mounting hardware only. Modify “L” Brackets if necessary or use brackets supplied by your light manufacturer if possible to install hardware larger than 8mm.
 - c. Follow light manufacturer’s instructions to properly wire the light.
14. **LED light installation at ends of bumper** as supplied with bumper or sold separately.
 - a. Insert light into opening and up to mounting slots. Check for clearance between front and back of light. If necessary, remove the screen from the back of the opening, **(Figure 15)**.
 - b. Follow the light manufacturer’s instructions to attach (1) light to the center slot or (2) lights to the inner and outer slots in the top of the light opening, **(Figure 16)**. **IMPORTANT:** On two light per side systems, attach the flood light to the outer slot and the spot light to the inner slot.
 - c. Repeat the above steps for passenger/right side light installation.
 - d. Follow light manufacturer’s instructions to properly wire the light.
15. Do periodic inspections to the installation to make sure that all hardware is secure and tight.

To protect your investment, wax this product after installing. Regular waxing is recommended to add a protective layer over the finish. Do not use any type of polish or wax that may contain abrasives that could damage the finish. Mild soap may be used to clean the Bumper assembly.

Driver Side Installation Pictured

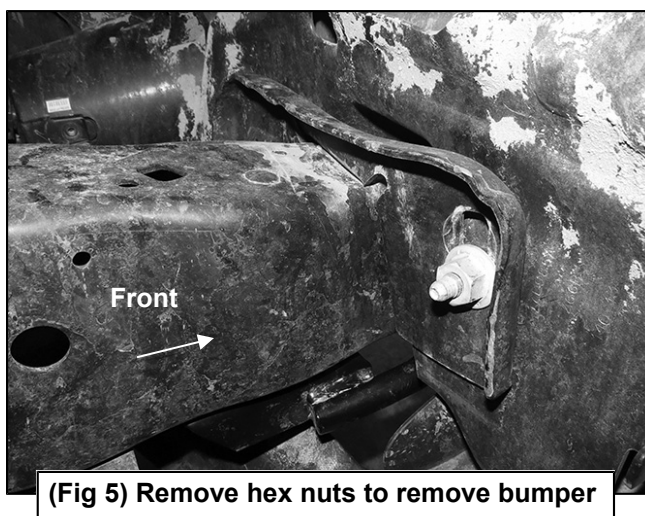
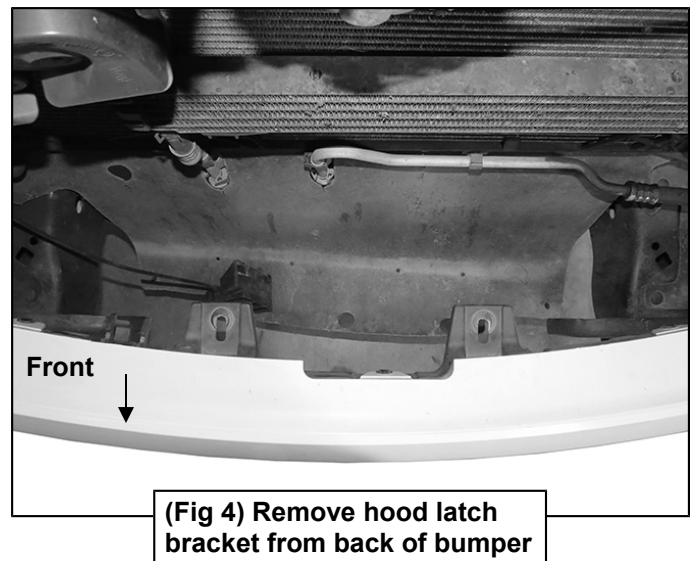
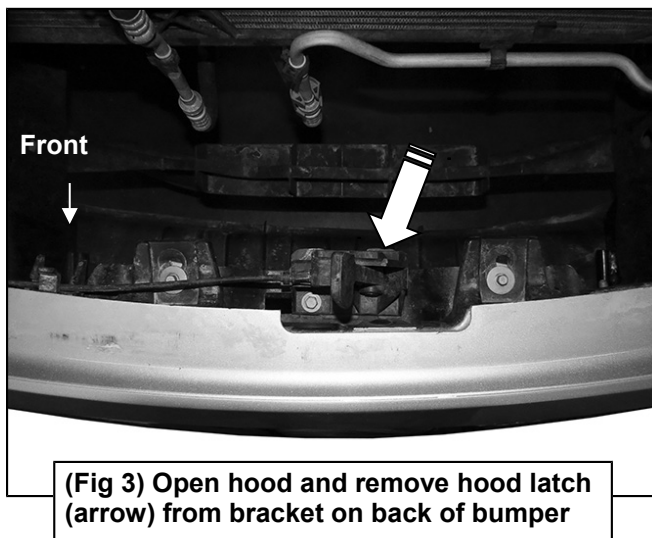
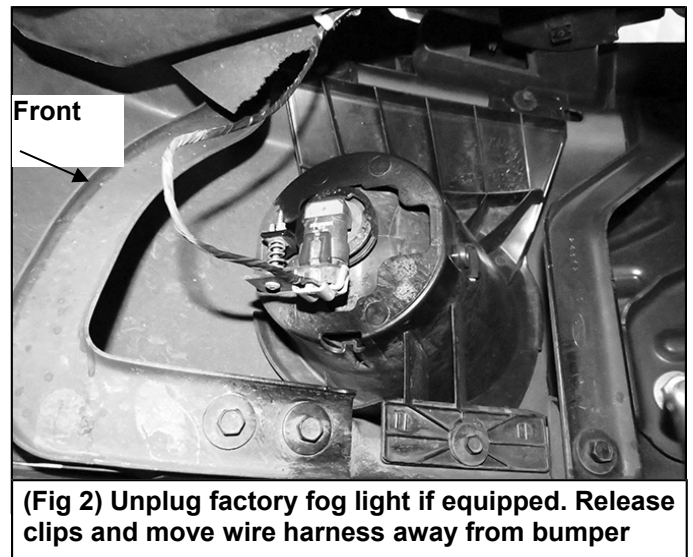
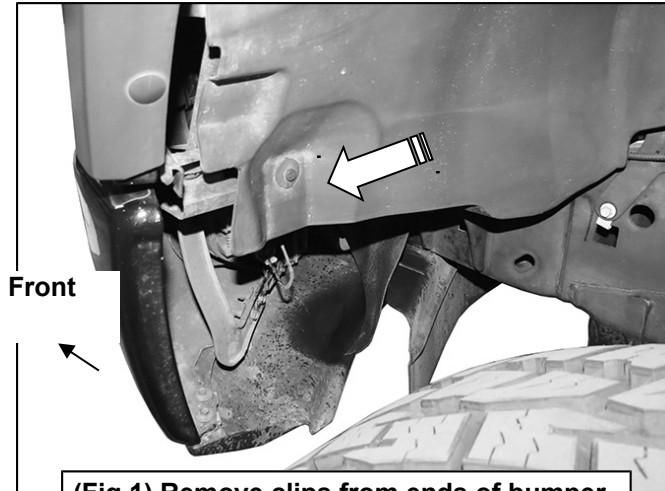

WARNING! Do not remove bumper bolts unless the bumper is properly supported on blocks or stands or the bumper may fall.

Driver Side Installation Pictured



(Fig 6) Remove bumper assembly. Also remove tow hooks and double nut plates if equipped

WARNING! Do not remove bumper bolts unless the bumper is properly supported on blocks or stands or the bumper may fall.

Reuse factory tow hook double nut plate
Tow Hook Relocation Bracket. Attach tow hook to oval slots

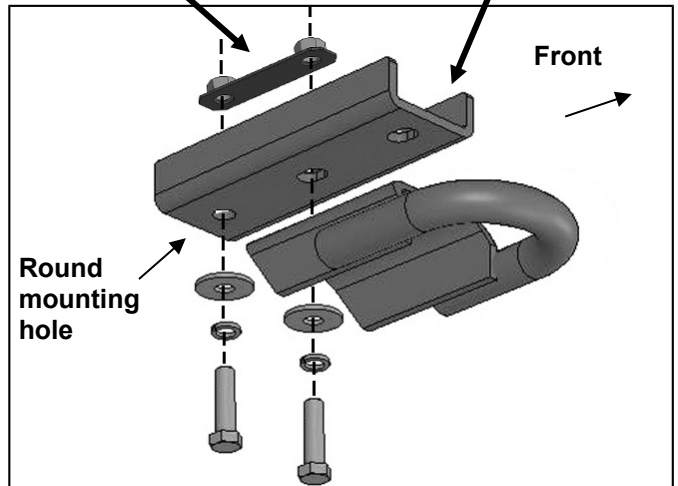

(Fig 7) Models with tow hooks only, reuse factory hardware to attach tow hook to double nut plate

12mm x 45mm Hex Bolt
(2) 12mm Flat Washers
12mm Lock Washer
12mm Hex Nut

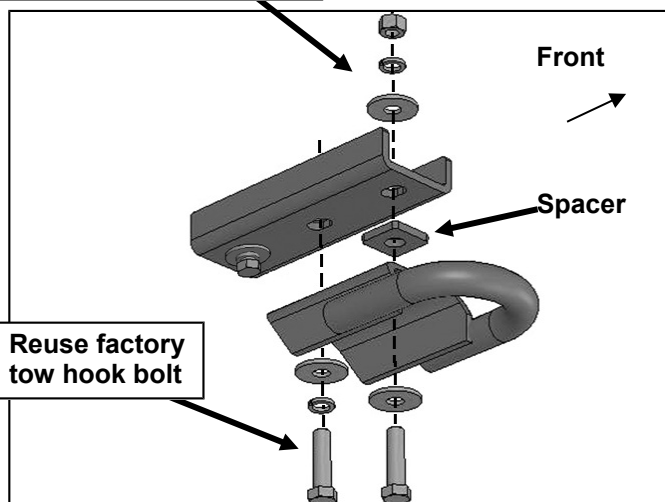

(Fig 8) Insert Spacer between tow hook and forward end of Relocation Bracket

Factory double nut plate

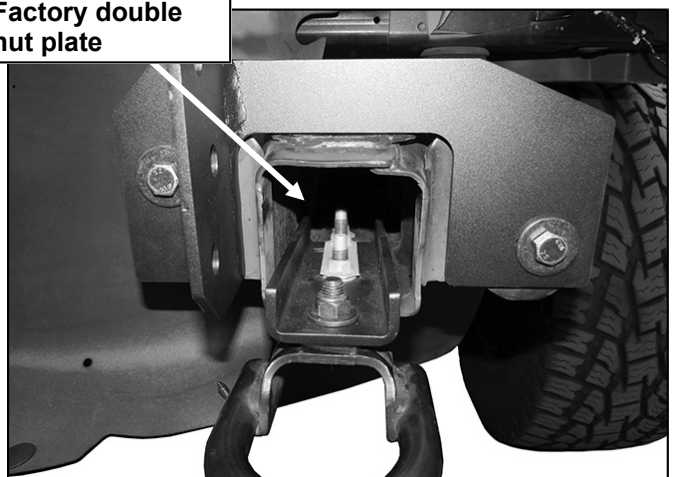

(Fig 9) Tow hook attached to Relocation Bracket

Driver Side Installation Pictured

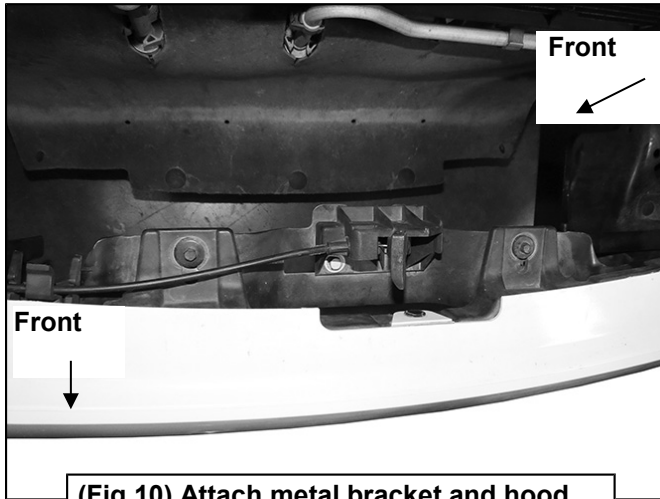

(Fig 10) Attach metal bracket and hood latch to back of plastic fascia body panel

WARNING! Do not crawl under bumper unless the bumper is properly supported on blocks or stands or the bumper may fall.

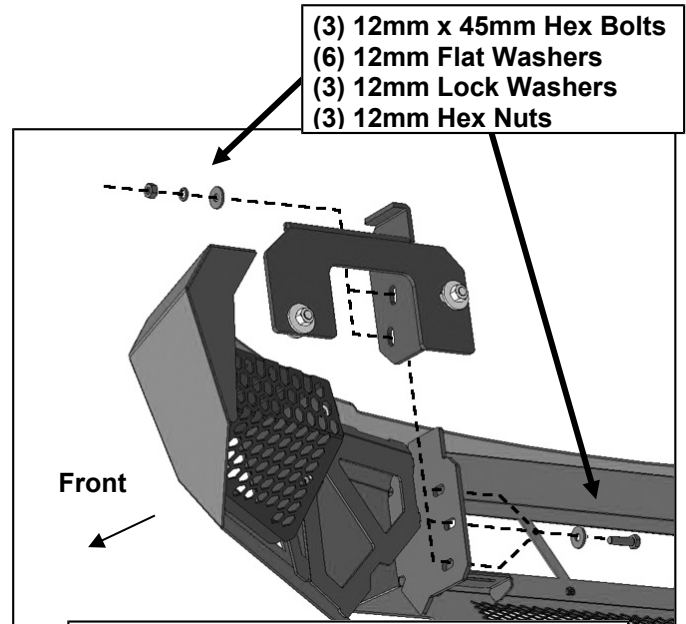

(Fig 11) Attach Bumper to Frame Brackets

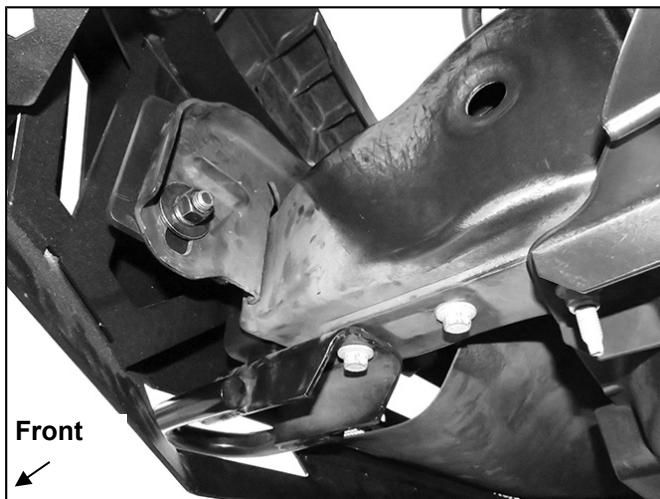

(Fig 12) Align and adjust the Bumper and fully tighten all hardware

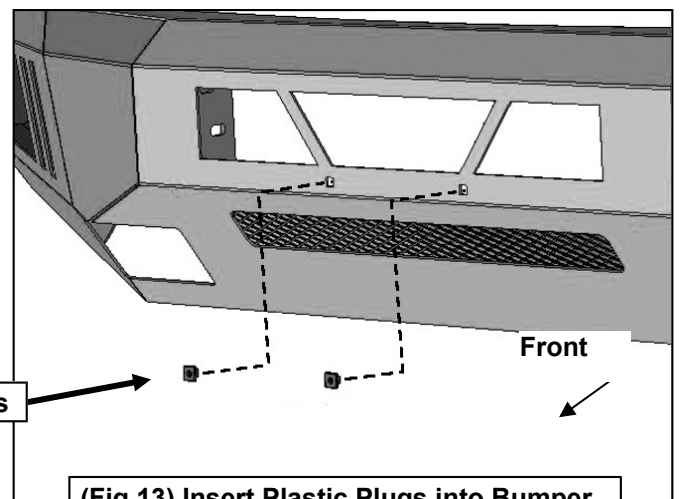

(Fig 13) Insert Plastic Plugs into Bumper. Attach License Plate to Plastic Plugs

Driver Side Installation Pictured

- (2) 8mm x 16mm Hex Bolts
- (2) 8mm Lock Washers
- (2) 8mm Flat Washers

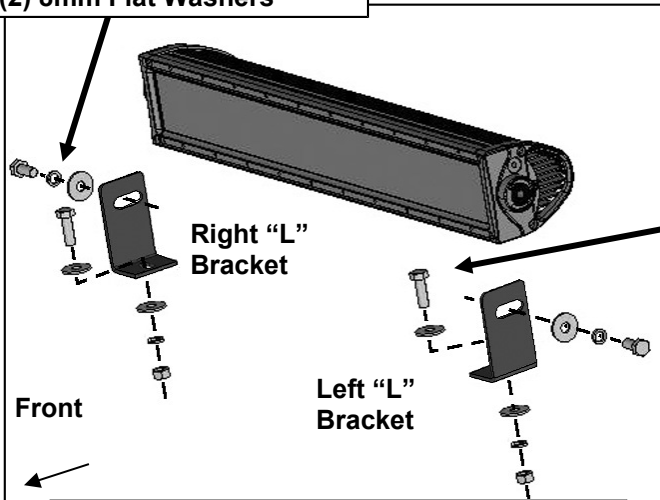

(Fig 14) Example of center light installation

- (2) 8mm x 25mm Hex Bolts
- (4) 8mm Flat Washers
- (2) 8mm Lock Washers
- (2) 8mm Hex Nuts

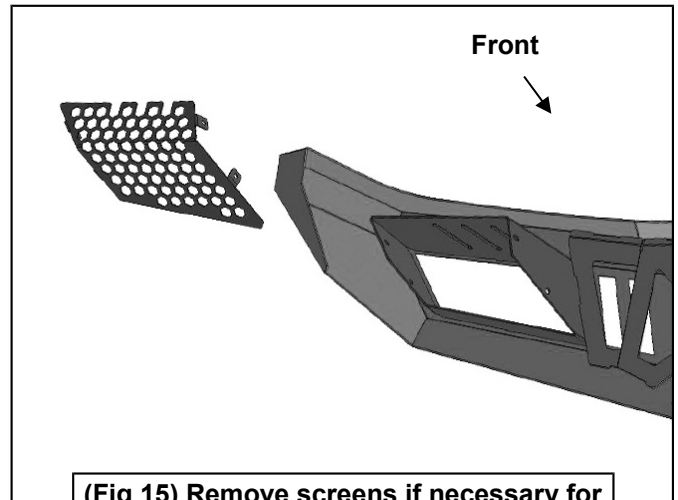

(Fig 15) Remove screens if necessary for clearance/access to outer light mounts

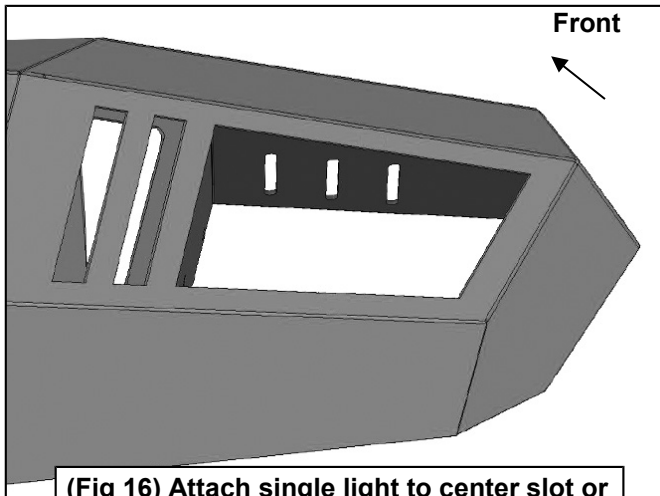

(Fig 16) Attach single light to center slot or use inner and outer slots for dual lights

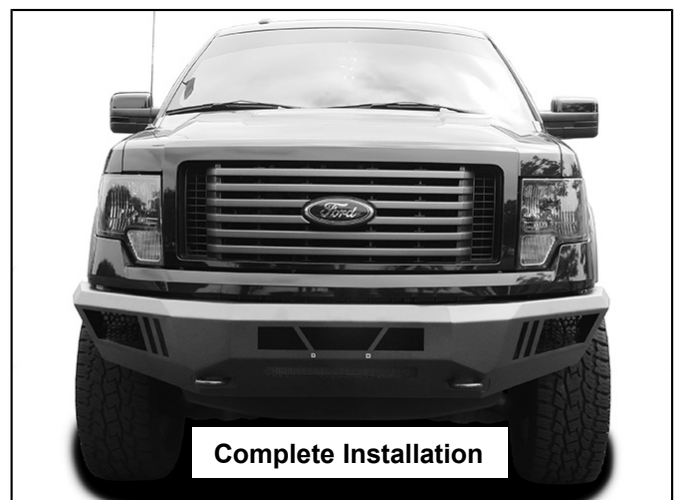

Complete Installation