

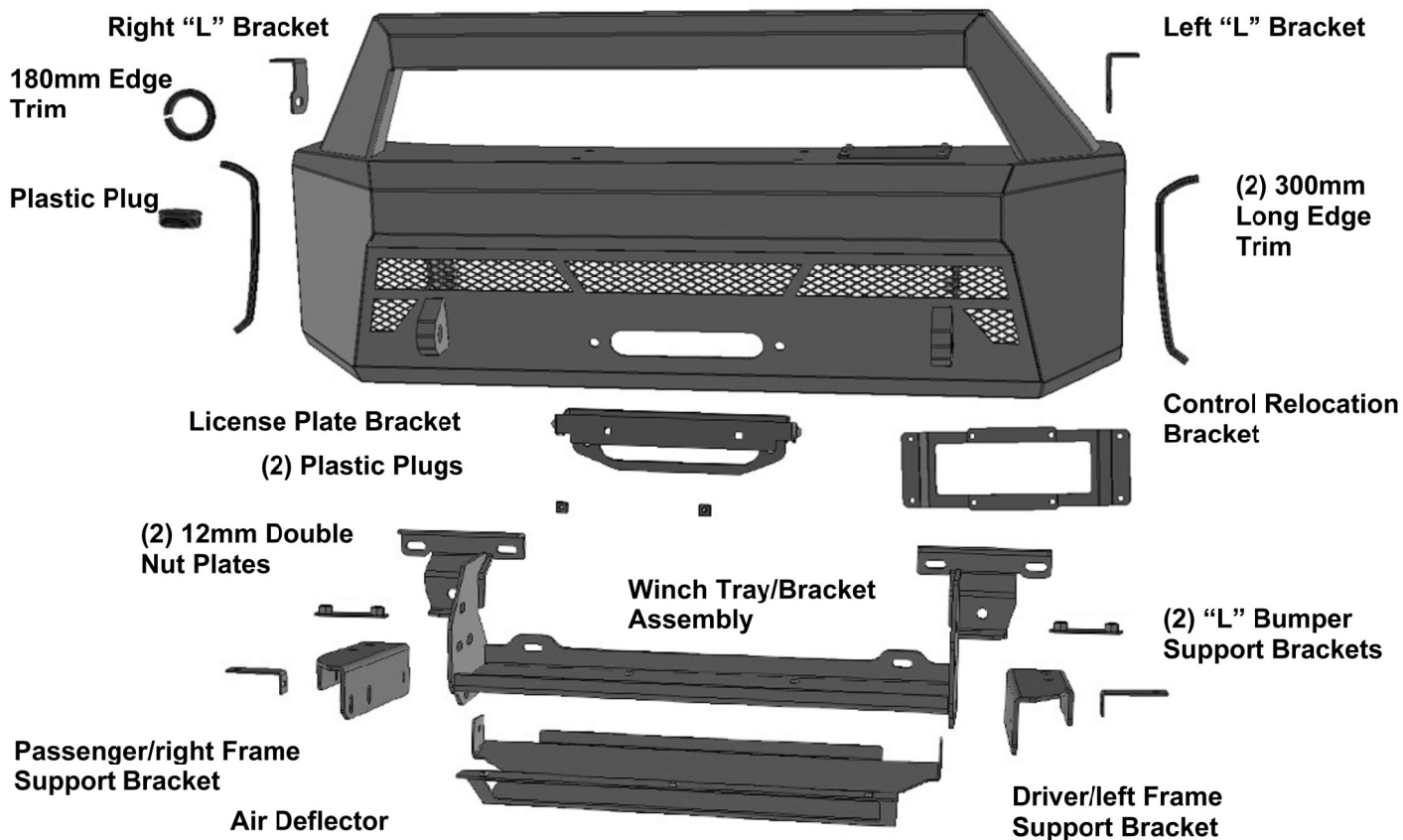

PARTS LIST: CSX-FDHD9-FB

| | | | |
|----|---------------------------------------|----|--|
| 1 | CS-1 Winch Center Bumper | 4 | 12mm Hex Nuts |
| 1 | Winch Tray/Bracket Assembly | 2 | 10-1.5mm x 30mm Button Head Bolts |
| 1 | Driver/left Frame Support Bracket | 2 | 10mm Nylon Lock Nuts |
| 1 | Passenger/right Frame Support Bracket | 2 | 8-1.25mm x 25mm Hex Bolts |
| 1 | Air Deflector | 2 | 8-1.25mm x 16mm Hex Bolts |
| 1 | Control Pack Relocation Bracket | 6 | 8mm x 24mm x 2mm Flat Washers |
| 2 | Bumper "L" Support Bracket | 4 | 8mm Lock Washers |
| 2 | LED "L" Mounting Bracket s | 2 | 8mm Hex Nuts |
| 1 | License Plate Bracket (pivot style) | 4 | 6-1.0mm x 20mm Button Head Bolts |
| 2 | Plastic Plugs for license plate mount | 3 | 6-1.0mm x 20mm Combo Bolts |
| 1 | 2" Plastic Hole Plug | 6 | 6-1.0mm x 25mm Hex Bolts |
| 1 | 180mm Edge Trim (use as hole grommet) | 20 | 6mm x 18mm x 1.6mm Flat Washers |
| 2 | 300mm Bumper Outer Edge Trim | 10 | 6mm Nylon Lock Nuts |
| 2 | 12-1.75mm Double Nut Plates | 1 | 6mm Allen Wrench (for 10mm Button Bolts) |
| 14 | 12-1.75mm x 45mm Hex Bolts | 1 | 4mm Allen Wrench (for 6mm Button Bolts) |
| 18 | 12mm x 24mm x 2.5mm Flat Washers | 10 | Wire Ties |
| 14 | 12mm Lock Washers | | |



PROCEDURE:

REMOVE CONTENTS FROM BOX. VERIFY ALL PARTS ARE PRESENT. READ INSTRUCTIONS CAREFULLY BEFORE STARTING INSTALLATION. ASSISTANCE IS RECOMMENDED TO AVOID POSSIBLE INJURY OR DAMAGE TO THE VEHICLE. CUTTING IS REQUIRED.

1. Remove the license plate and bracket, **(Figure 1)**. Remove the plastic bumper pad assembly, **(Figure 2)**. **NOTE:** Carefully pull bumper pad straight out away from bumper. Unplug and remove the adaptive cruise control, if equipped, **(Figure 3)**.
2. Unplug the fog lights, if equipped, **(Figure 4)**. Release the wiring harness from the clips attached to the back of the bumper. Move all wiring harnesses away from bumper.
3. Place blocks or jack stands under the front bumper to support it during mounting bolt removal. Once the bumper has been safely supported, remove the large hex nut from the back of the driver/left and passenger/right bumper brackets attaching the lower bumper to the bumper brackets, **(Figure 5)**. Next, from the front of the bumper, remove the (4) factory hex nuts, (2) per side, attaching the bumper to the bumper brackets, **(Figure 6)**. **WARNING!** Assistance is required to hold the bumper in place during bolt removal to prevent the bumper from falling. Carefully slide the bumper off over the tow hooks if equipped, and move it to a stable work surface.
4. Remove the plastic splash guard from the bottom of the factory bumper, **(Figure 7)**. **NOTE:** Splash guard cannot be reinstalled.
5. Disassemble the bumper to remove the bumper reinforcements. Remove the (2) clip nuts from the lower bumper reinforcement plates, **(Figure 7)**.
6. Cover the bottom-front of the bumper with removable tape, (masking tape for example). Place a mark on the tape 2-1/4" in from the edge of the opening for the driver/left side bumper pad, **(Figure 8)**. Repeat to mark the passenger/right side of the bumper. Use a hack saw to cut the lower section off of the outer bumper, **(Figure 8)**.
7. Slide the clip nuts over the bumper brackets on end of the frame, **(Figure 9)**. Reassemble the bumper.
8. Remove both tow hooks if equipped. **IMPORTANT:** On models without tow hooks, insert (1) 12mm Double Nut Plate into the end of each frame rail, **(Figure 9)**. Line up the Double Nut Plate with the (2) holes in the bottom of the frame. Use (1) 12mm x 45mm Hex Bolt to temporarily hold each Nut Plate in position over the holes.
9. On models with ecoboost, remove the lower cooler shroud, **(Figure 10)**. Shroud cannot be reinstalled with winch and Winch Tray.
10. Reinstall the factory bumper but leave hardware loose at this time, **(Figure 10)**.
11. Select the Winch Tray/Bracket Assembly. Reuse the (4) factory hex nuts to attach the Assembly to the front of the bumper brackets through the bumper, **(Figures 11 & 12)**. Reuse the (2) factory hex bolts to attach the Winch Tray to the clip nuts on the inner bumper brackets. Do not fully tighten hardware.
12. Select the driver/left Frame Support Bracket. Attach the Bracket to the bottom of the frame and Double Nut Plate with the factory tow hook bolts or the included (2) 12mm x 45mm Hex Bolts, (2) 12mm Lock Washers, and (2) 12mm Flat Washers, **(Figure 13)**. Attach the side of the Support Bracket to the Winch Tray with the included (2) 12mm x 45mm Hex Bolts, (4) 12mm Flat Washers, (2) 12mm Lock Washers and (2) 12mm Hex Nuts, **(Figures 14 & 15)**. Do not fully tighten hardware at this time. Repeat this Step to install the passenger/right Frame Support Bracket.
13. Select (1) "L" Bumper Support Bracket. Attach the Support Bracket to the outside of the driver/left Frame Support Bracket and the bottom of the factory bumper with the included (2) 6mm x 25mm Hex Bolts, (4) 6mm Flat Washers and (2) 6mm Nylon Lock Nuts, **(Figure 16)**. Repeat this Step to attach the passenger/right side "L" Bumper Support Bracket.
14. Align and center Winch Tray to vehicle. Adjust factory bumper to vehicle as necessary and fully tighten all hardware.
15. If installing winch, (winch not included), attach the winch to the Winch Tray at this time. Winch must be installed before Bumper is placed in position. **NOTE:** Follow manufacturer's instructions to remove the control assembly from the top of the winch for relocation and to properly attach the winch to the vehicle's electrical system. Temporarily place Bumper in position to check for clearance.
16. Carefully unpack the Bumper. Attach the included long Edge Trim to the sides of the Bumper, **(Figure 17)**. If installing winch, apply Edge Trim to hole in top of Bumper. If winch will not be installed, insert Plastic Plug into hole, **(Figure 18)**.
17. Select the Winch Control Relocation Bracket. Attach the Bracket to the top of the Bumper with the included (4) 6mm x 20mm Button Head Bolts, (8) 6mm Flat Washers and (4) 6mm Nylon Lock Nuts, **(Figure 18)**. If necessary, remove cover plate for winch release access.

18. Attach winch cable guide, (not included), to Bumper assembly. **NOTE:** On vehicles requiring front license plate, select the Pivoting License Plate Bracket. Use the included (2) 10mm x 30mm Button Head Bolts and (2) 10mm Nylon Lock Nuts to attach the Bracket to the front of the cable guide and Bumper, **(Figure 19)**.
19. Push the included (2) push-in Plastic Plugs into the square holes in the Bracket and reuse the factory hardware to attach the license plate to the Plastic Plugs, **(Figure 19)**.
20. With assistance, position the Bumper Assembly up to the frame, **(Figure 20)**. Temporarily support the weight of the Bumper. **WARNING:** To avoid possible injury or damage to the vehicle, do not proceed until the bumper is fully and safely supported.
21. Attach the driver/left side of the Bumper to the outside of the Winch Tray with the included (3) 12mm x 45mm Hex Bolts, (3) 12mm Lock Washers and (3) 12mm Flat Washers, **(Figures 20 & 21)**. Do not fully tighten hardware at this time. Repeat this Step to attach the passenger/right side of the Bumper.
22. Level and adjust the Bumper and fully tighten all hardware.
23. Select the Air Deflector. Attach the Air Deflector to the bottom of the Bumper with the included (3) 6mm x 20mm Button Head Combo Bolts, **(Figure 22)**. Attach the rear tabs on the Air Deflector to the inside of the Support Brackets with (2) 6mm x 25mm Hex Bolts, (4) 6mm Flat Washers and (2) 6mm Nylon Lock Nuts, **(Figure 23)**.
24. Determine if bar style LED light, (not included), will be installed at this time. **NOTE:** Bull Nose assembly is designed to be compatible with most 20" to 24" Bar Style LED lights.
LED bar style light installation (light not included).
 - a. Select the driver/left "L" Light Bar Bracket, **(Figure 24)**. **NOTE:** "L" Brackets are offset to adjust for different widths of LED Bar Lights and can be installed on either side or facing in or out as needed.
 - b. "L" Brackets to the inside will accommodate a light 21-3/8" to 23-3/16" wide.
 - c. "L" Brackets to the outside will accommodate a light 24-5/8" to 26-3/8" wide.
 - d. Attach the L Bracket to the slot on the back of the Bull Nose assembly with (1) 8mm x 25mm Hex Bolt, (2) 8mm Flat Washers, (1) 8mm Lock Washer and (1) 8mm Hex Nut, **(Figure 24)**. Repeat this Step to install the remaining "L" Bracket.
 - e. Attach the light to the "L" Brackets with the included (2) 8mm x 16mm Hex Bolts, (2) 8mm Lock Washers and (2) 8mm Flat Washers or use the hardware included with the light, **(Figures 24)**. Do not fully tighten hardware at this time.
25. Do periodic inspections to the installation to make sure that all hardware is secure and tight.

To protect your investment, Do not use any type of polish or wax that may contain abrasives that could damage the finish. Mild soap may be used to clean the Bumper assembly.



(Fig 1) Remove license plate from Bumper

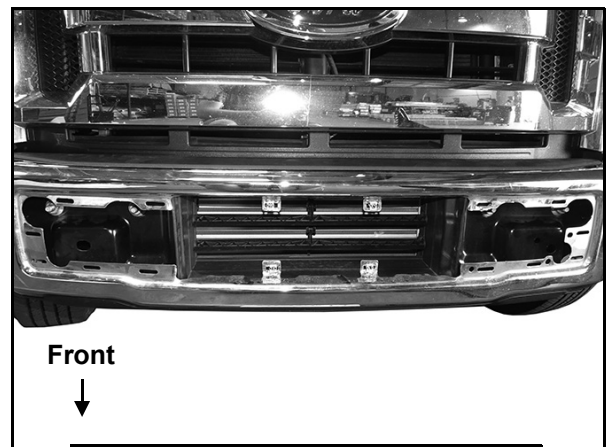

(Fig 2) Remove the plastic bumper pads from the front of the Bumper

Driver Side Installation Pictured



(Fig 3) Unplug and remove adaptive cruise control from driver/left side of frame, if equipped

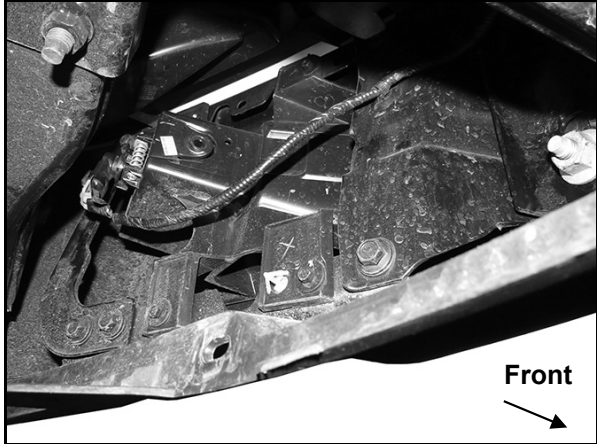

(Fig 4) Unplug all wiring harnesses leading to front bumper (fog light pictured)

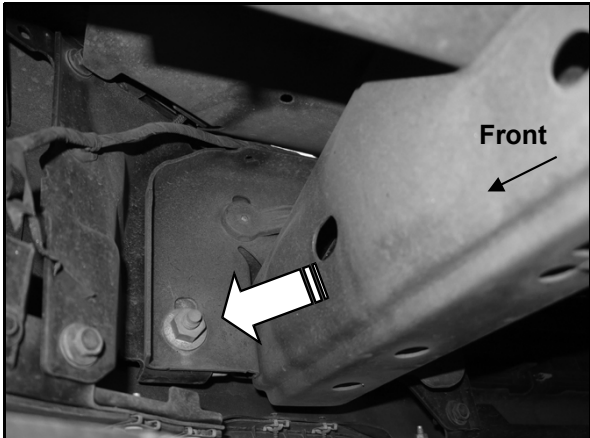

(Fig 5) Remove factory hex nut (arrow) from back of bumper brackets (driver/left side pictured)

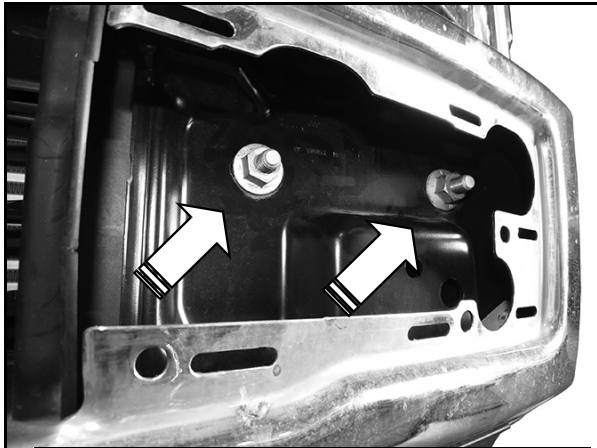

(Fig 6) Remove (2) factory hex nuts from each side and remove bumper assembly

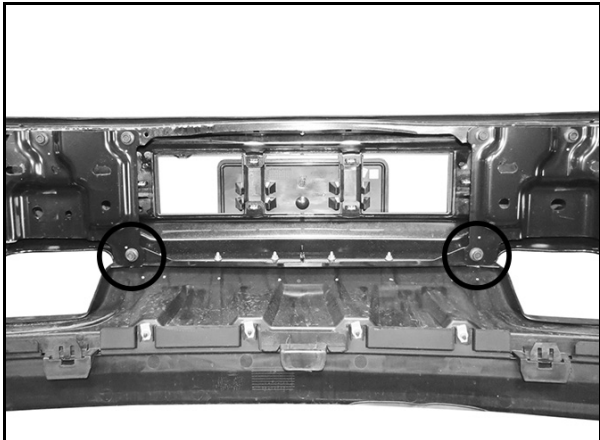

(Fig 7) Disassemble the bumper. Remove the (2) factory clip nuts from the outer bumper

WARNING! Do not remove bumper bolts unless it is properly supported on blocks or stands or the bumper may fall.

Driver Side Installation Pictured

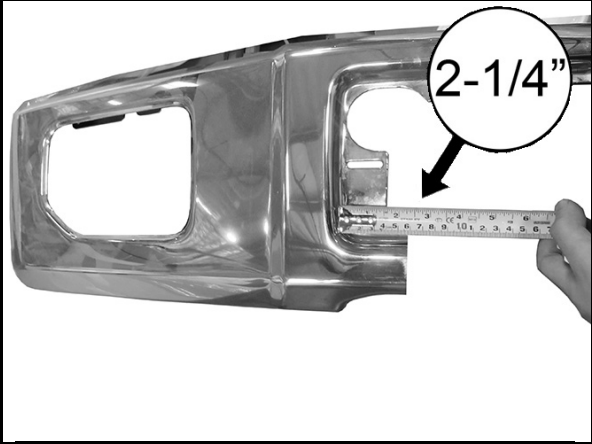

(Fig 8) Measure 2-1/4" in from the edge of the opening on both ends of the bumper. Mark line. Cut out lower section from bumper (passenger/right side pictured)

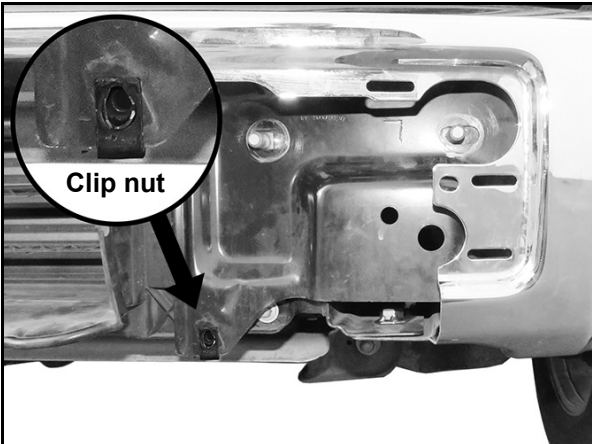

(Fig 9) Slide clip nuts over bottom mounting holes in bumper bracket (also see Fig 7)

Ecoboost models, remove shroud

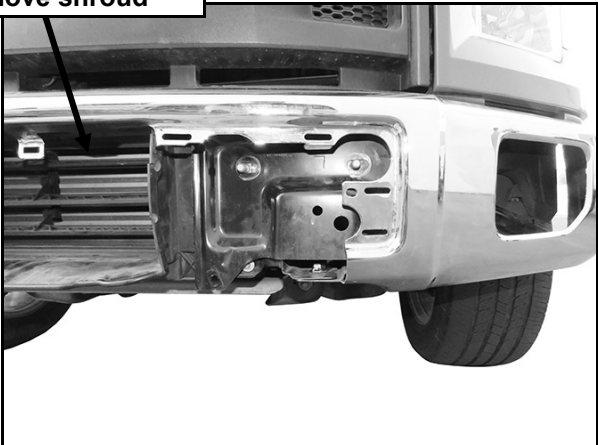

(Fig 10) Reinstall bumper. Models without tow hooks, slide 12mm Double Nut Plate into frame and line up over mounting holes in frame.

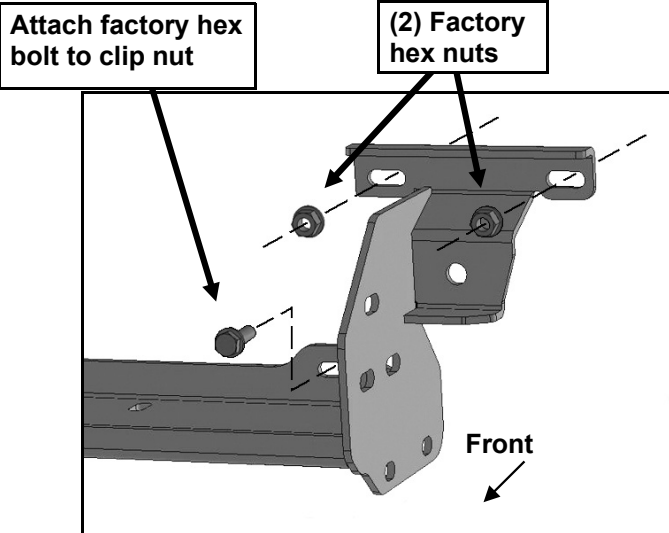

(Fig 11) Reuse factory hardware to attach Winch tray/Bracket assembly to factory bumper brackets (driver/left side pictured)

Driver Side Installation Pictured

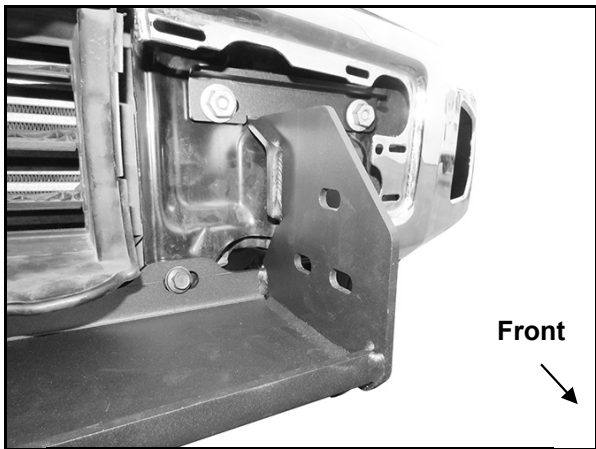

(Fig 12) Winch tray/Bracket assembly installed (driver/left side pictured)

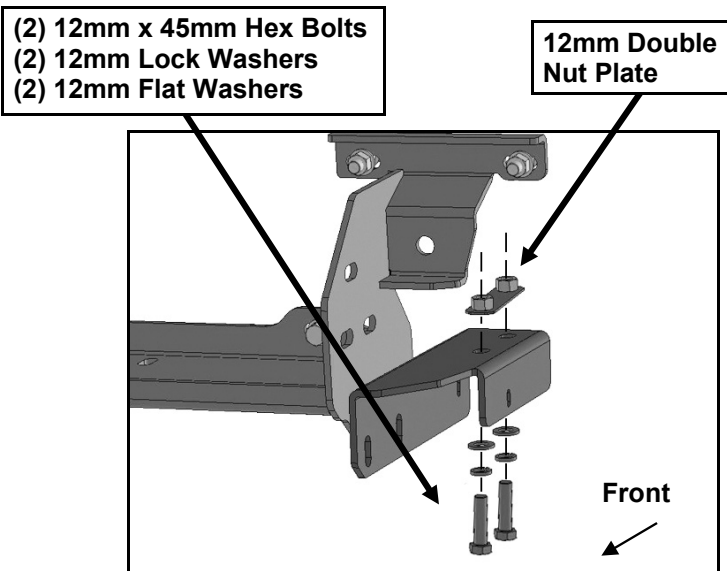

(Fig 13) Attach driver/left Frame Support Bracket to double nut plate in frame channel

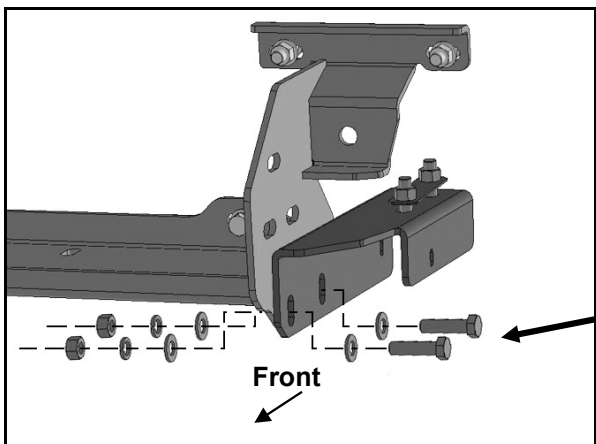

(Fig 14) Attach driver/left Frame Support Bracket to side of Winch Tray assembly

- (2) 12mm x 45mm Hex Bolts
- (4) 12mm Flat Washers
- (2) 12mm Lock Washers
- (2) 12mm Hex Nuts

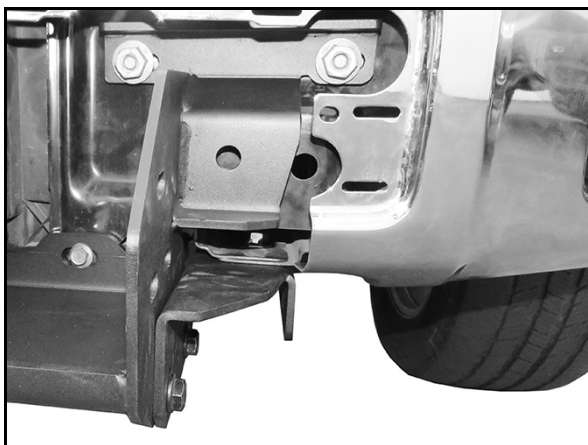

(Fig 15) Driver/left side Winch Tray/Bracket Assembly and Frame Support Bracket installed

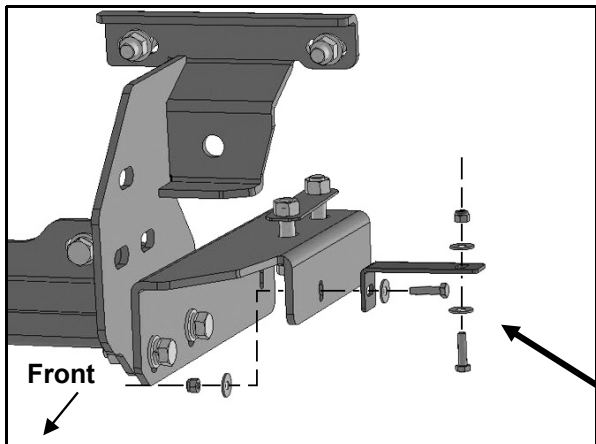

(Fig 16) Attach "L" Bumper Support Bracket to outside of Support Bracket and factory bumper

- (2) 6mm x 25mm Hex Bolts
- (4) 6mm Flat Washers
- (2) 6mm Nylon Lock Nuts

Driver Side Installation Pictured

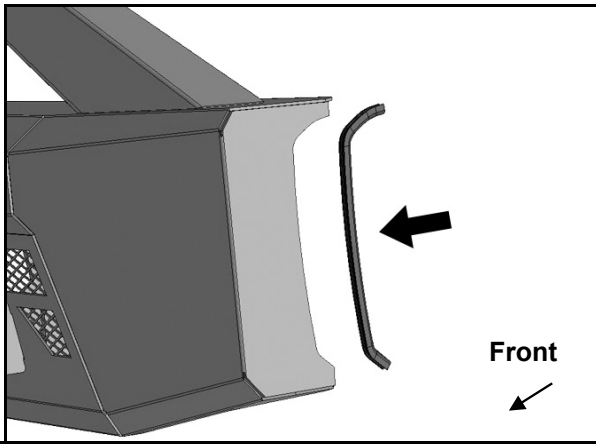

(Fig 17) Push long Edge Trim onto ends of Bumper

- (4) 6mm x 20mm Button Head Bolts
- (8) 6mm Flat Washers
- (4) 6mm Nylon Lock Nuts

Apply Edge Trim around access hole

Plug

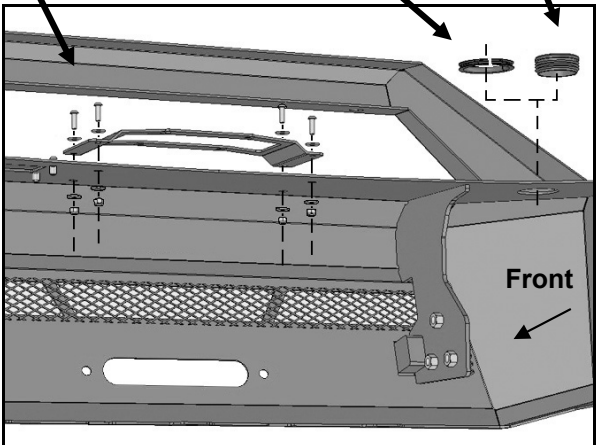

(Fig 18) Attach Winch Control Relocation Bracket to top of Bumper (optional)

(2) Plastic Plugs

- (2) 10mm x 30mm Button Head Bolts
- (2) 10mm Nylon Lock Nuts

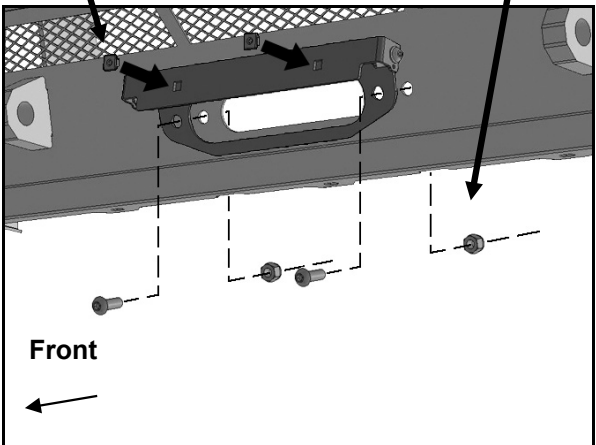

(Fig 19) Attach License Plate Bracket to Bumper

- (3) 12mm x 45mm Hex Bolts
- (3) 12mm Lock Washers
- (3) 12mm Flat Washers

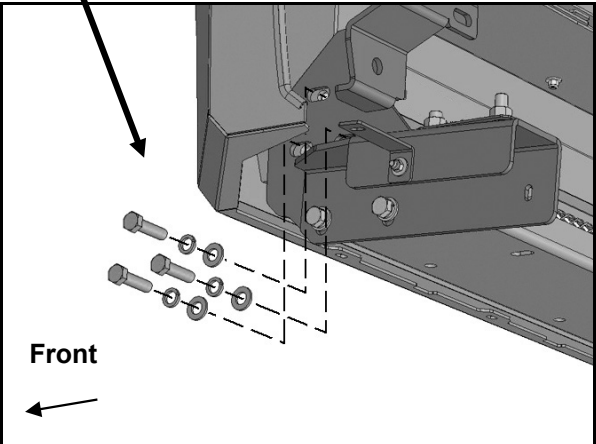

(Fig 20) Attach Bumper to inside of Winch Tray Bracket Assembly

Driver Side Installation Pictured

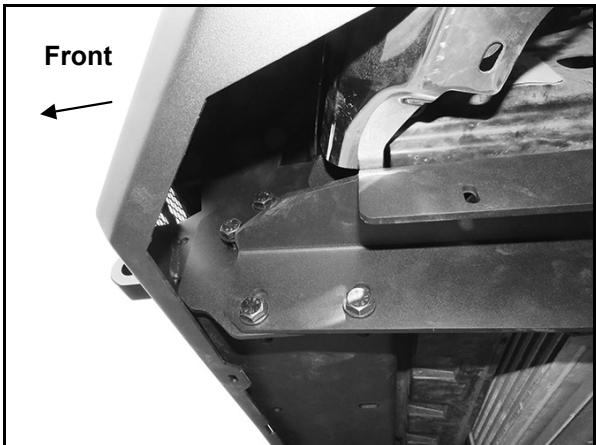

(Fig 21) Attach Bumper to inside of Winch Tray Bracket Assembly (driver/left side pictured without "L" Support Bracket. See Fig 15)

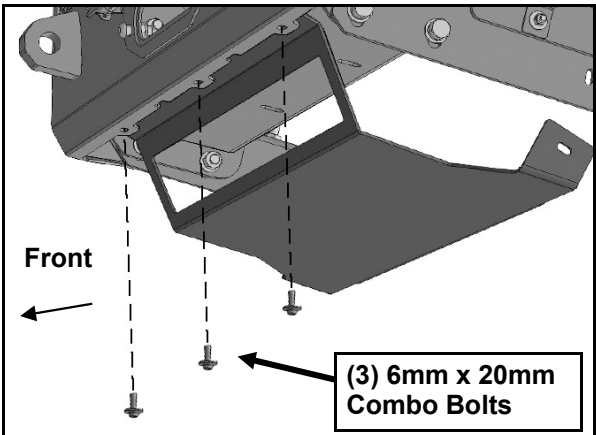

(Fig 22) Attach Air Deflector to inside of Bumper

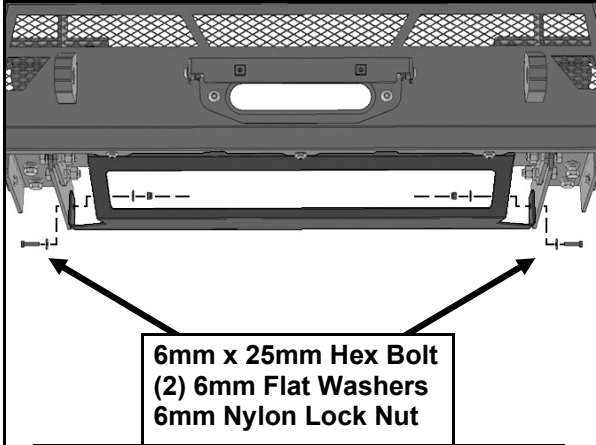

(Fig 23) Attach rear tabs on Air Deflector to inside of Support Brackets

- 8mm x 16mm Hex Bolt
8mm Lock Washer
8mm Flat Washer
- 8mm x 25mm Hex Bolt
(2) 8mm Flat Washers
8mm Lock Washer
8mm Hex Nut

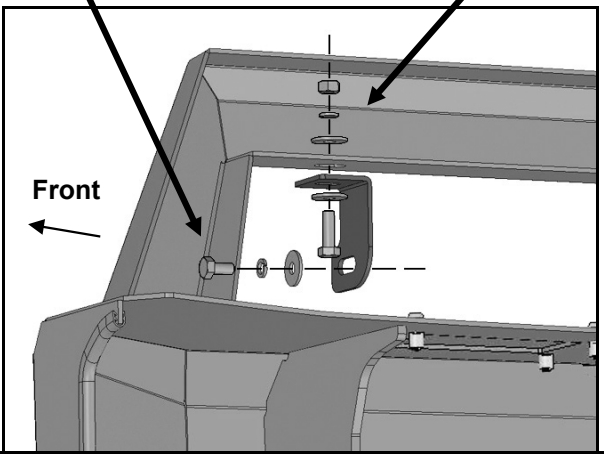

(Fig 24) Attach LED "L" Brackets to bottom of loop. NOTE: Top Light bracket mounting location is designed for 20-24" single or double row bar style light. Flip Brackets side to side if necessary



Discover other off-road bumpers on our website.